

REVISION HISTORY			
REV	DATE	BY	DESCRIPTION
B	19JUN2019	YBS/VK	PRN: P2019-1560

NOTES:  
 1. HANDLE-SHAFT SUB-ASSEMBLY CONSISTS OF:  
 HANDLE: ABS, BLACK (WHEN F=5, FLAT HANDLE ONLY)  
 STEEL, BRIGHT CHROME (WHEN F=1)  
 SHAFT : STEEL, ZINC PLATE PLUS BRIGHT CHROMATE  
 PIN : 18-8 STAINLESS STEEL, PASSIVATE  
 2. CUP: STEEL, POWDER COAT BLACK (WHEN F=5, FLAT HANDLE ONLY)  
 STEEL, BRIGHT CHROME (WHEN F=1)  
 3. PART NUMBER 01-13-35 SHOWN.

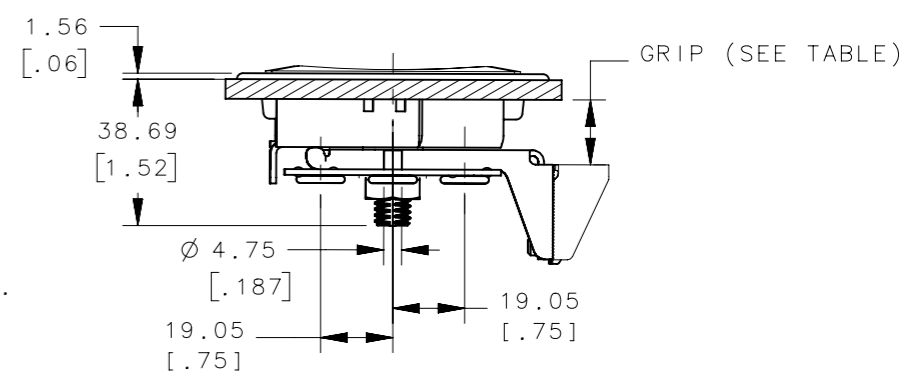

TYPE A INSTALLATION SHOWN  
 FOR TYPE B INSTALLATION:  
 1. ROTATE HOUSING AND PAWL SUB-ASSEMBLY 180°  
 AROUND AXIS OF SHAFT.  
 2. ROTATE HANDLE - SHAFT SUB-ASSEMBLY AND  
 ACTUATOR SUB-ASSEMBLY 90° AROUND AXIS OF SHAFT.

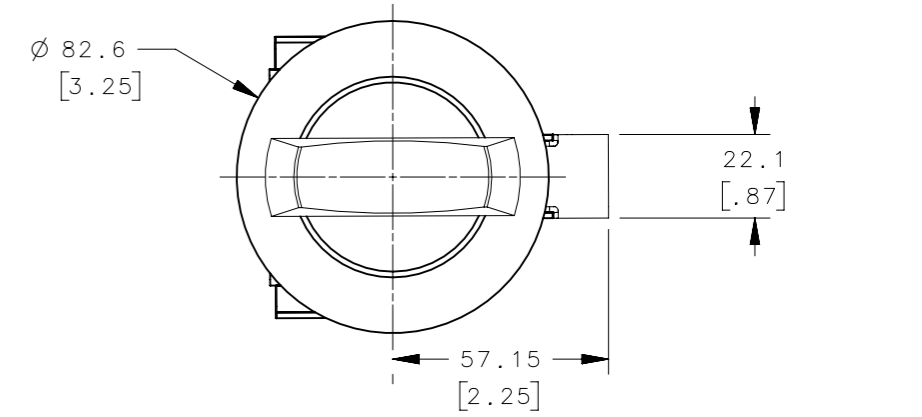
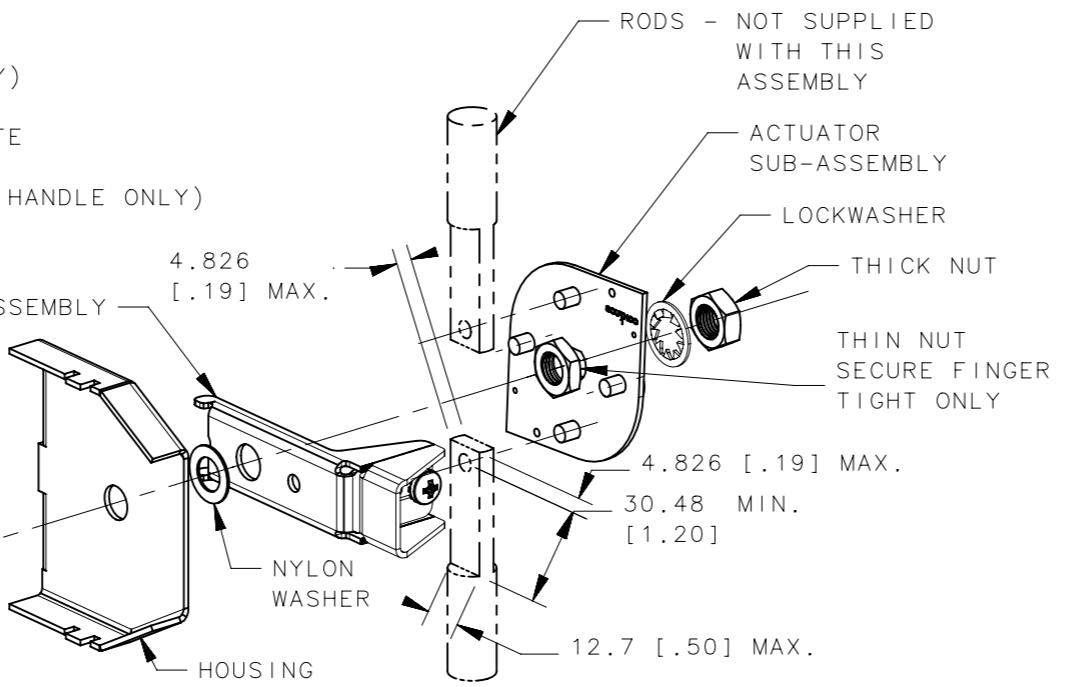
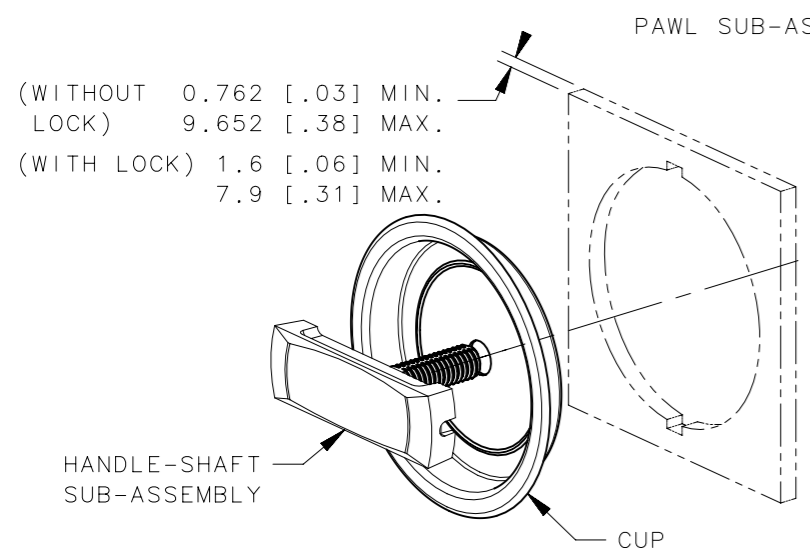
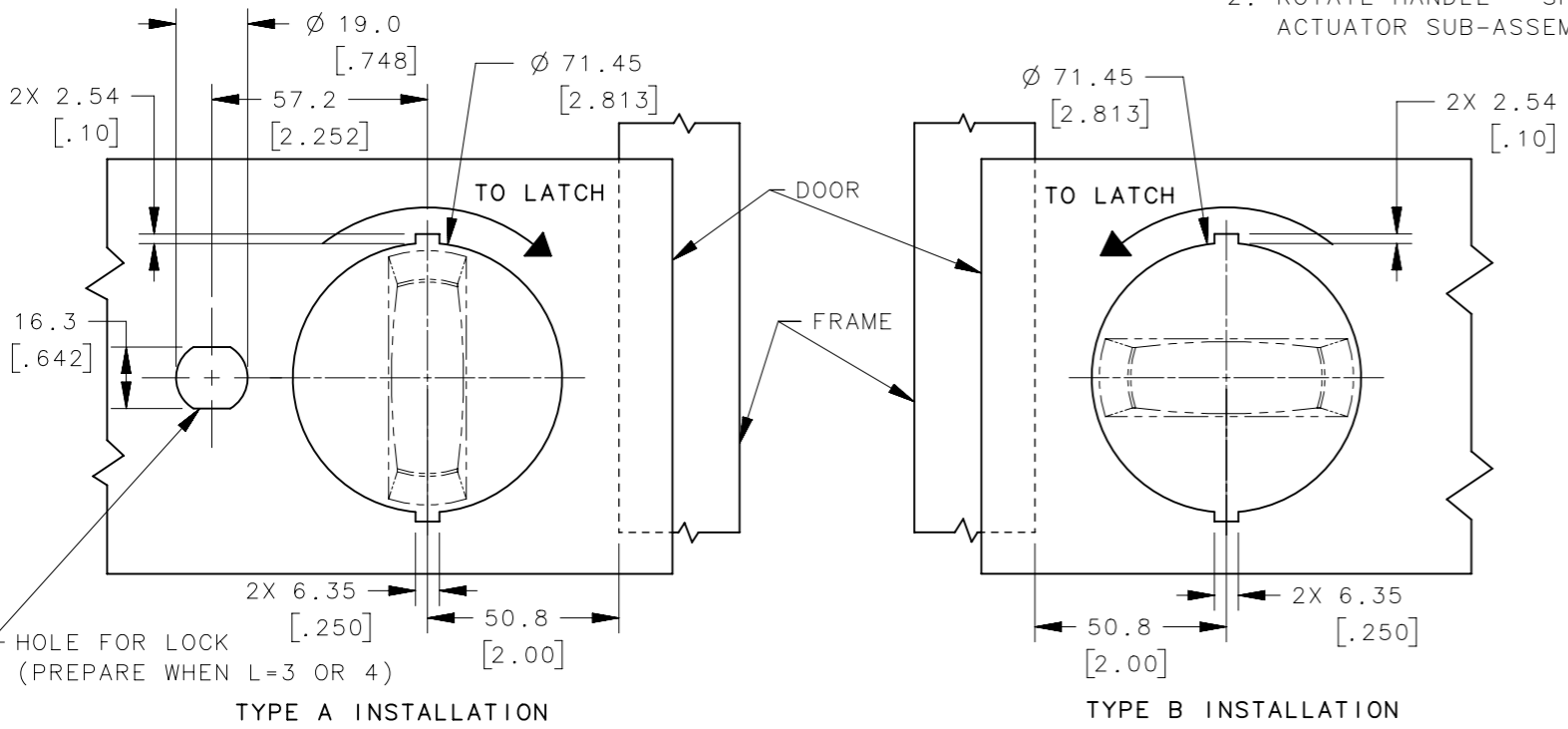

GRIP TABLE

*G* GRIP	GRIP RANGE	TYPE A	TYPE B	CAM TYPE
1	0-12.7	PERPENDICULAR	PARALLEL	SINGLE OR THREE POINT LATCHING
2	0-12.7	PARALLEL	PERPENDICULAR	SINGLE OR THREE POINT LATCHING
3	12.7-28.6	PERPENDICULAR	PARALLEL	SINGLE OR THREE POINT LATCHING
4	12.7-28.6	PARALLEL	PERPENDICULAR	SINGLE OR THREE POINT LATCHING
5	TWO POINT ONLY	PERPENDICULAR	PARALLEL	TWO POINT ONLY
6	TWO POINT ONLY	PARALLEL	PERPENDICULAR	TWO POINT ONLY

NO.	PART NUMBER	TYPE OF COMPONENT	MATERIAL	FINISH
9	-	1	NYLON WASHER	NYLON NATURAL
8	-	1	LOCKWASHER	STEEL ZINC PLATE, BRIGHT CHROMATE
7	-	1	THIN NUT	STEEL ZINC PLATE, BRIGHT CHROMATE
6	-	1	THICK NUT	STEEL ZINC WITH BRIGHT CHROMATE
5	-	1	ACTUATOR, SUB-ASSEMBLY	STEEL ZINC PLATE, BRIGHT CHROMATE
4	-	1	PAWL, SUB-ASSEMBLY	STEEL ZINC WITH BRIGHT CHROMATE
3	-	1	HOUSING	STEEL ZINC PLATE, BRIGHT CHROMATE
2	-	1	CUP	SEE NOTE 2
1	-	1	HANDLE-SHAFT, SUB-ASSEMBLY	SEE NOTE 1
-	01-L3-GF	-	FLUSH CUP LATCH ASSEMBLY	-

PART NUMBER: 01 - L 3 - G F

LOCK STYLE:  
 1- NON-LOCKING FLAT HANDLE  
 2- NON-LOCKING FOLDING BAIL HANDLE  
 3- LOCKING FLAT HANDLE KEYED ALIKE CH751 (TWO KEYS SUPPLIED)  
 4- LOCKING FOLDING BAIL HANDLE KEYED ALIKE CH751 (TWO KEYS SUPPLIED)

FINISH:  
 1- BRIGHT CHROME  
 5- BLACK (FLAT HANDLE ONLY)

GRIP:  
 (SEE GRIP TABLE)

THIRD ANGLE PROJECTION

MILLIMETERS [IN]

TOLERANCES UNLESS OTHERWISE NOTED

ALL DIMENSIONS WITHOUT TOLERANCES ARE FOR REFERENCE ONLY.

PER ASME Y14.5M-1994

PROPRIETARY ITEM EXCEPT FOR USES EXPRESSLY GRANTED IN WRITING, INFORMATION DISCLOSED HEREON IS CONFIDENTIAL AND ALL RIGHTS, PATENT AND OTHERWISE, ARE RESERVED BY SOUTHCO, INC.

**southco**  
 CONNECT • CREATE • INNOVATE

DESCRIPTION: FLUSH CUP LATCH

SIZE: A3 SYSTEM: NX DWG NO.: J-01-3

DRAWN BY: NBK/DMS DATE: 07DEC2017 SCALE: 1:2 SHEET: 1 OF 1