

PART NUMBER	A	B	C	D
09-13-102-XX	.100	.297	.422	.734
09-13-103-XX	.150			
09-13-202-XX	.100			
09-13-203-XX	.150	.422	.547	.859
09-13-204-XX	.200			
09-13-205-XX	.250			
09-13-302-XX	.100			
09-13-303-XX	.150	.547	.672	.984
09-13-304-XX	.200			
09-13-305-XX	.250			
09-13-307-XX	.350			
09-13-402-XX	.100			
09-13-403-XX	.150			
09-13-404-XX	.200	.672	.797	1.109
09-13-405-XX	.250			
09-13-407-XX	.350			
09-13-409-XX	.450			
09-13-502-XX	.100			
09-13-503-XX	.150			
09-13-504-XX	.200	.797	.922	1.234
09-13-505-XX	.250			
09-13-507-XX	.350			
09-13-509-XX	.450			
09-13-511-XX	.550			
09-13-602-XX	.100			
09-13-603-XX	.150			
09-13-604-XX	.200			
09-13-605-XX	.250	.922	1.047	1.359
09-13-607-XX	.350			
09-13-609-XX	.450			
09-13-611-XX	.550			
09-13-613-XX	.650			
09-13-615-XX	.750			
09-13-702-XX	.100			
09-13-703-XX	.150			
09-13-704-XX	.200			
09-13-705-XX	.250			
09-13-707-XX	.350	1.047	1.172	1.484
09-13-709-XX	.450			
09-13-711-XX	.550			
09-13-713-XX	.650			
09-13-715-XX	.750			
09-13-717-XX	.850			
09-13-802-XX	.100			
09-13-803-XX	.150			
09-13-804-XX	.200			
09-13-805-XX	.250			
09-13-807-XX	.350			
09-13-809-XX	.450	1.172	1.297	1.609
09-13-811-XX	.550			
09-13-813-XX	.650			
09-13-815-XX	.750			
09-13-817-XX	.850			
09-13-819-XX	.950			

REVISION HISTORY			
REV	DATE	BY	DESCRIPTION
A	13MAR2020	MBT/DMS	PRN : P2020-0490

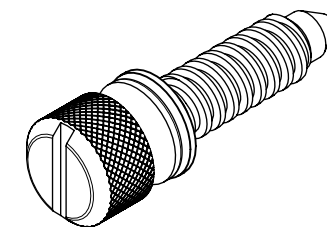

SCALE 2:1

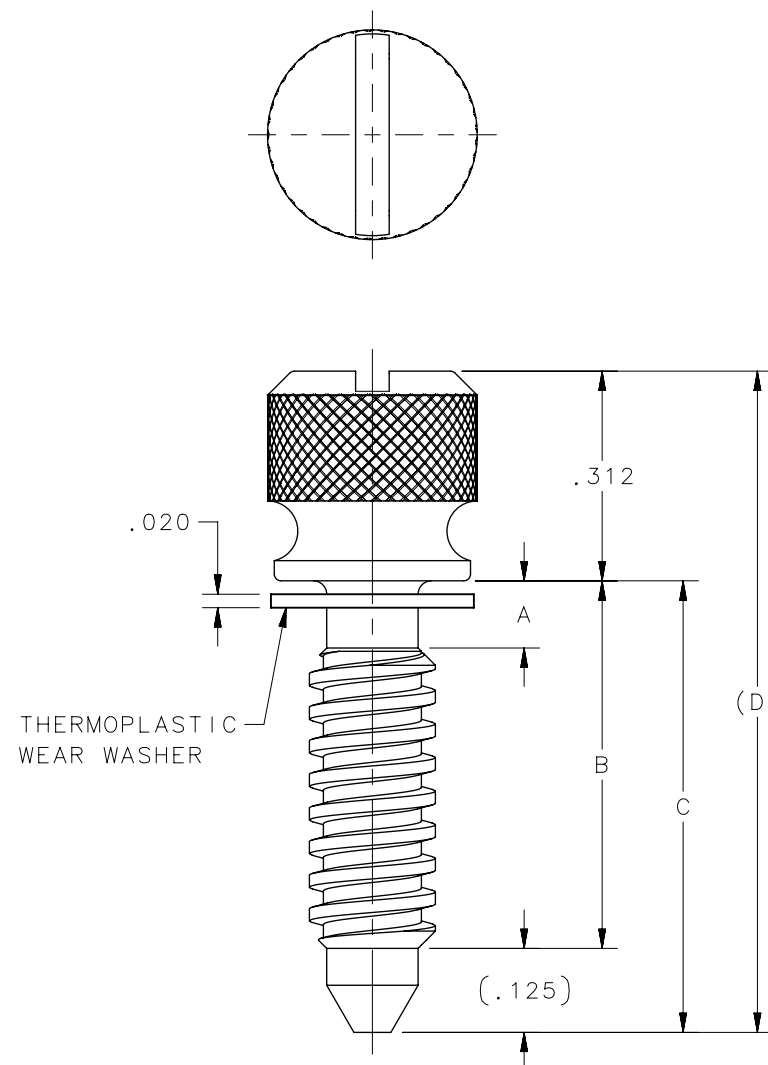

PART SHOWN: 09-13-302-11.

NOTES:
A. FOR SCREWS WITHOUT WEAR WASHER,
CHANGE FIRST DIGIT OF SECOND UNIT
OF PART NUMBER TO "2"
EXAMPLE : 09-13-102-XX WITH WASHER
09-23-102-XX WITHOUT WASHER

09-13-XXX-26	SCREW	STAINLESS STEEL	PASSIVATE
09-13-XXX-14	SCREW	STEEL	CHROME PLATE
09-13-XXX-11	SCREW	STEEL	ZINC PLATE
SOUTHCO PART NUMBER	TYPE OF COMPONENT	MATERIAL	FINISH

THIRD ANGLE PROJECTION		 CONNECT • CREATE • INNOVATE	
INCHES [MM]			
SURFACE AREA .947mm ²		DESCRIPTION SOUTHCO No. 09 FASTENER ASSEMBLIES KNURLED HEAD SCREWS	
VOLUME .032mm ³			
PROPRIETARY ITEM		SIZE B	SYSTEM NX
EXCEPT FOR USES EXPRESSLY GRANTED IN WRITING, INFORMATION DISCLOSED HEREON IS CONFIDENTIAL AND ALL RIGHTS, PATENT AND OTHERWISE, ARE RESERVED BY SOUTHCO, INC.		DWG NO. J-09-13	
PER ASME Y14.5M-1994		DRAWN BY MBT/DMS	DATE 13MAR2020
		SCALE 3.5:1	SHEET 1 OF 1