

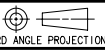

REV	DATE	DRAWN/CHKD	DESCRIPTION	PART NUMBER	SCREW PROJECTION		PANEL THICKNESS		B	L	INCHES
					P-1	P-2	A, MIN	A, MAX			
A	11OCT2007	GDW	PRN: P2007-1268	47-10-2X0-YZ	.09	.28	-	.031	.083	.113	ALL DIMENSIONS WITHOUT TOLERANCES ARE FOR REFERENCE ONLY.
				47-11-2X0-YZ	.16	.35					
				47-12-2X0-YZ	.22	.41					
				47-10-2X1-YZ	.09	.28					
				47-11-2X1-YZ	.16	.35	.031	.063	.114	.144	
				47-12-2X1-YZ	.22	.41					
				47-10-2X2-YZ	.16	.35	.063	.094	.146	.176	
				47-11-2X2-YZ	.22	.41					
				47-10-2X3-YZ	.16	.35	.094	.126	.177	.207	
				47-11-2X3-YZ	.22	.41					
				47-10-2X4-YZ	.22	.41	.126	.157	.209	.238	
				47-10-2X5-YZ	.22	.41	.157	.189	.240	.269	

INCHES

 THIRD ANGLE PROJECTION

 B PAPER SIZE

MATERIAL AND FINISH:
 KNOB: 6000 SERIES ALUMINUM, NATURAL OR BLACK POWDER COATED
 SCREW: 400 SERIES STAINLESS STEEL, PASSIVATED; OR HARDENED CARBON STEEL, ZINC PLATE, CHROMATE PLUS SEALER (SEE "Z" TABLE) (NOTE: KNOB AND TOP OF SCREW AVAILABLE WITH POWDER COATING; SEE "Y" TABLE)
 FERRULE: 6000 SERIES ALUMINUM, NATURAL
 SPRING: 300 SERIES STAINLESS STEEL, PASSIVATED
 WASHER: 300 SERIES STAINLESS STEEL, PASSIVATED

"Z" KNOB TYPE AND SCREW MATERIAL

KNOB	SCREW MATERIAL	RECESS	
		SLOTTED TORX [®] PHILLIPS/SLOT	TORX [®] /SLOT
KNURLED	STAINLESS STEEL	0	N/A
SMOOTH	STAINLESS STEEL	1	N/A
KNURLED	STEEL	4	0
SMOOTH	STEEL	5	1

- "X" SCREW RECESS
- 1 - SLOTTED
 - 3 - No. 2 PHILLIPS
 - 5 - T15 TORX
 - 7 - T15 TORX[®]/SLOT COMBINATION
 - 9 - No. 2 PHILLIPS/SLOT COMBINATION

- "Y" FINISH ON KNOB & SCREW HEAD
- 1 - BRIGHT
 - 4 - CUSTOM COLOR. SEE J-47-0-3 FOR ADDITIONAL SUFFIX
 - 5 - BLACK POWDER COATED

KNURLED KNOBS



SMOOTH KNOBS

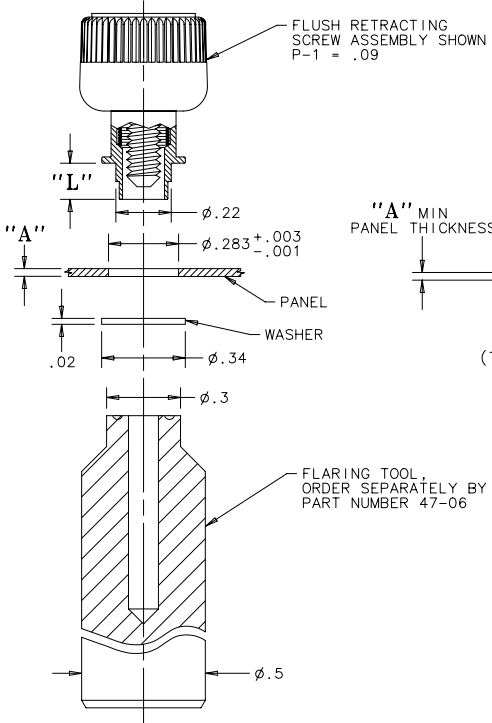
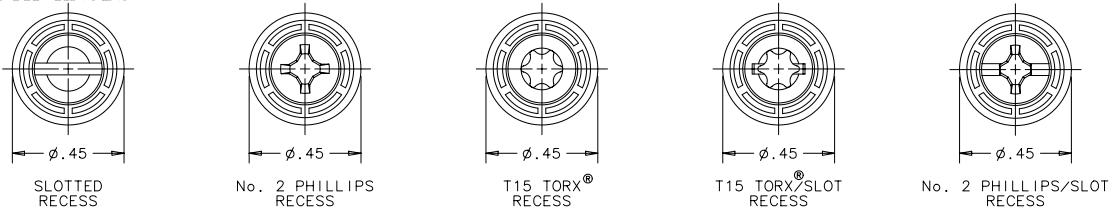

PANEL PREPARATION
 PART NUMBER: 47-10-2X1-YO SHOWN

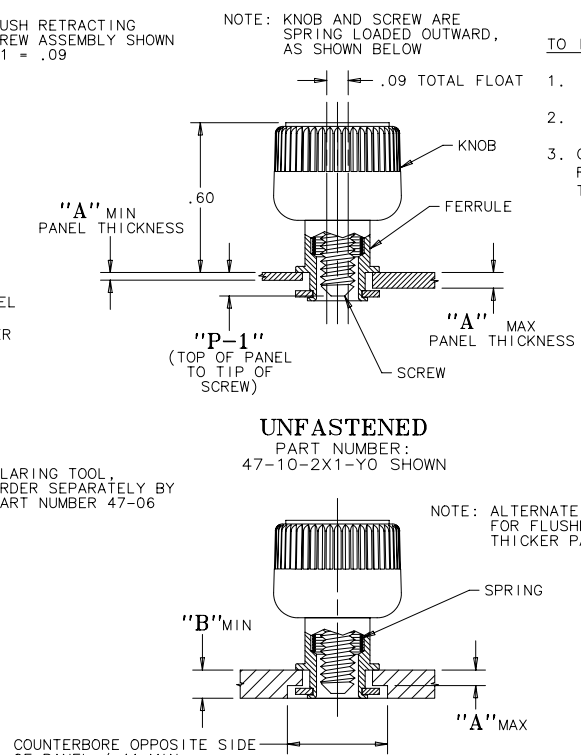

UNFASTENED
 PART NUMBER: 47-10-2X1-YO SHOWN

TO INSTALL FASTENER:

1. DRILL OR PUNCH HOLE AS SHOWN BELOW.
2. PLACE FERRULE INTO INSTALLATION HOLE.
3. CENTER TOOL ON THE SCREW THREAD, THEN ROLL FERRULE OVER WASHER TO CAPTIVATE THE ASSEMBLY.

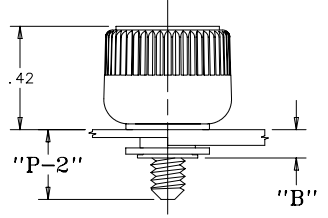

FASTENED
 PART NUMBER: 47-10-2X1-YO SHOWN

NOTE: ALTERNATE INSTALLATION FOR FLUSHNESS AND/OR THICKER PANELS

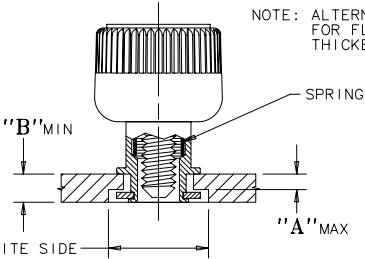

TORX[®] IS A REGISTERED TRADEMARK OF THE CAMCAR DIVISION OF TEXTRON, INC.

DRAWING NUMBER
 J-47-2-632