

**southco**

PROPRIETARY ITEM - EXCEPT FOR USES EXPRESSLY GRANTED IN WRITING INFORMATION DISCLOSED HEREON IS CONFIDENTIAL AND ALL RIGHTS PATENT AND OTHERWISE ARE RESERVED BY SOUTHCO, INC.

**SOUTHCO No. 47 CAPTIVE FASTENER  
M3 THREAD, PRESS-IN STYLE**

DATE: 06JUL2002  
DRAWN: DLH  
CHKD:  
SCALE: 2:1

DRAWING NUMBER:  
**J-47-3-M3**

REV	DATE	DRAWN/CHKD	DESCRIPTION	PART NUMBER
A	13FEB2004	DLH/AJH	PRN: P2004-0148	
B	08MAR2004	DLH/AJH	PRN: P2004-0246	47-90-1X1-YZ
C	30OCT2006	AJH/MDY	PRN: P2006-1511	47-91-1X1-YZ
D	10AUG2007	VSR/VSU	PRN: P2007-1042	47-92-1X1-YZ
				47-93-1X1-YZ

SCREW PROJECTION	PANEL THICKNESS	
	A, MIN	A, MAX
P-1		
P-2		
	0.8	3.8
	2.5	5.5
	4.0	7.0
	5.6	8.8

**MILLIMETERS**

ALL DIMENSIONS WITHOUT TOLERANCES ARE FOR REFERENCE ONLY.

THIRD ANGLE PROJECTION

A3 PAPER SIZE

NOTES:  
A. RoHS COMPLAINT.

**MATERIAL AND FINISH:**

KNOB: 6000 SERIES ALUMINUM

SCREW: 400 SERIES STAINLESS STEEL, PASSIVATED; OR HARDENED CARBON STEEL, ZINC PLATE, CHROMATE PLUS SEALER (SEE "Z" TABLE) (NOTE: KNOB AND TOP OF SCREW AVAILABLE WITH POWDER COATING; SEE "Y" TABLE)

FERRULE: HEAT TREATED STEEL; ZINC PLATE, CHROMATE PLUS SEALER

SPRING: 300 SERIES STAINLESS STEEL, PASSIVATED

**"X" SCREW RECESS**

- 0 - SLOTTED
- 2 - No. 1 PHILLIPS
- 4 - T10 TORX
- 6 - T10 TORX/SLOT COMBINATION
- 8 - No. 1 PHILLIPS/SLOT COMBINATION

**"Y" FINISH ON KNOB & SCREW HEAD**

- 2 - BRIGHT
- 4 - CUSTOM COLOR. SEE J-47-0-3 FOR ADDITIONAL SUFFIX
- 6 - BLACK POWDER COATED

**"Z" KNOB TYPE AND SCREW MATERIAL**

KNOB	SCREW MATERIAL	RECESS	
		SLOTTED TORX PHILLIPS/SLOT	TORX/SLOT
KNURLED	STAINLESS STEEL	0	N/A
SMOOTH	STAINLESS STEEL	1	N/A
KNURLED	STEEL	4	0
SMOOTH	STEEL	5	1

**KNURLED KNOBS**

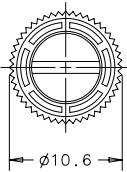

SLOTTED RECESS

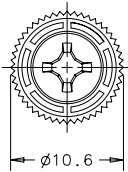

No. 1 PHILLIPS RECESS

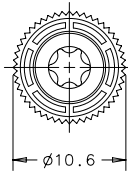

T10 TORX RECESS

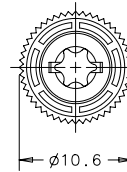

T10 TORX/SLOT RECESS

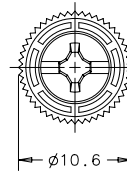

No. 1 PHILLIPS/SLOT RECESS

**SMOOTH KNOBS**

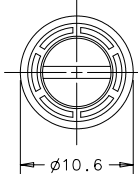

SLOTTED RECESS

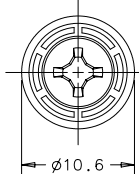

No. 1 PHILLIPS RECESS

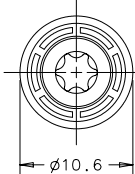

T10 TORX RECESS

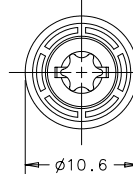

T10 TORX/SLOT RECESS

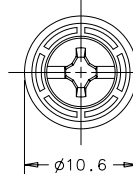

No. 1 PHILLIPS/SLOT RECESS

FLUSH RETRACTING SCREW ASSEMBLY SHOWN  
P-1 = 0.8

NOTE: KNOB AND SCREW ARE SPRING LOADED OUTWARD, AS SHOWN BELOW

**TO INSTALL FASTENER:**

1. DRILL OR PUNCH HOLE AS SHOWN BELOW.
2. PLACE FERRULE INTO INSTALLATION HOLE.
3. PROVIDE SOLID BACK-UP BEHIND HOLE WITH CLEARANCE HOLE  $\phi 3.2^{+0.1}$  FOR SCREW.
4. PRESS PART INTO PANEL UNTIL RECOMMENDED LOAD IS APPLIED.

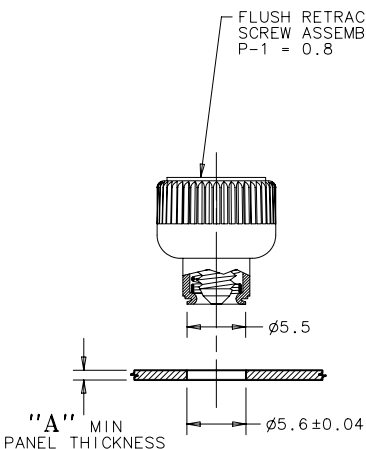

**PANEL PREPARATION**  
PART NUMBER:  
47-90-1X1-Y0 SHOWN

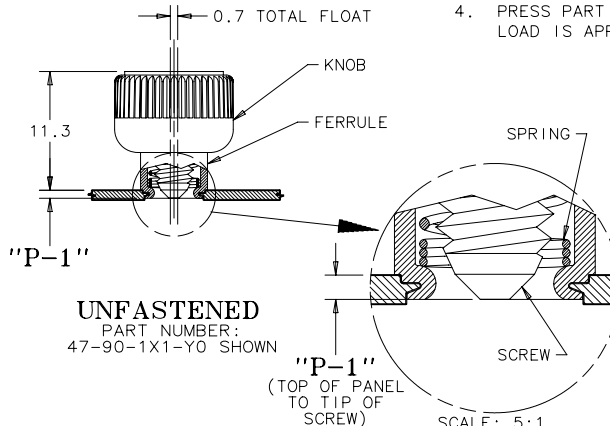

**UNFASTENED**  
PART NUMBER:  
47-90-1X1-Y0 SHOWN

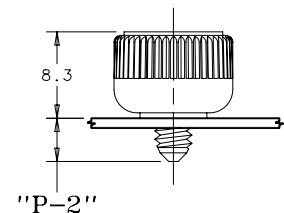

**FASTENED**  
PART NUMBER:  
47-90-1X1-Y0 SHOWN

SCALE: 5:1