

**southco®**

PROPRIETARY ITEM - EXCEPT FOR USES EXPRESSLY GRANTED IN WRITING INFORMATION DISCLOSED HEREON IS CONFIDENTIAL AND ALL RIGHTS PATENT AND OTHERWISE ARE RESERVED BY SOUTHCO, INC.

No. 56 SPRING LOADED PLUNGER ASSEMBLY, PRESS-IN STYLE WITH SMALL OVERMOLDED KNOB AND WITHOUT STAY-OPEN FEATURE

DATE: 05APR2003  
 DRAWN: DLH  
 CHKD: AJH  
 SCALE: 2:1

DRAWING NUMBER: J-56-160

REV	DATE	DRAWN/CHKD	DESCRIPTION	PART NUMBER	KNOB COLOR
A	10APR2003	VNI/MJS	PRN: P2003-0283	56-160-EEE	SEE NOTE G
B	08MAY2003	DLH/VNI	PRN: P2003-0348		
C	28MAY2003	DLH/AJH	PRN: P2003-0423		
D	24JUN2003	AJH/MJS	PRN: P2003-0532		
E	23JUL2003	DLH/AJH	PRN: P2003-0611		
F	22DEC2004	VNI/AJH	PRN: P2004-1471		
G	06JUN2012	CMS/CDW	PRN: P2012-0742		

**INCHES**

ALL DIMENSIONS WITHOUT TOLERANCES ARE FOR REFERENCE ONLY.

THIRD ANGLE PROJECTION

A PAPER SIZE

**NOTES:**

- A. INSTALLATION INSTRUCTIONS:
  1. DRILL OR PUNCH INSTALLATION HOLE.
  2. PLACE FERRULE INTO INSTALLATION HOLE.
  3. PROVIDE SOLID BACK-UP BEHIND HOLE WITH CLEARANCE HOLE FOR STUD.
  4. PRESS ON HEAD OF KNOB/STUD SUBASSEMBLY UNTIL SHOULDER OF FERRULE IS FIRMLY AGAINST OUTER PANEL.
  5. PUNCH CANNOT TOUCH PLASTIC DURING INSTALLATION.
- B. MATERIAL AND FINISH:
  - FERRULE AND ENDCAP: STEEL, ZINC PLATE PLUS SEALER
  - SPRING: STAINLESS STEEL, NATURAL
  - STUD: HARDENED STEEL, ZINC PLATE PLUS SEALER
  - KNOB: PC/ABS, BLACK
- C. GATE NOT ORIENTED WITH FRAME BREAK.
- D. FLASH HEIGHT GREATER THAN .012 NOT ACCEPTABLE.
- E. SURFACE IMPERFECTIONS: INSPECT PARTS FROM 2 FEET FOR 3 SECONDS. FOUR SURFACE IMPERFECTIONS MAX PER PART ALLOWED. SURFACE IMPERFECTIONS TO BE NO LARGER THAN .045 IN DIAMETER, HEIGHT, OR WIDTH.
- F. PARTS SHIPPED BULK
- G. PART NUMBER SUFFIX "EEE" = KNOB COLOR:  
 -000 = BLACK  
 (FOR ADDITIONAL COLORS SEE DWG J-47-0-3)

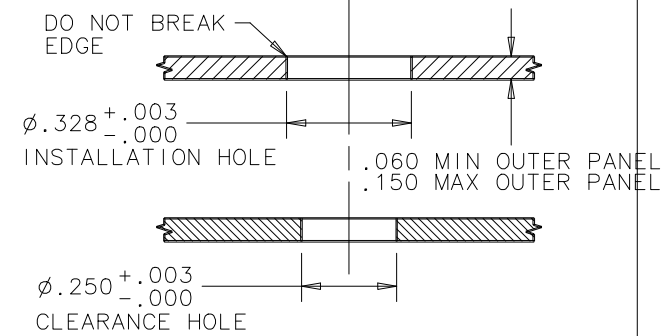
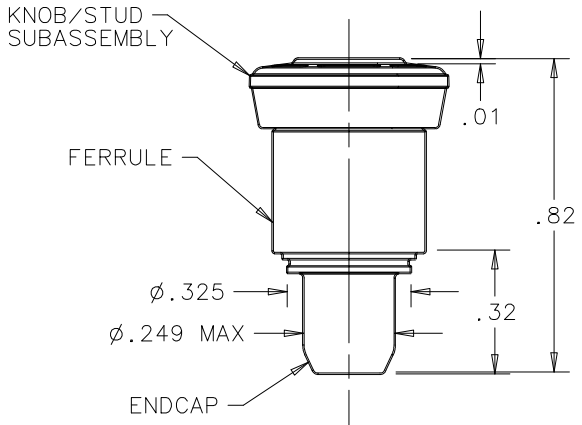
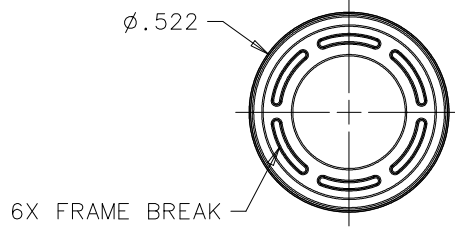
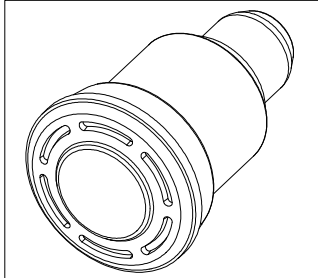

**PANEL PREPARATION**

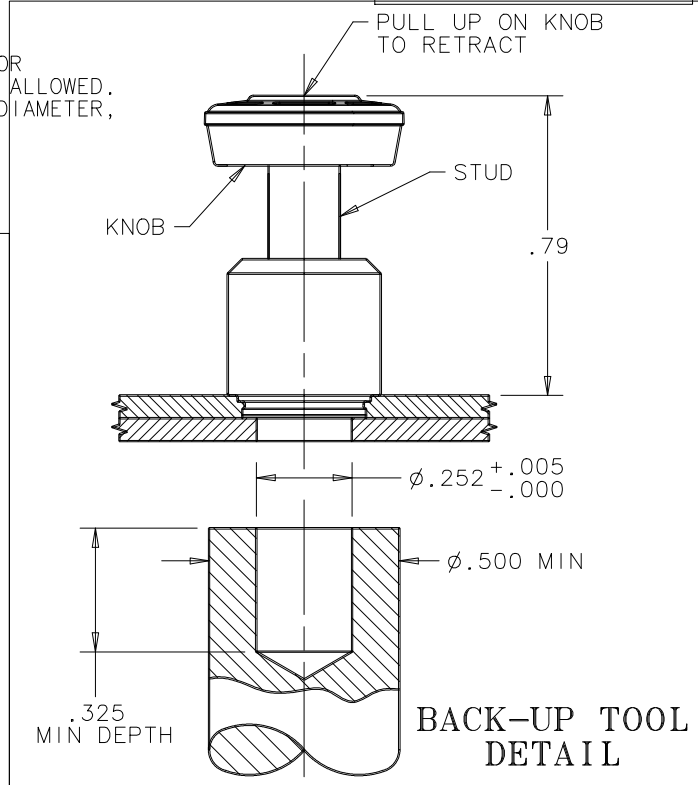
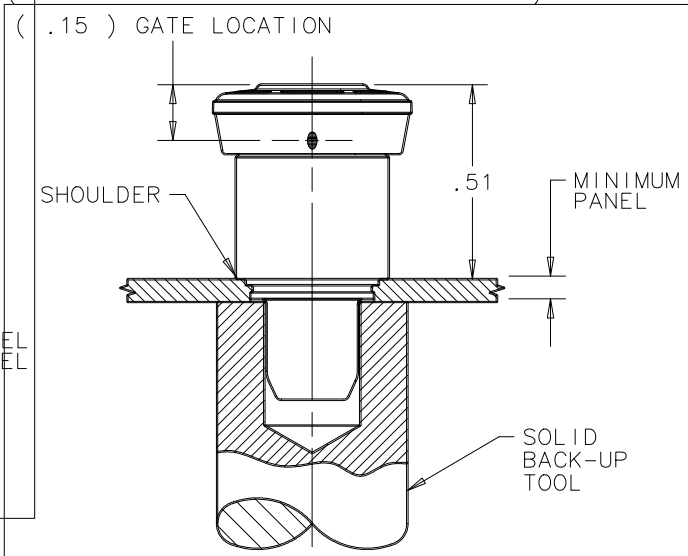

**BACK-UP TOOL DETAIL**