

REVISION HISTORY			
REV	DATE	BY	DESCRIPTION
C	19APR2019	JQ/LC	PRN: P2019-1029



SCALE 1:1

NOTES:

A. INSTALLATION INSTRUCTIONS:

1. DRILL OR PUNCH $\varnothing 9.12 \pm 0.08$ HOLE IN OUTER PANEL.
2. PRESS STUD FIRMLY TO HOLD TEETH OF FERRULE AGAINST PANEL. THREAD SLEEVE NUT INTO FERRULE AND TIGHTEN WITH WRENCH SOUTHCO PART NUMBER 56-0-22041-04.

B. MATERIAL AND FINISH:

1. STUD: HARDENED STEEL, ZINC PLATE PLUS SEALER.
2. SPRING: 300 SERIES SATINLESS STEEL, PASSIVATED.
3. END CAP, FERRULE AND SLEEVE NUT: STEEL, ZINC PLATED PLUS SEALER.

C. COSMETIC SPECIFICATION: ALL SURFACES (UNLESS OTHERWISE SPECIFIED) ARE TO BE PER SOUTHCO SPECIFICATION S-121-02, CLASS B, FERRULE AND SLEEVE NUT CLASS C.

D. PARTS SHIPPED BULK.

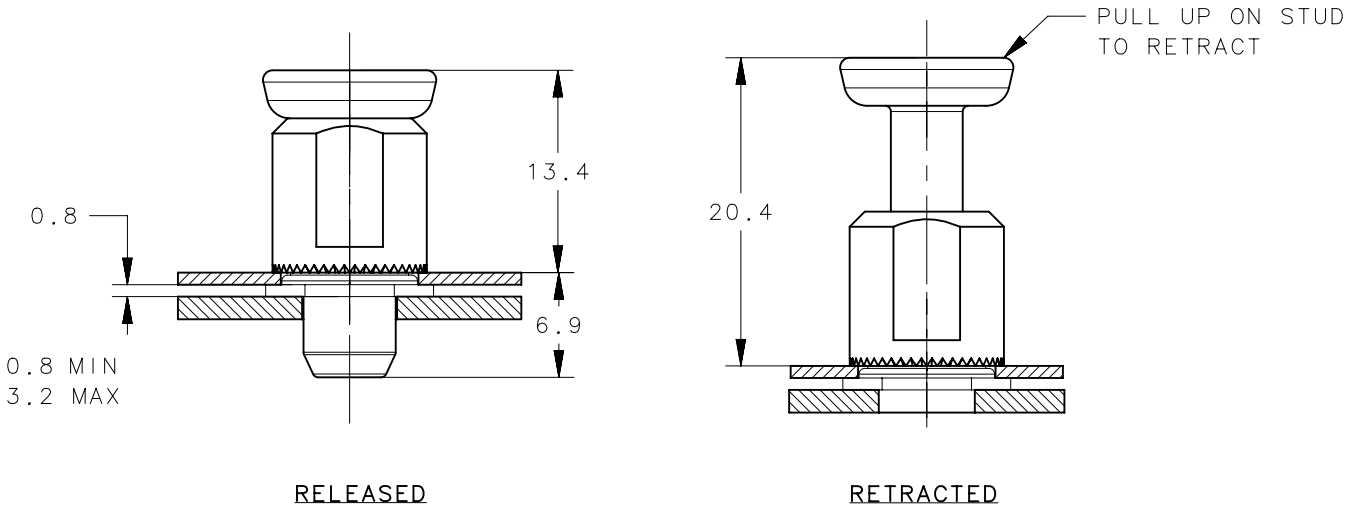
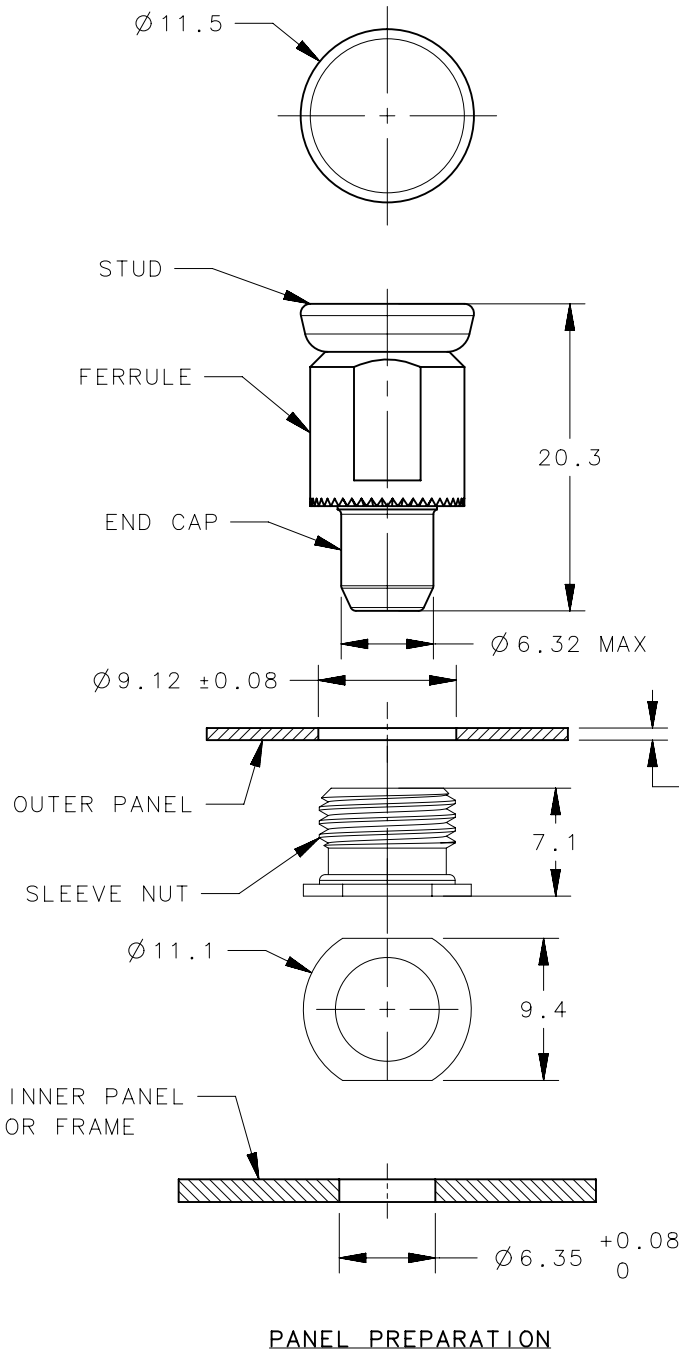

56-80-15	N/A	SEE NOTES	SEE NOTES
PART NUMBER	TYPE OF COMPONENT	MATERIAL	FINISH

	THIRD ANGLE PROJECTION	
	MILLIMETERS [IN]	
SURFACE AREA	TOLERANCES UNLESS OTHERWISE NOTED	
VOLUME	UP TO 0.5 ±0.1	
	OVER 0.5 UP TO 6 ±0.2	
	OVER 6 UP TO 30 ±0.4	
	OVER 30 ±0.6	
	ANGLES ±5°	
PROPRIETARY ITEM	PER ASME Y14.5M-1994	
EXCEPT FOR USES EXPRESSLY GRANTED IN WRITING, INFORMATION DISCLOSED HEREON IS CONFIDENTIAL AND ALL RIGHTS, PATENT AND OTHERWISE, ARE RESERVED BY SOUTHCO, INC.		

 CONNECT • CREATE • INNOVATE		DESCRIPTION	
		56 PLUNGER THREAD-IN, BRIGHT-SMALL	
SIZE	SYSTEM	DWG NO.	
A4	NX	J-56-80-15	
DRAWN BY	DATE	SCALE	SHEET
JQ/LC	29MAR2018	2:1	1 OF 1