



SOUTHCO No.85
"U" TYPE CLIP-ON RECEPTACLE

DATE	DRAWN	CHKD	SCALE	DRAWING NUMBER
6-3-68	J.G.K.	ESK	N.T.S.	J-85-55

REV. LET.	DATE	BY-CHKD	REVISIONS	PART No.	MATERIAL	FINISH
E	10AUG93	JGK	REDRAWN FOR CLARITY, SEE RECORD PRINT.	85-47-101-20	STAINLESS STEEL	PASSIVATED
				85-47-101-58	" "	NOTE "A"

NOTE "A": PASSIVATED PLUS BLACK ORGANIC COATING.

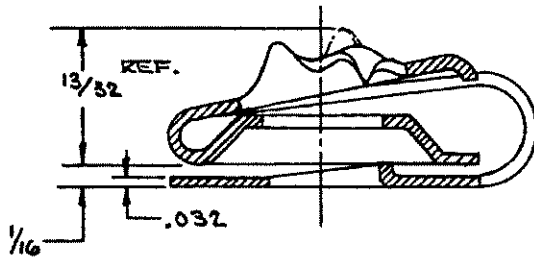
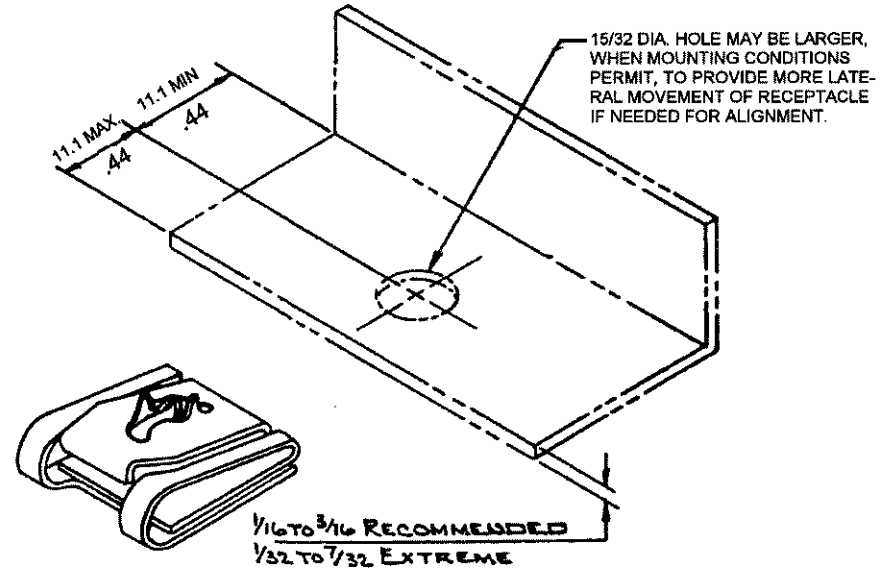
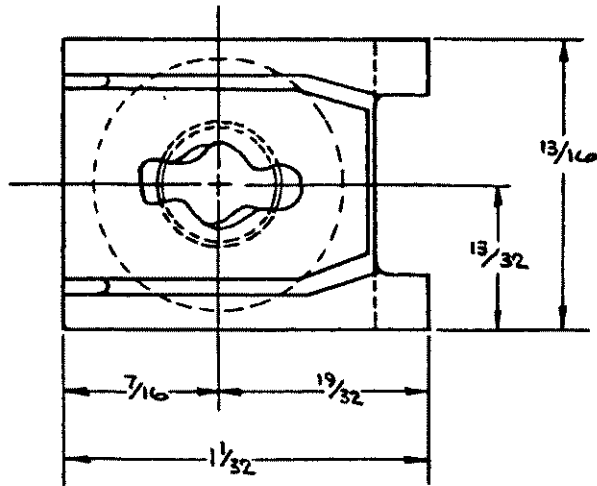

TO SELECT PROPER STUD LENGTH

TYPE "A" APPLICATION

TO SELECT PROPER STUD FOR APPLICATIONS OF THIS TYPE, ADD THICKNESS OF OUTER PANEL TO THICKNESS OF INNER PANEL, PLUS A CONSTANT OF .037 THE TOTAL EQUALS THE GRIP OF STUD REQUIRED.

TYPE "B" APPLICATION

IF SPACE IS LESS THAN .052 USE STUD SELECTION FOR TYPE "A" APPLICATION

TO SELECT PROPER STUD FOR APPLICATIONS OF THIS TYPE, ADD THICKNESS OF OUTER PANEL TO THICKNESS OF INNER PANEL, MINUS A CONSTANT OF .015. TOTAL EQUALS THE GRIP OF THE STUD REQUIRED.