

REV.	DATE	BY-CHKD	REVISIONS
A	30MAY1996	BMC	PRN: 92-112
B	05AUG1996	BMC	PRN: 92-115
C	20JUL2000	JPW	PRN: 93-238A

HANDLE STYLE	L	GRIP RANGE		ASSEMBLY PART NUMBERS SHORT PAWL		ASSEMBLY PART NUMBERS LONG PAWL	
		MIN.	MAX.	TYPE *A*	TYPE *B*	TYPE *A*	TYPE *B*
BRIGHT CHROME PLATED							
WITH LOCK	32	16	19	92-21-111	92-22-111	92-21-112	92-22-112
	44.5	16	32	92-21-121	92-22-121	92-21-122	92-22-122
	57.5	16	44.5	92-21-131	92-22-131	92-21-132	92-22-132
WITHOUT LOCK	32	16	19	92-11-111	92-12-111	92-11-112	92-12-112
	44.5	16	32	92-11-121	92-12-121	92-11-122	92-12-122
	57.5	16	44.5	92-11-131	92-12-131	92-11-132	92-12-132
BLACK POWDER COATED							
WITH LOCK	32	16	19	92-21-511	92-22-511	92-21-512	92-22-512
	44.5	16	32	92-21-521	92-22-521	92-21-522	92-22-522
	57.5	16	44.5	92-21-531	92-22-531	92-21-532	92-22-532
WITHOUT LOCK	32	16	19	92-11-511	92-12-511	92-11-512	92-12-512
	44.5	16	32	92-11-521	92-12-521	92-11-522	92-12-522
	57.5	16	44.5	92-11-531	92-12-531	92-11-532	92-12-532

MATERIAL AND FINISH
 HANDLE & ESCUTCHEON: DIE CAST ZINC, BRIGHT CHROME PLATED OR BLACK POWDER COATED.

SHAFT, NUTS, MOUNTING SCREWS, RETAINER PLATE, PAWL: LOW CARBON STEEL, ZINC ALLOY PLATE, BRIGHT CHROMATE PLUS SEALER.

LOCKWASHERS: SPRING STEEL, ZINC ALLOY PLATE, BRIGHT CHROMATE PLUS SEALER.

GASKET: SBR RUBBER WITH FIBER, NATURAL.

SPRING WASHER: 300 STAINLESS STEEL, ZINC PLATE PLUS BRIGHT CHROMATE.

O-RING: BUNA-N RUBBER, NATURAL.

PIN: 1008 STEEL, ZINC PLATED PLUS YELLOW CHROMATE.

LOCKSLIDE: DIE CAST ZINC WITH CHEMICAL PROTECTIVE FILM.

LOCKPLUG: DIE CAST ZINC, BRIGHT STAINLESS STEEL SCALP OR BLACK POWDER COATED ON HEAD, KEYED ALIKE TO CH751.

KEYS: BRASS, NICKEL PLATED.

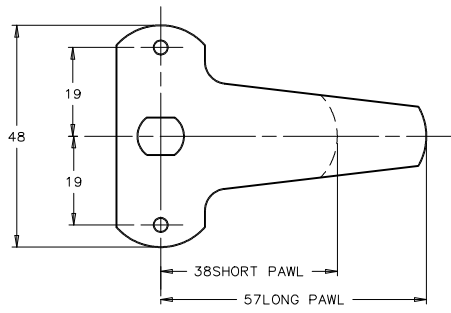

PAWL SUB-ASSEMBLY

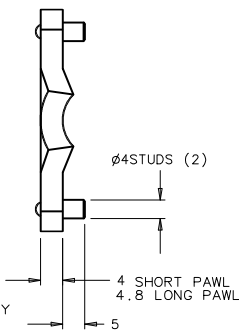

RETAINER PLATE

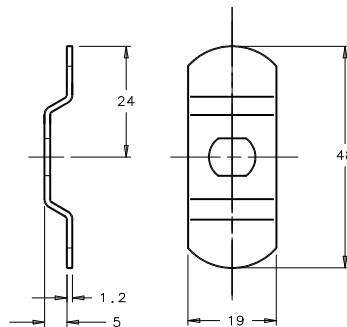

PANEL PREPARATION

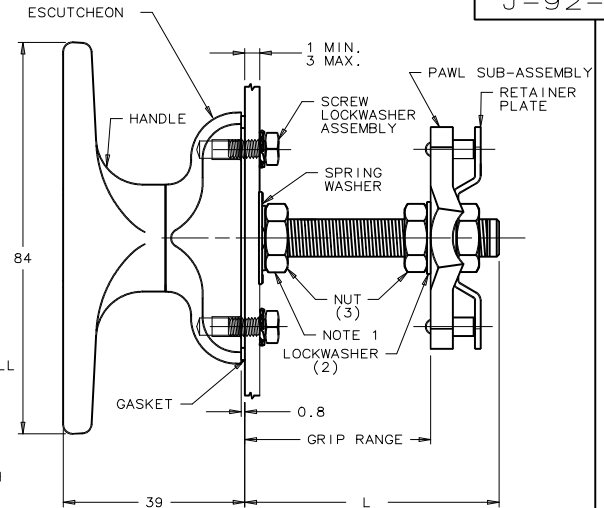
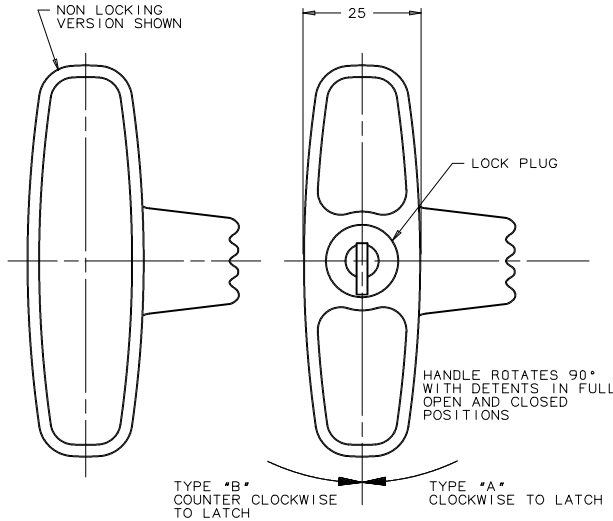

NOTE 1: DO NOT ALTER THIS FACTORY PRE-SET NUT.

INSTALLATION

1. PREPARE PANEL AS SHOWN
2. ASSEMBLE HARDWARE AS SHOWN
3. MOVE PAWL ASSEMBLY TO DESIRED GRIP POSITION AND TIGHTEN NUTS AGAINST PAWL ASSEMBLY WITH TWO WRENCHES.
4. FOR THREE-POINT LATCHING, INSTALL RODS ON STUDS BEFORE TIGHTENING NUTS.

 DRAWING NUMBER
J-92-1

ALL DIMENSIONS ARE IN MILLIMETERS
 ALL DIMENSIONS IN INCHES ARE BY REFERENCE.
 THIRD ANGLE PROJECTION DRAWING.