

COMPONENT MATERIAL AND FINISH TABLE		
COMPONENTS	MATERIAL	FINISH
WAFERS	BRASS	NATURAL
LOCK PLUG	DIE CAST ZINC	CHROMATE DIP
LOCK SLIDE	DIE CAST ZINC	NATURAL
ROLL PIN	SPRING STEEL	NICKEL PLATED
RETAINING RING	DIE CAST ZINC	N/A
SHAFT	LOW CARBON STEEL	NICKEL PLATED
ESCUTCHEON	DIE CAST ZINC	CHROME PLATE OR BLACK POWDER COATING
HANDLE	DIE CAST ZINC	CHROME PLATE OR BLACK POWDER COATING

REVISION HISTORY			
REV	DATE	BY	DESCRIPTION
F	13AUG2013	JX/MZ	PRN: P2013-1509

NON-LOCKING LOCKING

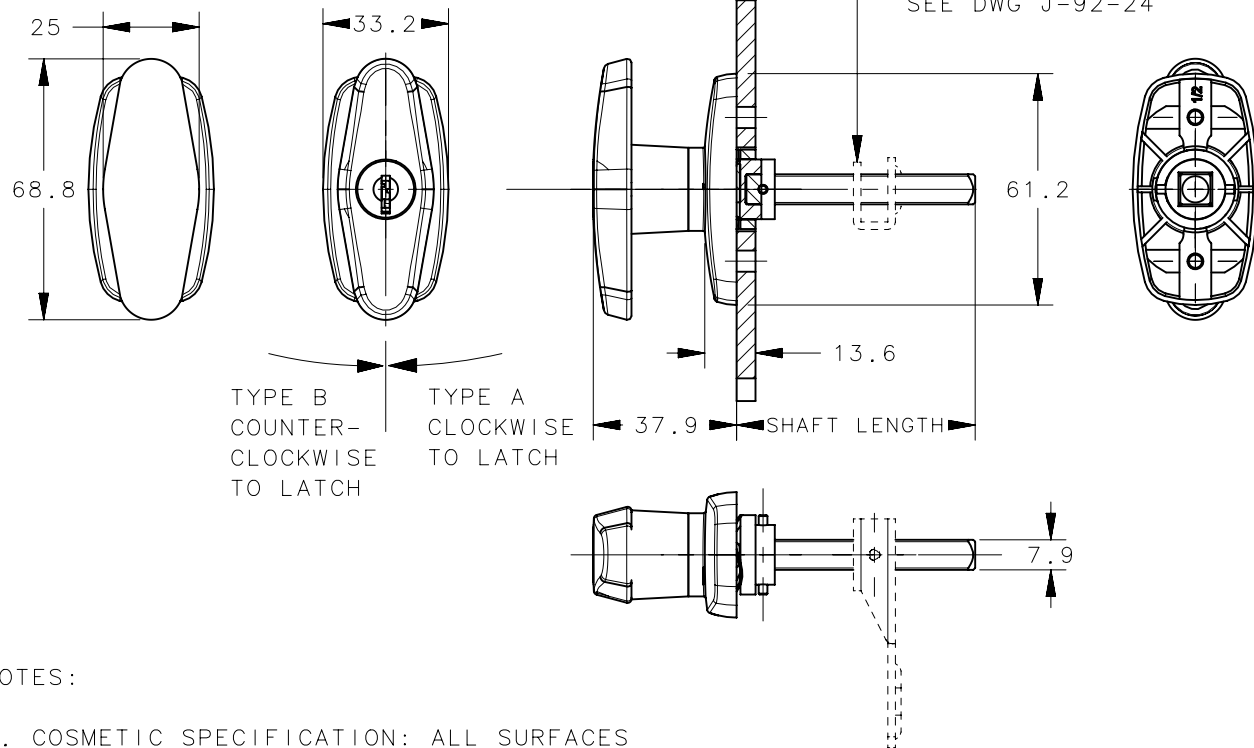

TYPE B
COUNTER-
CLOCKWISE
TO LATCH

TYPE A
CLOCKWISE
TO LATCH

PANEL PREPARATION

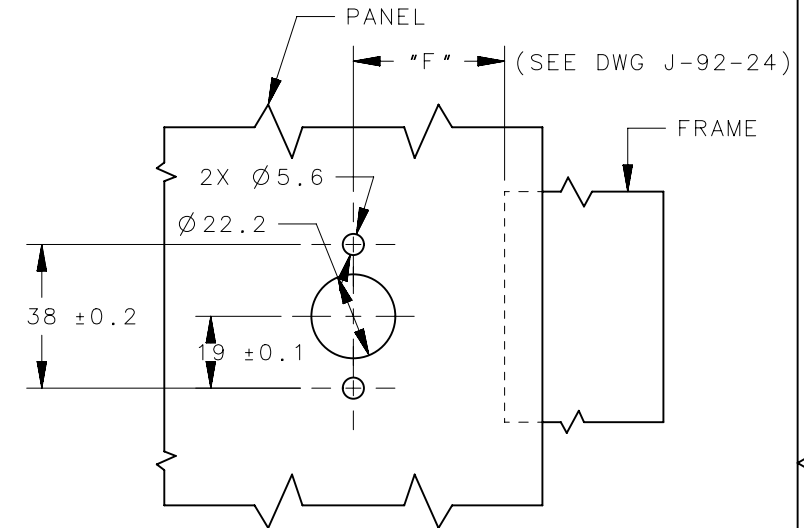

	SHAFT LENGTH	LOCKING		NON-LOCKING	
		TYPE A	TYPE B	TYPE A	TYPE B
BLACK	19.8 [.78]	92-61-111-10	92-61-211-10	92-61-101-10	92-61-201-10
	25.4 [1.00]	92-61-112-10	92-61-212-10	92-61-102-10	92-61-202-10
	38.1 [1.50]	92-61-113-10	92-61-213-10	92-61-103-10	92-61-203-10
	50.8 [2.00]	92-61-114-10	92-61-214-10	92-61-104-10	92-61-204-10
	63.5 [2.50]	92-61-115-10	92-61-215-10	92-61-105-10	92-61-205-10
CHROME	19.8 [.78]	92-61-111-50	92-61-211-50	92-61-101-50	92-61-201-50
	25.4 [1.00]	92-61-112-50	92-61-212-50	92-61-102-50	92-61-202-50
	38.1 [1.50]	92-61-113-50	92-61-213-50	92-61-103-50	92-61-203-50
	50.8 [2.00]	92-61-114-50	92-61-214-50	92-61-104-50	92-61-204-50
	63.5 [2.50]	92-61-115-50	92-61-215-50	92-61-105-50	92-61-205-50

NOTES:

- A. COSMETIC SPECIFICATION: ALL SURFACES UNLESS OTHERWISE NOTED ARE TO CONFORM IN SOUTHCO COSMETIC SPECIFICATIONS: S-121-01 - FOR CHROME PLATING AND S-121-03 - FOR POWDER COATING.
- B. FLANGE GASKET AVAILABLE (SOLD SEPARATELY): 92-70-G.

		THIRD ANGLE PROJECTION			 CONNECT • CREATE • INNOVATE	
		MILLIMETERS [IN]				
		TOLERANCES UNLESS OTHERWISE NOTED	DESCRIPTION			
SURFACE AREA		XXXXXmm ²	Cam Latch			
VOLUME		XXXXXmm ³	NO. 92 COMPRESSED "T" HANDLE ASSEMBLY			
PROPRIETARY ITEM		ALL DIMENSIONS WITHOUT TOLERANCES ARE FOR REFERENCE ONLY.	SIZE	SYSTEM	DWG NO.	
EXCEPT FOR USES EXPRESSLY GRANTED IN WRITING, INFORMATION DISCLOSED HEREON IS CONFIDENTIAL AND ALL RIGHTS, PATENT AND OTHERWISE, ARE RESERVED BY SOUTHCO, INC.			A4	NX	J-92-61-1	
		PER ASME Y14.5M-1994	DRAWN BY	DATE	SCALE	SHEET
			RLR/MDY	05JAN2005	1:1	1 OF 1