

REVISION HISTORY			
REV	DATE	BY	DESCRIPTION
N	18JUL2024	GJL/SAK	PRN: P2024-1249

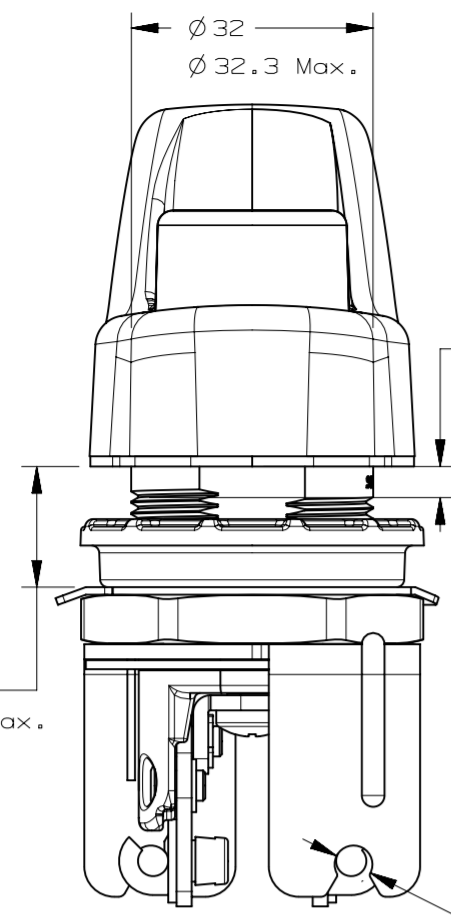

AC-40-1YZ

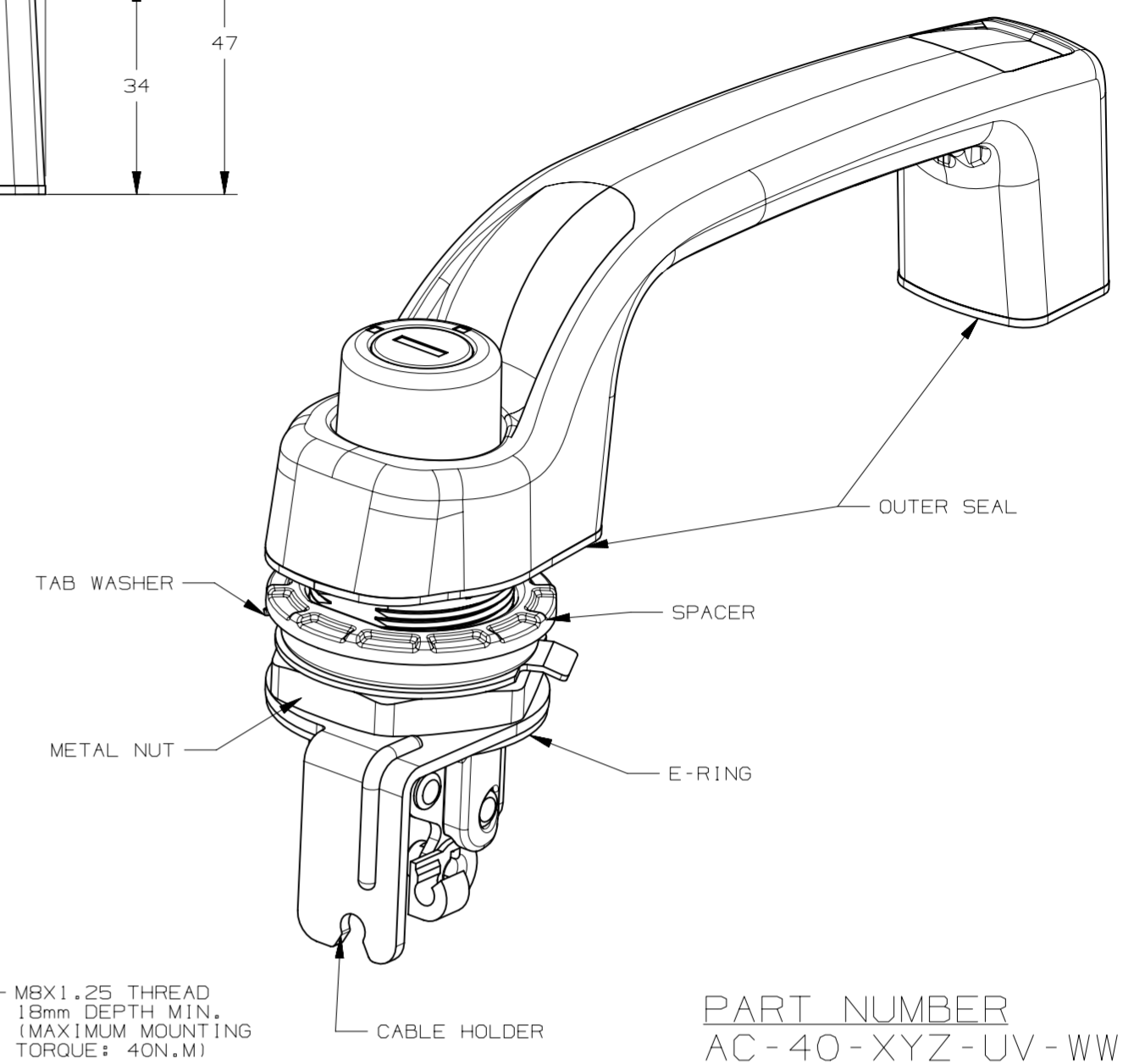
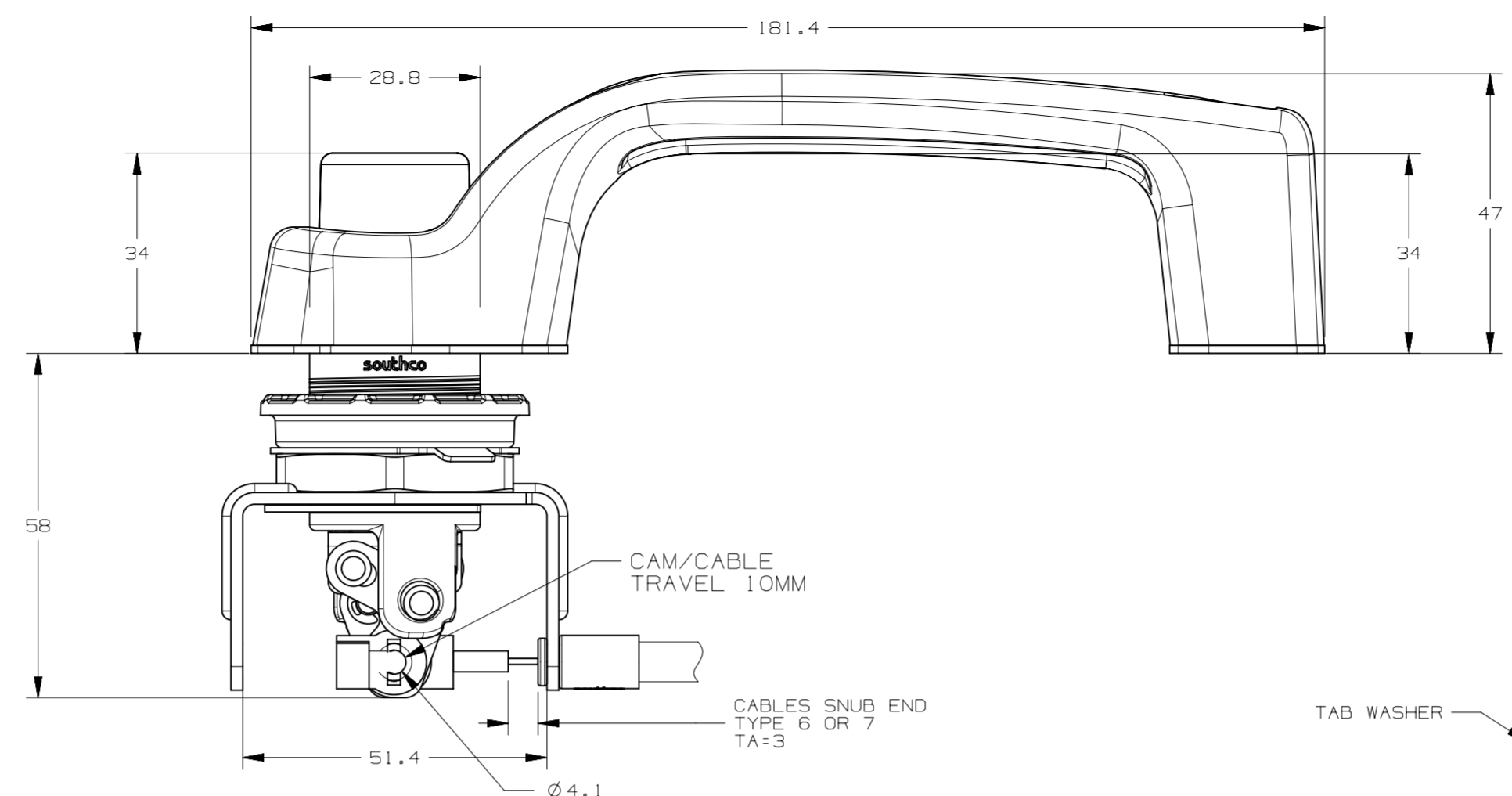

PART NUMBER
AC-40-XYZ-UV-WWWW

END STYLE
LOCKING OPTION
MOUNTING METHOD
HANDLE MATERIAL
BUTTON FINISH
KEY CODES

- END STYLE - X:**
 1-WITH CAM ATTACHMENT
 3-WITHOUT CAM ATTACHMENT (FOR METHODS 1 OR 2 ONLY)
- LOCKING OPTION - Y:**
 0-NON-LOCKING
 1-REVERSIBLE KEY (NO KEYS - R001)
 2-REVERSIBLE KEY (2 KEYS INCLUDED - R001)
 3-REVERSIBLE KEY (MULTIPLE KEY CODES - 2 KEYS INCLUDED-KDXX)
 4-STANDARD KEY (NO KEYS - CH751)
 5-STANDARD KEY (2 KEYS INCLUDED - CH751)
 6-STANDARD KEY (MULTIPLE KEY CODES - 2 KEYS INCLUDED-MKXX)
 7-14603 KEY CODE (2 KEYS INCLUDED)
 9-WITHOUT LOCK PLUG INSTALLED
- MOUNTING METHOD - Z (SEE SHEET 2):**
 1-CABLE PARALLEL (OR NO CABLE), WITH SPACER MOUNTING - MUST HAVE IF GLASS PANEL
 2-CABLE PARALLEL (OR NO CABLE), WITHOUT SPACER MOUNTING
 3-CABLE CROSS, WITH SPACER MOUNTING - MUST HAVE IF GLASS PANEL (END STYLE 1 ONLY)
 4-CABLE CROSS, WITHOUT SPACER MOUNTING (END STYLE 1 ONLY)
- HANDLE MATERIAL - U:**
 1-BLACK GF NYLON WITH ZINC HOUSING INSERT
 2-BLACK GF NYLON WITH STAINLESS STEEL HOUSING INSERT
- BUTTON MATERIAL & FINISH - V:**
 1-NYLON WITH BLACK MOLDING
- KEY CODES (ONLY USE WHEN Y=3 OR 6) - WWWW:**
 KD10-KEYED DIFFERENTLY (10 CODES)
 MK10-MASTER KEYED, KEYED DIFFERENTLY, 10 CODES (ONLY USED IF Y= 6)

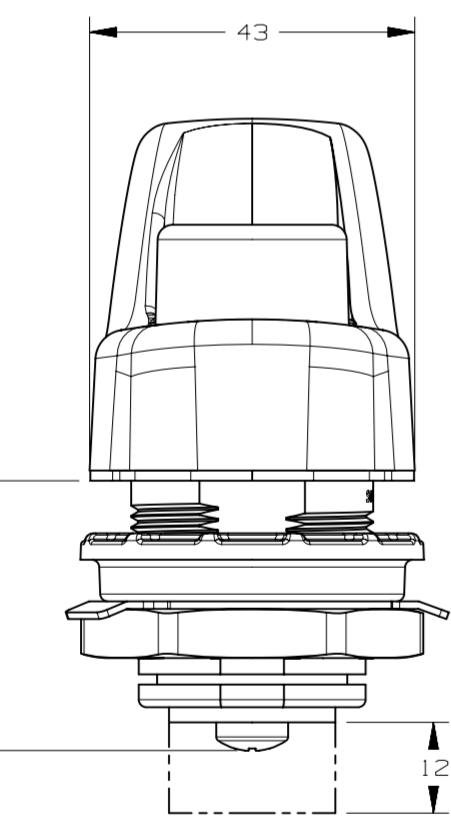

AC-40-3YZ

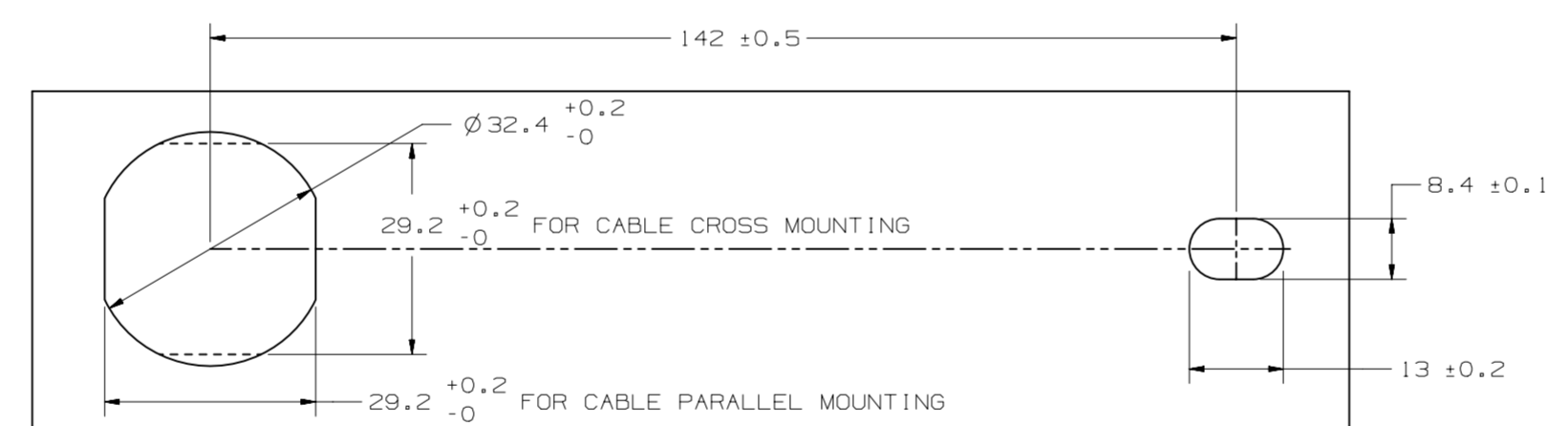

PANEL PREPARATION
THICKNESS: 1MM TO 16.8MM Max.

- NOTE:**
- A. HOUSING SEAL, SPACER, METAL NUT, CABLE HOLDER WITH E-RING PACKAGE SEPARATELY
 - B. MATERIAL AND FINISH:
 - BUTTON: REINFORCED NYLON, SEE V;
 - HOUSING: ZINC DIE CAST OR STAINLESS STEEL, SEE U FOR HOUSING MATERIAL AND FINISH
 - LOCK PLUG: ZINC DIE CAST WITH BRIGHT STAINLESS COVER
 - MOUNTING NUT, ROTATION SHAFT: ZINC DIE CAST OR STAINLESS STEEL,
 - PAWL, PAWL WASHER, RIVET: STAINLESS STEEL, PASSIVATED
 - E-RING, SCREW, SPRING: STAINLESS STEEL, PASSIVATED
 - C. INSTALLATION:
 1. INSERT ACTUATOR HANDLE WITH SEAL INTO HOLE OF DOOR, CHECK FOR PROPER ORIENTATION AND OPERATION
 2. INSTALL SPACER, TAB WASHER, METAL NUT, M8X1.25 SCREW (NOT SUPPLIED, CUSTOMER NEED SELECT APPROPRIATE LENGTH PER PANEL THICKNESS) ONTO HOUSING, RECOMMENDED TIGHTENING TORQUE (M32X1.5 NUT):
 FOR STAINLESS STEEL NUT AND HOUSING: 100Nm MAX.
 FOR ZINC ALLOY NUT AND HOUSING: 50Nm MAX.
 RECOMMENDED TIGHTENING TORQUE (M8X1.25): 40Nm MAX.
 3. CLIP ONE SIDE OF TAB WASHER TO HOLD METAL NUT, MUST TOUCH WITH THE SIDE WALL OF NUT, MAXIMUM CLEARANCE 1MM.
 4. FOR CABLE/ROD CONNECTION: INSTALL THE CABLE HOLDER AND CLIP WITH E-RING, MOUNTING CABLE ON PAWL WITH HOLDER
 - D. ASSEMBLY CAN BE CONFIGURED WITH 1 OR 2 CABLES, RECOMMENDED SOUTHCO CABLE TYPE 6 OR 7. USE FITTING TYPE B OR K (L FITTING) FOR ACTUATOR END CABLES SOLD SEPARATELY. REFER TO CABLE CONFIGURATOR TOOL ON SOUTHCO.COM
 - E. SEE SHEET 2 FOR CABLE MOUNTING DIRECTION WITH LOCK-UNLOCK ORIENTATION

(WITHOUT CAM ATTACHMENT FOR DIRECT ACTUATION. SAME AS AC-40-1YZ EXCEPT OF NO CABLE HOLDER OR CAM ASSEMBLY)

AC-40-XYZ-UV-WWWW		SEE NOTES	SEE NOTES
PART NUMBER	MATERIAL	FINISH	
	THIRD ANGLE PROJECTION		
	MILLIMETERS [IN]		
SURFACE AREA	TOLERANCES UNLESS OTHERWISE NOTED	DESCRIPTION	
VOLUME	ALL DIMENSIONS WITHOUT TOLERANCES ARE FOR REFERENCE ONLY.	PUSH BUTTON HANDLE ENTRY ACTUATOR	
PROPRIETARY ITEM	EXCEPT FOR USES EXPRESSLY GRANTED IN WRITING, INFORMATION DISCLOSED HEREON IS CONFIDENTIAL AND ALL RIGHTS, PATENT AND OTHERWISE, ARE RESERVED BY SOUTHCO, INC.	SIZE	SYSTEM
		A2	NX
		DWG NO.	J-AC-40
	PER ASME Y14.5M-2009	DRAWN BY	MZ
		DATE	10FEB2010
		SCALE	1:1
		SHEET	1 OF 2



8

7

6

5

4

3

2

1

REVISION HISTORY			
REV	DATE	BY	DESCRIPTION
N	18JUL2024	GJL/SAK	PRN: P2024-1249

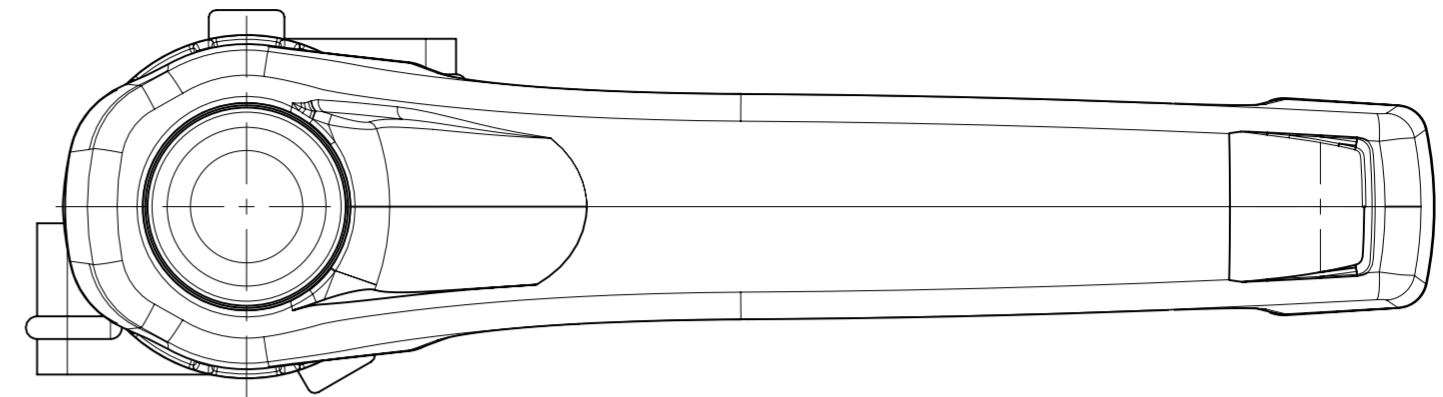

NON-LOCKING VERSION (Y=0)

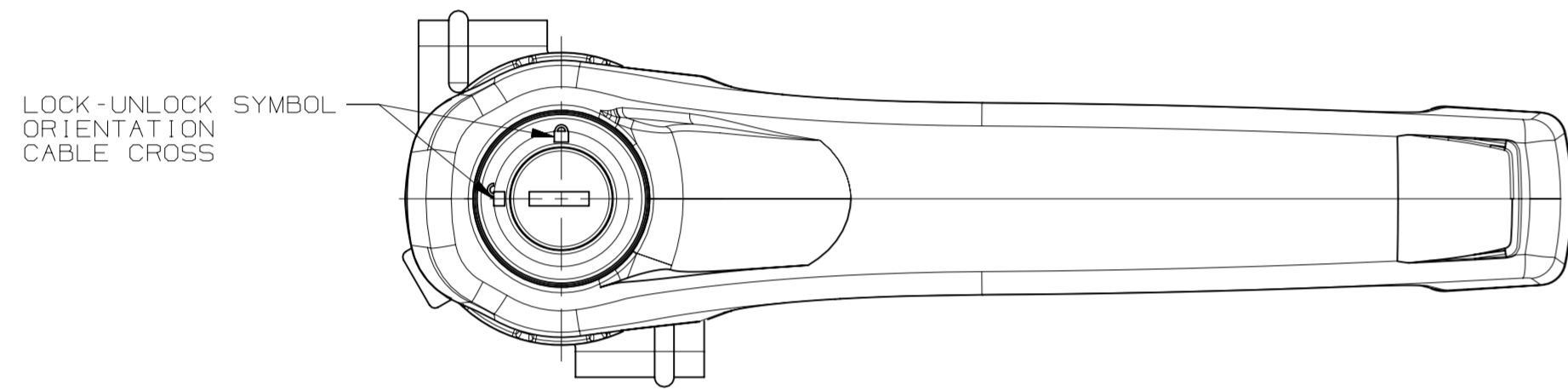

LOCK-UNLOCK SYMBOL
ORIENTATION
CABLE CROSS

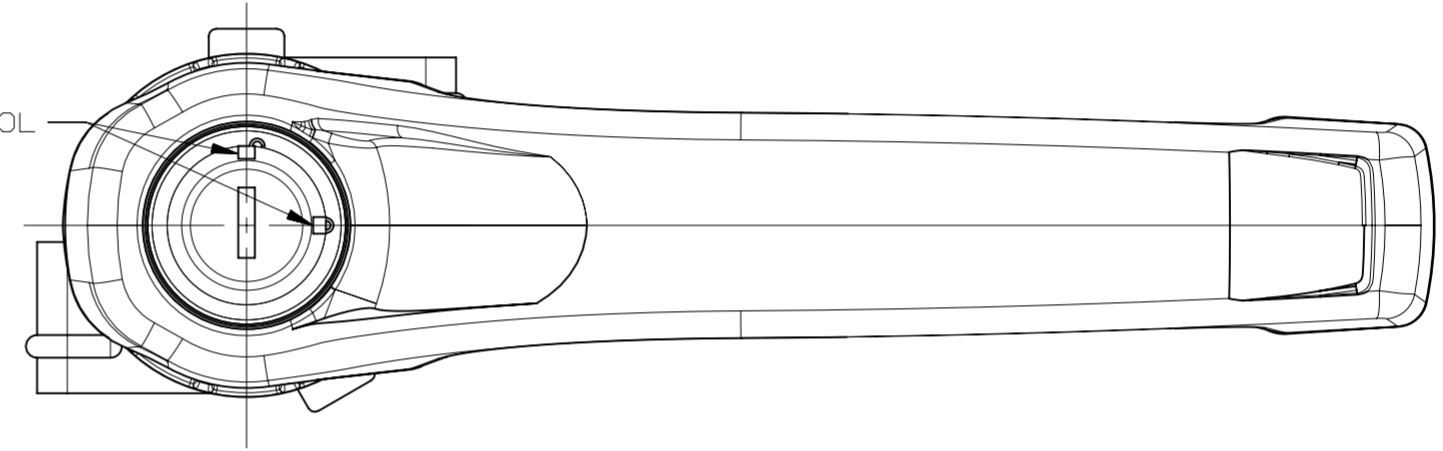

LOCK-UNLOCK SYMBOL
ORIENTATION
CABLE PARALLEL

LOCKING VERSION

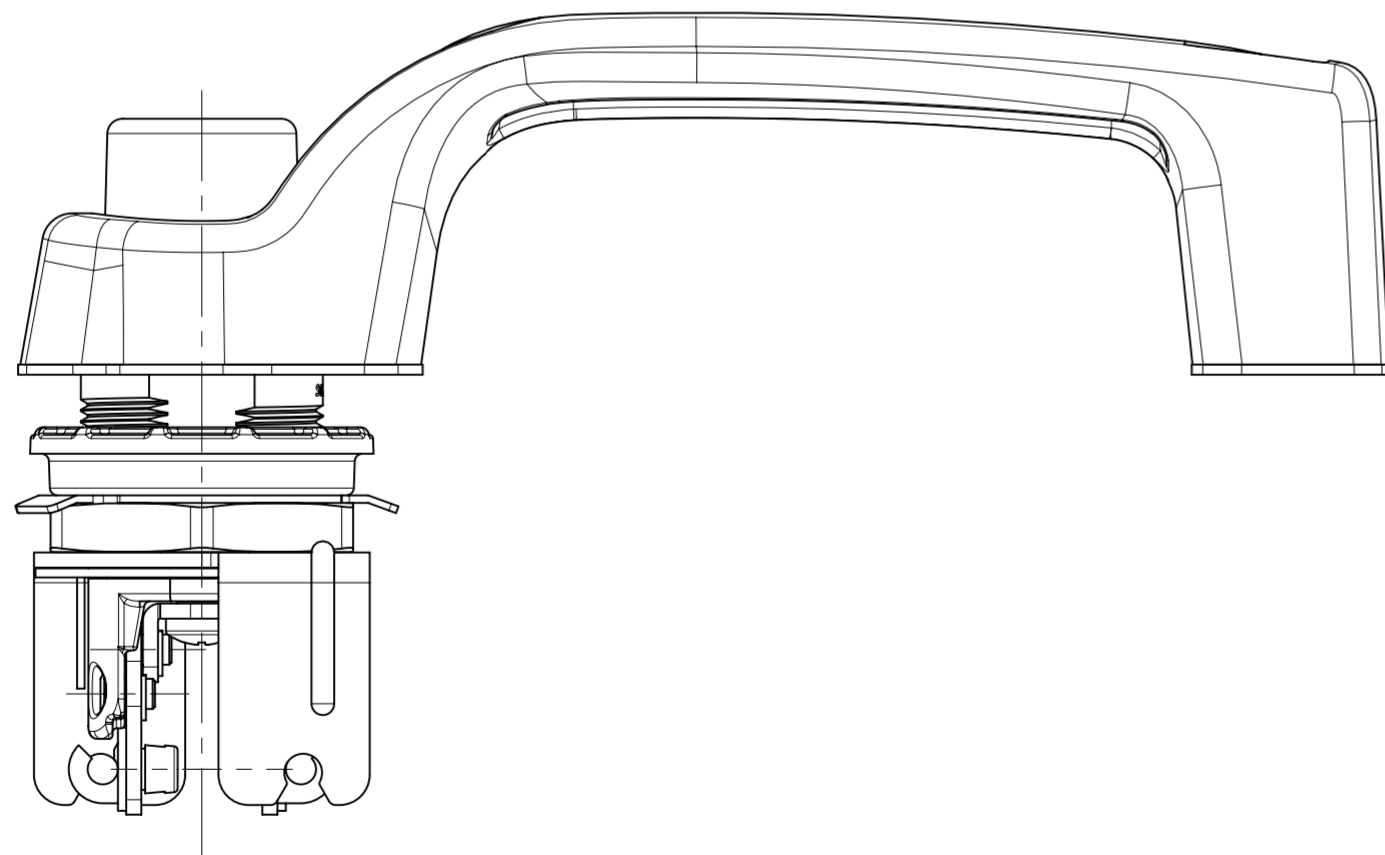

CABLE CROSS MOUNTING
Z=3 OR 4

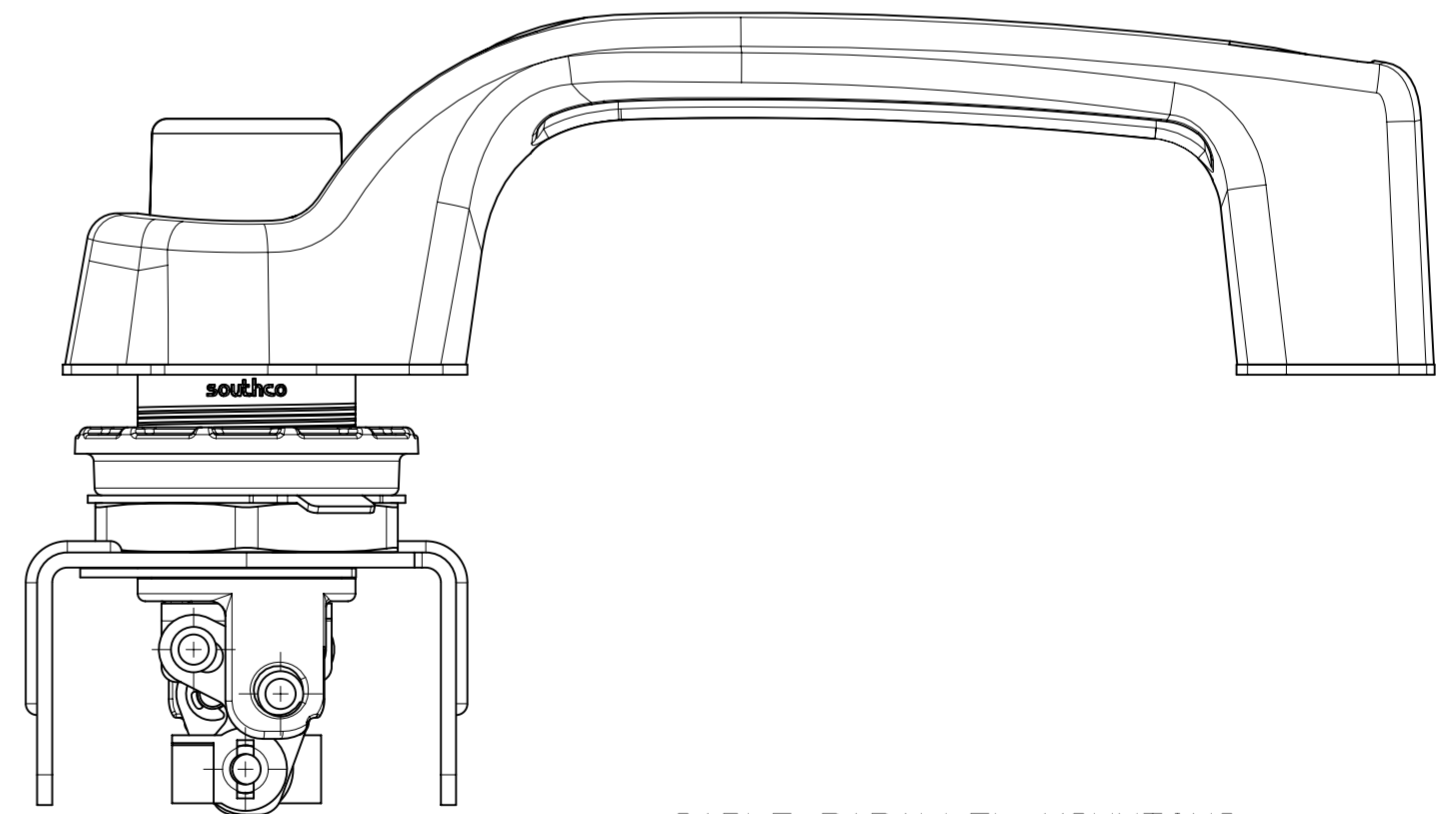

CABLE PARALLEL MOUNTING
Z=1 OR 2

THIRD ANGLE PROJECTION		southco CONNECT · CREATE · INNOVATE	
MILLIMETERS [IN]			
TOLERANCES UNLESS OTHERWISE NOTED		DESCRIPTION PUSH BUTTON HANDLE ENTRY ACTUATOR	
ALL DIMENSIONS WITHOUT TOLERANCES ARE FOR REFERENCE ONLY.		SIZE A2	SYSTEM NX
PROPRIETARY ITEM EXCEPT FOR USES EXPRESSLY GRANTED IN WRITING, INFORMATION DISCLOSED HEREIN IS CONFIDENTIAL AND ALL RIGHTS, PATENT AND OTHERWISE, ARE RESERVED BY SOUTHCO, INC.		DWG NO. J-AC-40	SCALE 1:1
PER ASME Y14.5M-2009		DRAWN BY MZ	DATE 25MAY2010
		SHEET 2 OF 2	

8

7

6

5

4

3

2

1