

NOTES:

A. MATERIAL AND FINISH:
ELECTRONIC ACTUATOR: PLASTIC (NYLON AND ACETAL), AND METAL COMPONENTS

B. ELECTRICAL SPECIFICATIONS:
OPERATING VOLTAGE: 5 VDC +/-15%
TYPICAL OPERATING CURRENT: LESS THEN 350 MILLIAMPS AT 5 VDC
PEAK / STALL OPERATING CURRENT: 0.5A MAX (NO STALL PROTECTION INCLUDED)
TOTAL STANDBY CURRENT: RETRACTED: 0 Amp
EXTENDED: NA
TRIGGER COMMAND: ACTUATOR WILL FULLY EXTENDED AND THEN BE FREE TO RETRACT
CONTROL SIGNAL PULSE REQUIRED FOR TRIGGER COMMAND: 5 VDC +/-15%, 0.5 Amp MAX PULSE
RECOMMENDED MINIMUM PULSE DURATION 300 MILLISECONDS
RECOMMENDED MAXIMUM PULSE DURATION 400 MILLISECONDS

TYPICAL ACTUATOR TRANSIT TIME TO CYCLE EXTENDED AND RETRACTED: 600 MILLISECONDS NO LOAD, 1.0 SECOND MAX
OPERATING TEMPERATURE RANGE: -20C TO 60C NON-ICING, NON-CONDENSING ENVIRONMENT
OPERATING HUMIDITY: 85% MAX.
NOT INTENDED FOR DIRECT EXPOSURE TO OUTDOOR ELEMENTS.

CAUTION! NO STALL PROTECTION IS PROVIDED IN ACTUATOR. USE APPROPRIATE CIRCUIT PROTECTION.
PRODUCT PERFORMANCE AND SPEED(TRANSIT TIME) WILL VARY WITH INPUT VOLTAGE, TEMPERATURE, AND APPLIED LOAD.
OPERATING SPEED WILL BE SLOWEST WITH LOWEST VOLTAGE, HIGH LOAD AND LOW TEMPERATURE.
OPERATING SPEED WILL BE FASTEST WITH HIGHEST VOLTAGE, NO LOAD AND HIGH TEMPERATURE.

C. ELECTRICAL CONNECTIONS AND HOOKUP:
A BASIC SWITCH CONTROL ELECTRICAL HOOKUP DIAGRAM IS PROVIDED FOR REFERENCE.
CONSULT WITH A SOUTHCO REPRESENTATIVE FOR ADDITIONAL ELECTRICAL HOOKUP INFORMATION.

- CONNECT POWER, GROUND AND CONTROL SIGNAL WIRES TO AN APPROPRIATE DC POWER SUPPLY
- A DC POWER SUPPLY CAPABLE OF SUPPLYING 5 VDC +/-15% AT 0.5 AMP MINIMUM PER ACTUATOR IS RECOMMENDED
- POWER MUST BE AVAILABLE TO OPERATE THE ACTUATOR AND MUST REMAIN AVAILABLE DURING THE FULL TRANSIT TIME OF THE ACTUATOR DURING EXTENDING OR RETRACTING.
- PRODUCT PERFORMANCE AND SPEED WILL VARY WITH INPUT VOLTAGE. A VOLTAGE REGULATED POWER SUPPLY IS RECOMMENDED.

CAUTION! ACTUATOR CAN BE DAMAGED IF WIRED INCORRECTLY, OR IF IMPROPER VOLTAGE IS APPLIED!
WIRE COLOR CODE / CONNECTOR PIN ASSIGNMENT: SEE CONNECTOR PINOUT LOCATION DETAILS
PIN1/BROWN WIRE: GROUND(-)
PIN2/RED WIRE: POWER(+)
PIN3/ORANGE WIRE: CONTROL PULSE(+)

D. ELECTRICAL OPERATION:
TO TRIGGER THE ACTUATOR:
PROVIDE THE FOLLOWING CONTROL SIGNAL TO THE ORANGE WIRE OR CONNECTOR PIN 3

- RECOMMENDED CONTROL SIGNAL HIGH(+5VDC) FOR A MINIMUM OF 300 MILLISECONDS, AND A MAXIMUM 400 MILLISECONDS
- IF THE CONTROL SIGNAL PULSE IS TOO SHORT THE ACTUATOR WILL NOT START IT'S CYCLE.
- IF THE CONTROL SIGNAL PULSE IS TOO LONG THE ACTUATOR MAY CYCLE MORE THAN ONCE.
- THE ACTUATOR WILL EXTENDED AND PUSH A MECHANICAL LOAD AND THEN BE FREE TO RETRACT. THE ACTUATOR WILL NOT PULL A LOAD.

CAUTION! TO PREVENT LONG TERM DAMAGE TO THE ELECTRICAL COMPONENTS IT IS IMPORTANT TO NOT BLOCK (STALL) THE ACTUATOR DURING ELECTRICAL OPERATION.

- THE ACTUATOR CANNOT REVERSE A CYCLE.
- THE ACTUATOR MUST BE ALLOWED TO REACH ITS FULL EXTENDED TRAVEL TO COMPLETE A CYCLE.
- IF POWER FAILS, OR IS REMOVED DURING TRANSIT OF THE ACTUATOR, THE ACTUATOR MAY STOP IN AN INDETERMINANT EXTENDED STATE AND WILL TRY TO COMPLETE ITS CYCLE WHEN POWER IS RESUMED.
- IT IS RECOMMENDED TO LIMIT POWER ON TIME TO MINIMISE POTENTIAL STALL CONDITION TIME.

E. OPTIONAL CONNECTOR:

MANUFACTURER: MOLEX, SERIES: MICROFIT 3.0 OR EQUIVALENT
- CONNECTOR RECEPTICAL, SINGLE ROW, 3 CIRCUITS, 3mm, MOLEX P/N: 43645-0300
- CONTACTS: FEMALE CRIMP TERMINAL (SOCKET) MOLEX P/N: 43030-0010TBD
WIRE: 26 AWG STYLE AWM UL1007/1569, BONDED 3C
WIRE LENGTH: SEE TABLE FOR AVAILABLE LENGTHS
MATE FOR CONNECTOR (NOT SUPPLIED)
MANUFACTURER: MOLEX, SERIES: MICROFIT 3.0
- CONNECTOR PLUG 3 CIRCUITS 3 mm, MOLEX P/N: 43640-0301
- RECOMMENDED CONTACTS (3 MAX REQUIRED): MOLEX, MALE CRIMP TERMINAL (PIN), MOLEX P/N: 43031-0007
- RECOMMENDED WIRE GAGE: 24 AWG

F. MOUNTING:

-TWO Ø3.25MM THROUGH HOLES ARE PROVIDED FOR THROUGH HOLE MOUNTING WITH M3 OR 4-40 BOLTS, OR FOR USE WITH M4 THREAD FORMING SCREWS FOR PLASTICS COMPATIBLE WITH A Ø3.25 MM PILOT HOLE.
-AN OPTIONAL MOUNTING KIT INCLUDING A MOUNTING PLATE AND SCREWS IS AVAILABLE FOR USE WITH A SOUTHCO R4-05 SERIES ROTARY LATCH
SEE J-AC-EM-020 FOR PART NUMBERS AND MORE INFORMATION.
-MAXIMUM ALLOWABLE TORQUE ON THREAD FORMING SCREWS 135 N.cm [12.0 in.lbs]
-MAXIMUM ALLOWABLE TORQUE ON THROUGH HOLE M3 OR 4-40 SOCKET HEAD CAP SCREWS 60 N.cm [5.3 in.lbs]

G. PACKAGED

IN INDIVIDUAL BAGS OR ADD -1 TO PART NUMBER FOR BULK TRAY PACKAGING
EXAMPLE: AC-EM-050-5010 INDIVIDUAL PACKAGE
AC-EM-050-5010-1 BULK TRAY PACKAGING, 100 PIECES PER BOX

REVISION HISTORY			
REV	DATE	BY	DESCRIPTION
B	12MAR2018	ELA/GGG	PRN: P2018-0414

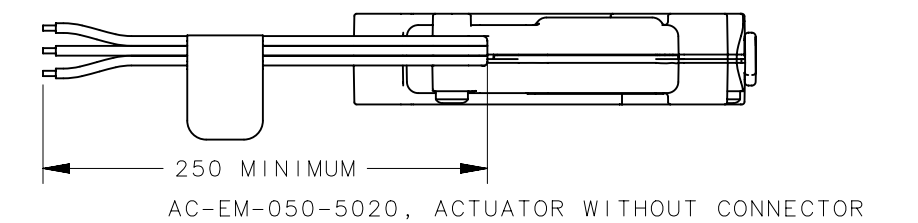
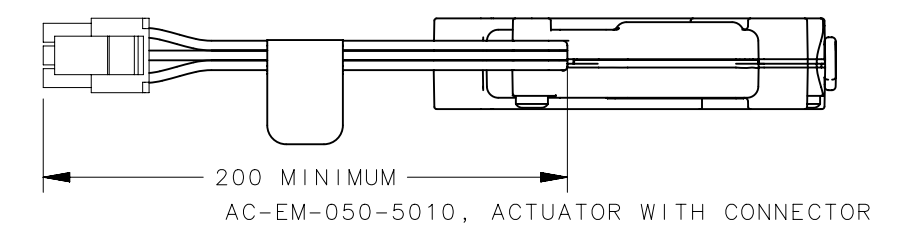
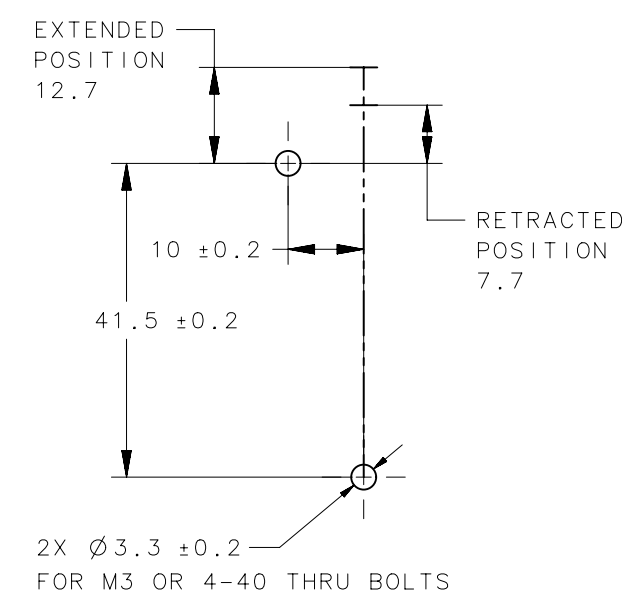
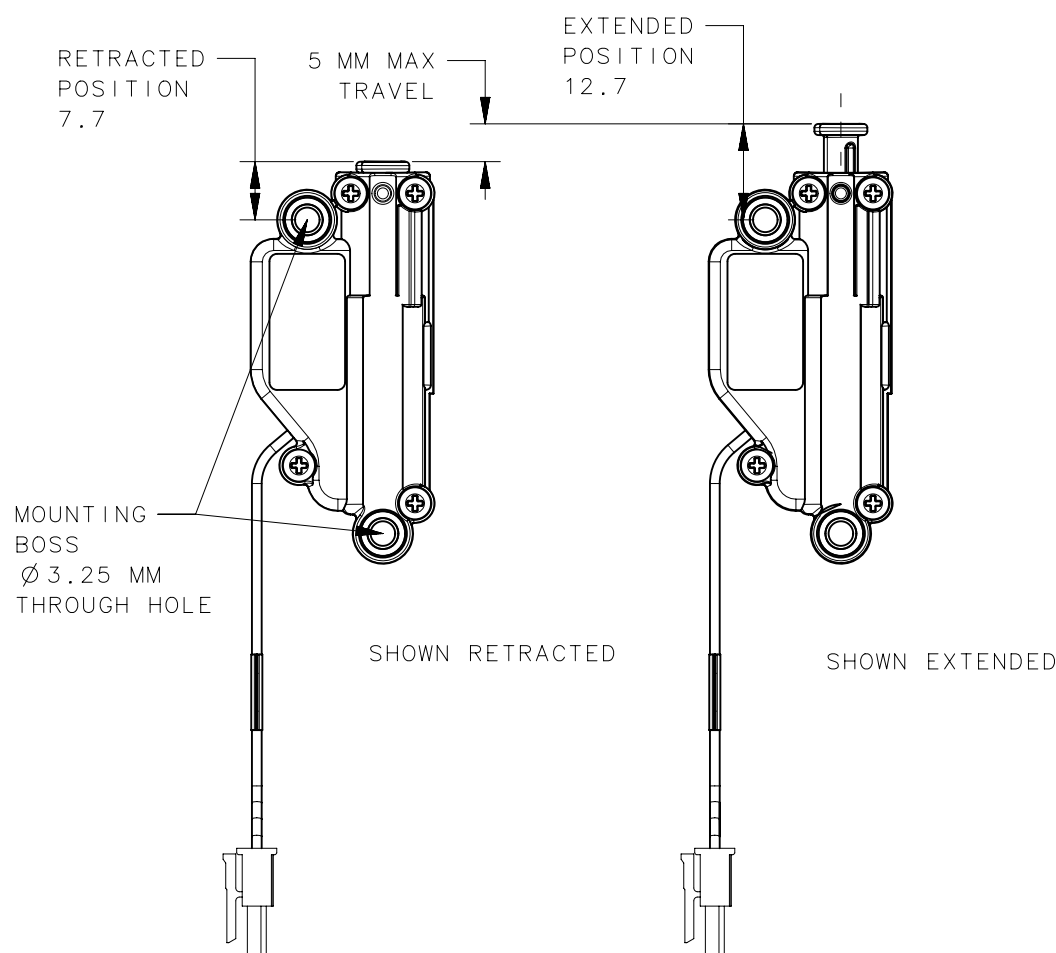
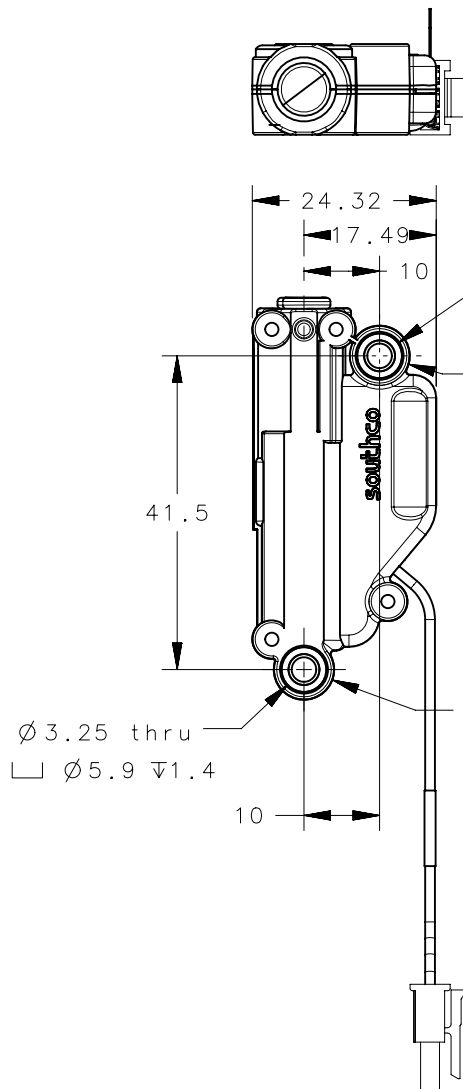
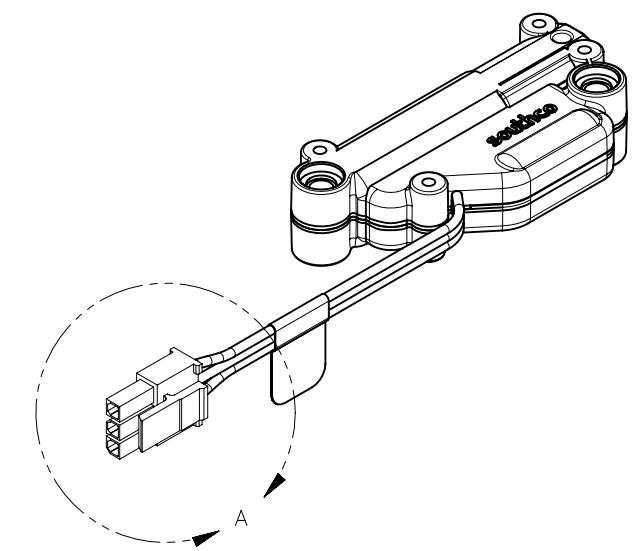
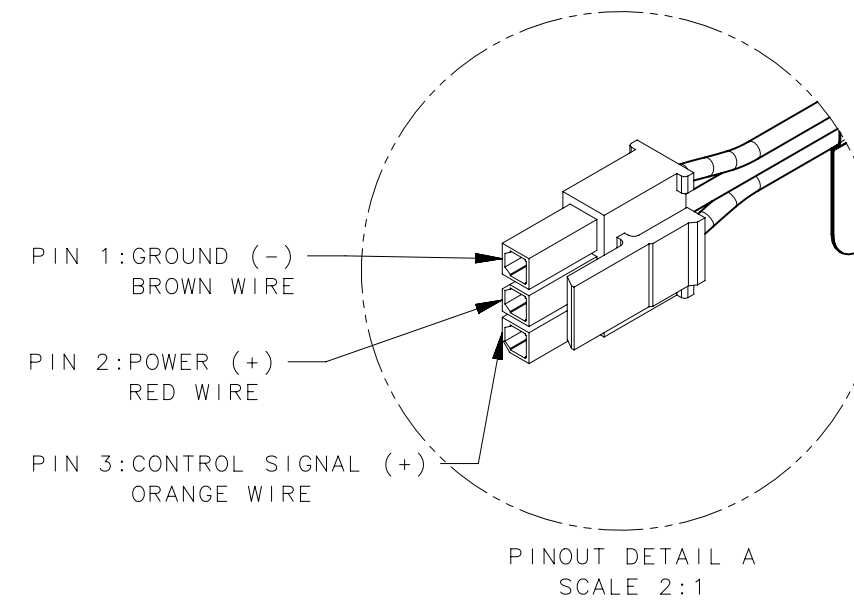
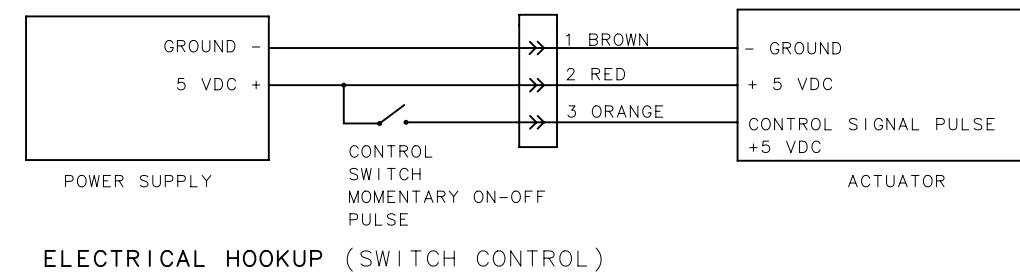

PANEL PREPARATION ACTUATOR ONLY
SEE NOTE F

AC-EM-050-5010	5V, ELECTRO-MECHANICAL ACTUATOR, WITH CONNECTOR
AC-EM-050-5020	5V, ELECTRO-MECHANICAL ACTUATOR, WITHOUT CONNECTOR
ACTUATOR PART NUMBER CONNECTOR TYPE	
southco CONNECT · CREATE · INNOVATE	
ELECTRONIC ACCESS SOLUTION ELECTRO-MECHANICAL ACTUATOR	
THIRD ANGLE PROJECTION	SIZE SYSTEM NX DWG NO. J-AC-EM-05-1
MILLIMETERS [IN]	SCALE 1:1 SHEET 1 OF 2
SURFACE AREA mm ²	DATE 04MAY2017
VOLUME mm ³	SCALE 1:1 SHEET 1 OF 2
PROPRIETARY ITEM EXCEPT FOR USES EXPRESSLY GRANTED IN WRITING, INFORMATION DISCLOSED HEREON IS CONFIDENTIAL AND ALL RIGHTS, PATENT AND OTHERWISE, ARE RESERVED BY SOUTHCO, INC.	DRAWN BY GGG
PER ASME Y14.5M-1994	DATE 04MAY2017

REVISION HISTORY			
REV	DATE	BY	DESCRIPTION
B	12MAR2018	ELA/GGG	PRN: P2018-0414

NOTES

- H. THE AC-EM-05 ACTUATOR IS COMPATIBLE WITH BOTTOM ACTUATED R4-05 ROTARY LATCHES
 PART NUMBERS: R4-05-XX-505-10 AND R4-05-XX-505-20. SEE J-R4-05-10, J-R4-05-20 FOR LATCH INFORMATION.
- R4-05 LATCH AND NECESSARY MOUNTING HARDWARE SOLD SEPARATELY.
 - AN OPTIONAL MOUNTING KIT INCLUDING A MOUNTING PLATE AND SCREWS IS AVAILABLE FOR USE WITH SOUTHCO R4-05 SERIES ROTARY LATCH SEE J-AC-EM-020 FOR PART NUMBERS AND MORE INFORMATION.
 - MAXIMUM ALLOWABLE TORQUE WITH ACTUATOR M4 THREAD FORMING SCREWS IS 135 N.cm [12.0 in.lbs]
 - MAXIMUM ALLOWABLE TORQUE WITH ACTUATOR THROUGH HOLE M3 OR 4-40 SOCKET HEAD CAP SCREWS 60 N.cm [5.3 in.lbs]
 - CONTACT SOUTHCO.COM FOR RECOMMENDED ACCESSORIES.
- CAUTION! IT IS IMPORTANT TO NOT OBSTRUCT THE MOTION OF THE LATCH TRIGGER DURING ELECTRICAL OPERATION TO PREVENT LONG TERM DAMAGE TO THE ELECTRICAL COMPONENTS IN THE ACTUATOR.

PANEL PREPARATION
AC-EM-05 ACTUATOR WITH R4-05 LATCH

SEE NOTE H

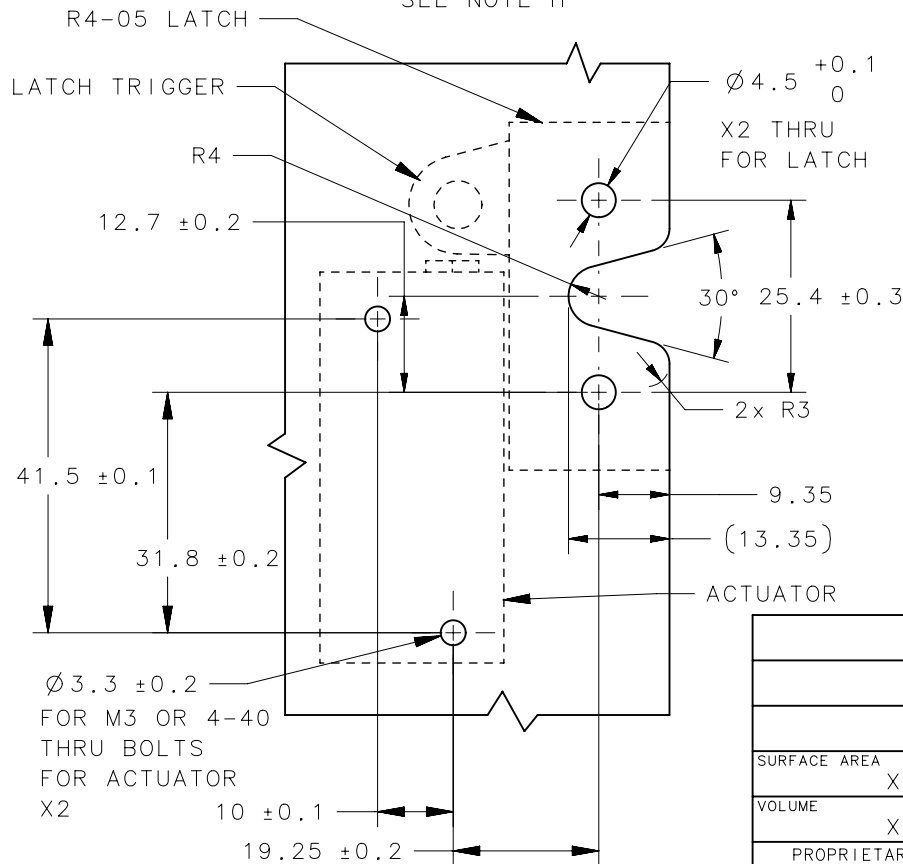

	THIRD ANGLE PROJECTION	
	MILLIMETERS [IN]	
SURFACE AREA	XXXXXmm ²	
VOLUME	XXXXXmm ³	
PROPRIETARY ITEM		
EXCEPT FOR USES EXPRESSLY GRANTED IN WRITING, INFORMATION DISCLOSED HEREON IS CONFIDENTIAL AND ALL RIGHTS, PATENT AND OTHERWISE, ARE RESERVED BY SOUTHCO, INC.		
	TOLERANCES UNLESS OTHERWISE NOTED	
	ALL DIMENSIONS WITHOUT TOLERANCES ARE FOR REFERENCE ONLY	
	PER ASME Y14.5M-1994	

southco [®]			
CONNECT • CREATE • INNOVATE			
DESCRIPTION			
ELECTRONIC ACCESS SOLUTION ELECTRO-MECHANICAL ACTUATOR			
SIZE	SYSTEM	DWG NO.	
A4	NX	J-AC-EM-05-1	
DRAWN BY	DATE	SCALE	SHEET
GGG	12MAR2018	1:1	2 OF 2