

6

5

4

3

2

1

ITEM	PART	QTY	MATERIAL	FINISH	NOTES
20	INSTRUCTION FOR MOUNTING AND USE	1	N/A	N/A	NOT SHOWN
19	4mm ALLEN KEY	1	STEEL	BLACK OXIDE	LOCATED IN HARDWARE PACK
18	2mm ALLEN KEY	1	STEEL	BLACK OXIDE	LOCATED IN HARDWARE PACK
17	M4 x 10Lg SCREW	4	STEEL	ZINC PLATED	LOCATED IN HARDWARE PACK
16	M6 x 15Lg ROUND HEAD SCREW	1	STAINLESS STEEL	NATURAL	
15	SPRING WASHER	1	STEEL	ZINC PLATED	
14	WASHER	1	STAINLESS STEEL	NATURAL	
13	M4 x 6Lg SET SCREW	1	STEEL	ZINC PLATED	
12	WALL MOUNT	1	DIE CAST ALUMINIUM	PAINTED	
11	BUSHING	1	POM	POM	
10	HOUSING	1	DIE CAST ALUMINIUM	PAINTED	
9	PIN	1	DIE CAST ALUMINIUM	PAINTED	
8	WASHER	2	COPPER	NATURAL	
7	3/8" HEX BOLT	1	ALLOY STEEL	ZINC PLATED	
6	M6 x 14Lg CSK HEAD SCREW	2	STEEL	PAINTED	
5	ADAPTER	1	DIE CAST ALUMINIUM	PAINTED	
4	Ø28 WASHER	1	NYLON	NATURAL	
3	MONITOR MOUNTING PLATE	1	STEEL	PAINTED	
2	Ø10 WASHER	3	STEEL	ZINC PLATED	
1	3/8" NYLON INSERT NUT	1	STEEL	ZINC PLATED	

REVISION HISTORY			
REV	DATE	BY	DESCRIPTION
B	26FEB2020	SKB/DMS	PRN: P2020-0230

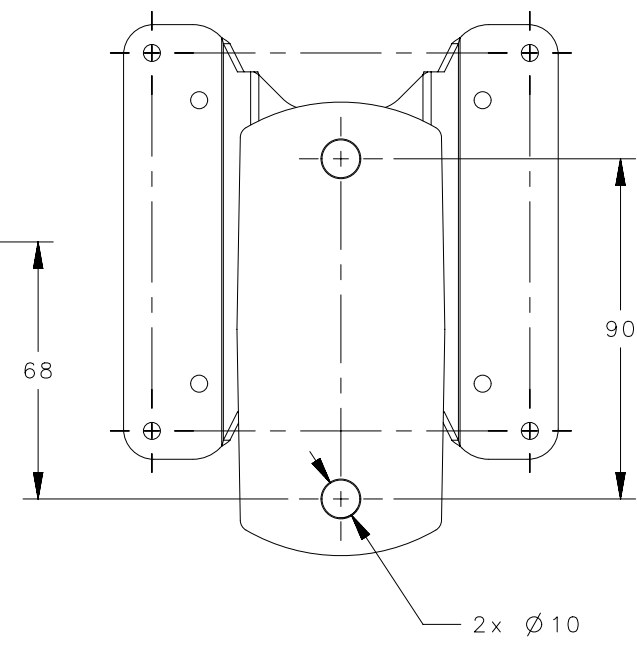
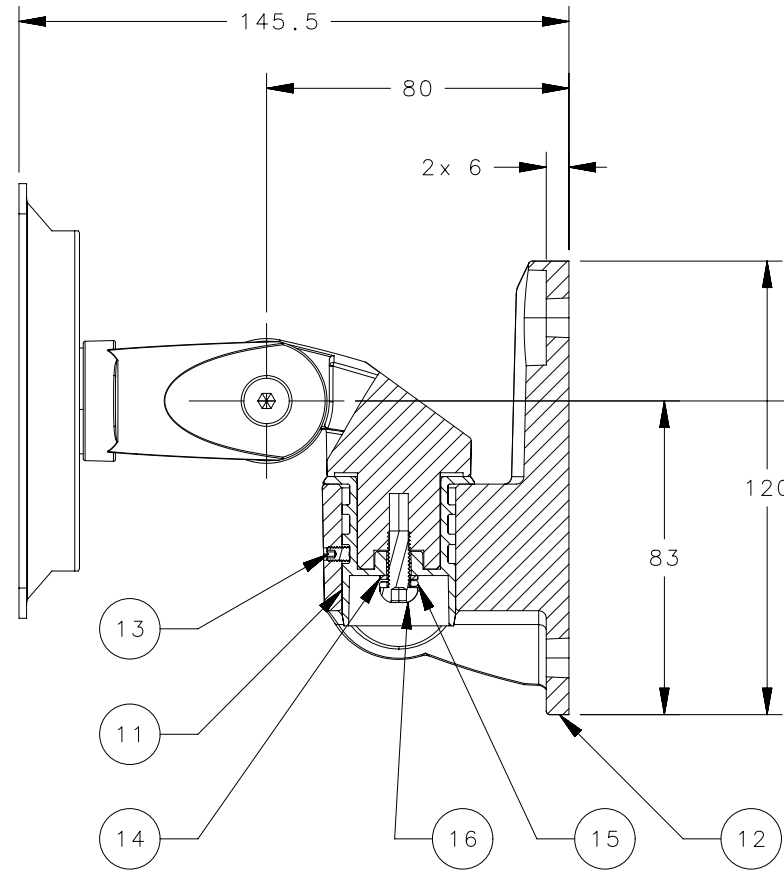
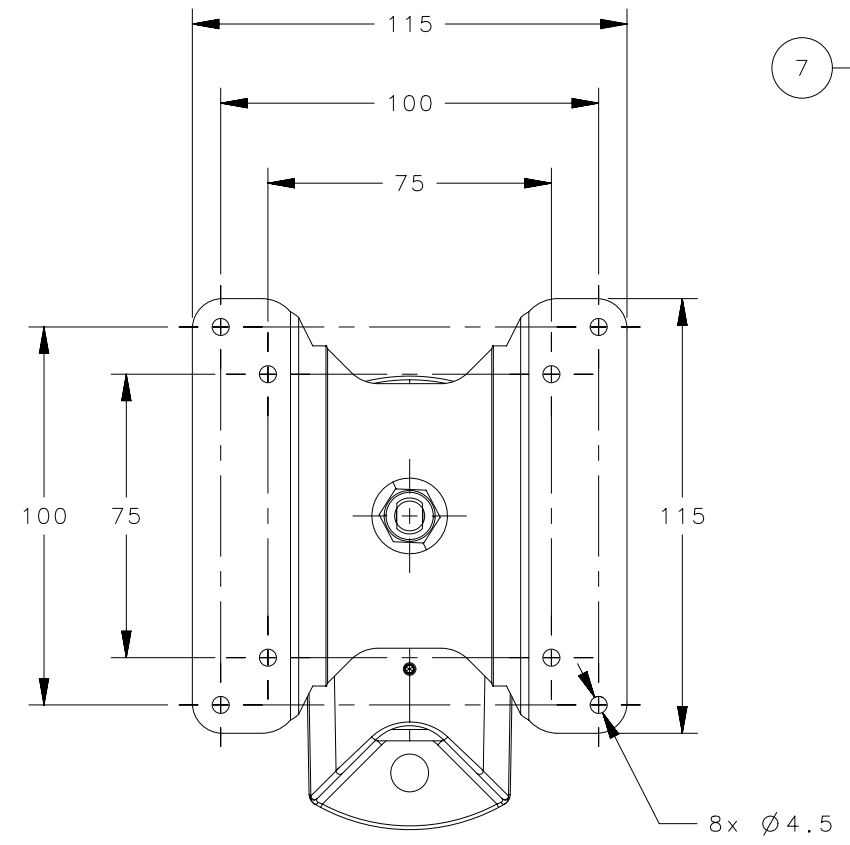
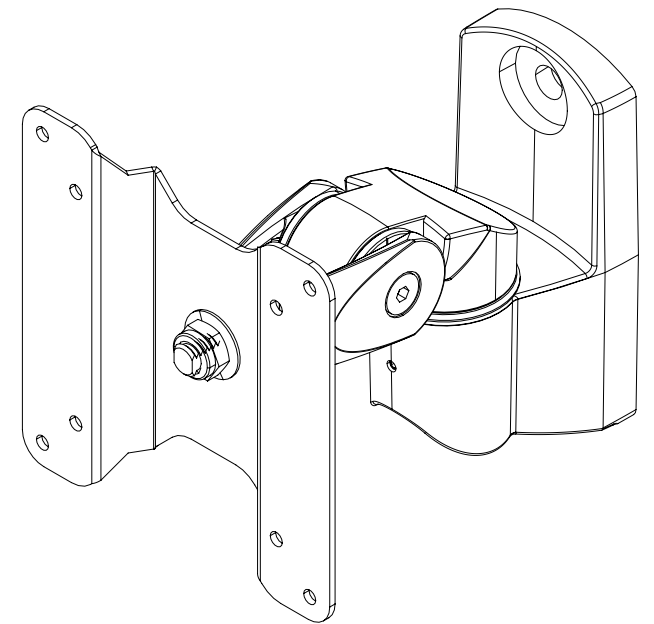
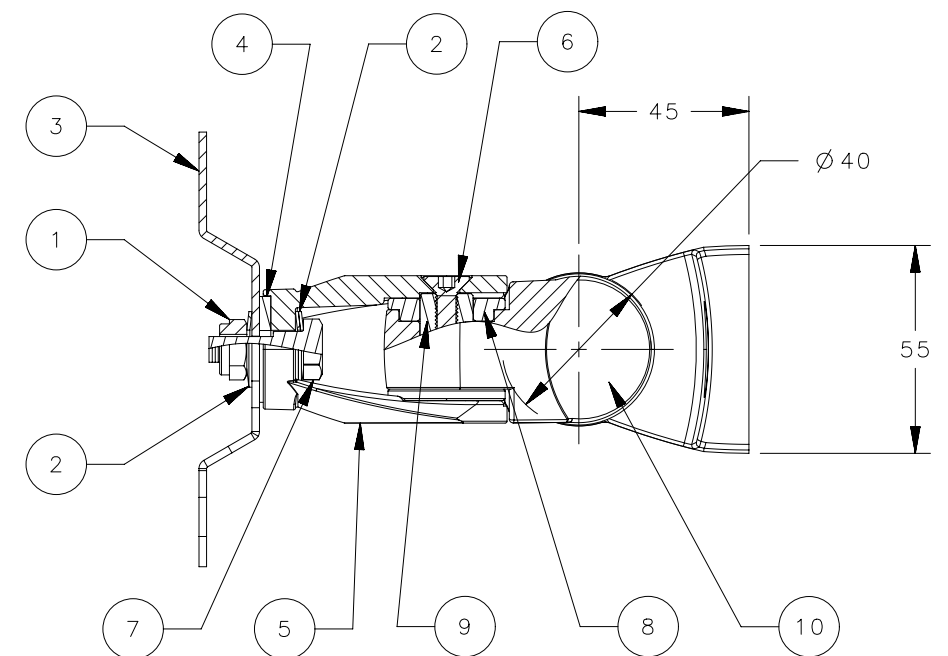

AV-B30-10K243-50	BLACK
AV-B30-10K243-70	SILVER
AV-B30-10K243-76	WHITE
SOUTHCO PART NUMBER	COLOUR

NOTES:

1. ALL EXTERIOR SURFACES CLASS C AND ALL INTERIOR SURFACES CLASS D PER SOUTHCO FINISH SPECIFICATION S-121.
2. PART SHOWN FULLY ASSEMBLED. SOME CUSTOMER ASSEMBLY MAY BE REQUIRED.
3. PART PACKAGED ONE PER BOX WITH INSTRUCTION FOR USE AND MOUNTING, ONE 4mm AND ONE 2mm ALLEN KEY.

CPB NUMBER	THIRD ANGLE PROJECTION
	MILLIMETERS [IN]
	TOLERANCES UNLESS OTHERWISE NOTED
	ALL DIMENSIONS WITHOUT TOLERANCES ARE FOR REFERENCE ONLY.
PROPRIETARY ITEM	PER ASME Y14.5M-1994
EXCEPT FOR USES EXPRESSLY GRANTED IN WRITING, INFORMATION DISCLOSED HEREON IS CONFIDENTIAL AND ALL RIGHTS, PATENT AND OTHERWISE, ARE RESERVED BY SOUTHCO, INC.	

southco[®]
CONNECT • CREATE • INNOVATE

DESCRIPTION
**HINGE & CONTROLLED MOTION DEVICE
WALL MOUNT, TILT, SWIVEL**

SIZE B	SYSTEM NX	DWG NO. J-AV-B30-10K
DRAWN BY SKB	DATE 20DEC2019	SCALE 1:2
		SHEET 1 OF 2

6

5

4

3

2

1

6

5

4

3

2

1

ITEM	PART	QTY	MATERIAL	FINISH	NOTES
20	INSTRUCTION FOR MOUNTING AND USE	1	N/A	N/A	NOT SHOWN
24	5mm ALLEN KEY	1	STEEL	BLACK OXIDE	LOCATED IN HARDWARE PACK
23	4mm ALLEN KEY	1	STEEL	BLACK OXIDE	LOCATED IN HARDWARE PACK
22	2mm ALLEN KEY	1	STEEL	BLACK OXIDE	LOCATED IN HARDWARE PACK
21	M4 x 10Lg SCREW	4	STEEL	ZINC PLATED	LOCATED IN HARDWARE PACK
20	M6 x 15Lg ROUND HEAD SCREW	1	STAINLESS STEEL	NATURAL	
19	SPRING WASHER	1	STEEL	ZINC PLATED	
18	WASHER	1	STAINLESS STEEL	NATURAL	
17	BUSHING	1	POM	NATURAL	
16	SCREW COVER	1	POLYCARBONATE	NATURAL	
15	M6 NYLON INSERT NUT	1	STEEL	ZINC PLATED	
14	M6 x 30Lg CAP HEAD SCREW	1	STEEL	ZINC PLATED	
13	M4 x 6Lg SET SCREW	1	STEEL	ZINC PLATED	
12	POLE MOUNT	1	DIE CAST ALUMINIUM	PAINTED	
11	BUSHING	1	POM	POM	
10	HOUSING	1	DIE CAST ALUMINIUM	PAINTED	
9	PIN	1	DIE CAST ALUMINIUM	PAINTED	
8	WASHER	2	COPPER	NATURAL	
7	3/8" HEX BOLT	1	ALLOY STEEL	ZINC PLATED	
6	M6 x 14Lg CSK HEAD SCREW	2	STEEL	PAINTED	
5	ADAPTER	1	DIE CAST ALUMINIUM	PAINTED	
4	Ø28 WASHER	1	NYLON	NATURAL	
3	MONITOR MOUNTING PLATE	1	STEEL	PAINTED	
2	Ø10 WASHER	3	STEEL	ZINC PLATED	
1	3/8" NYLON INSERT NUT	1	STEEL	ZINC PLATED	

REVISION HISTORY			
REV	DATE	BY	DESCRIPTION
B	26FEB2020	SKB/DMS	PRN: P2020-0230

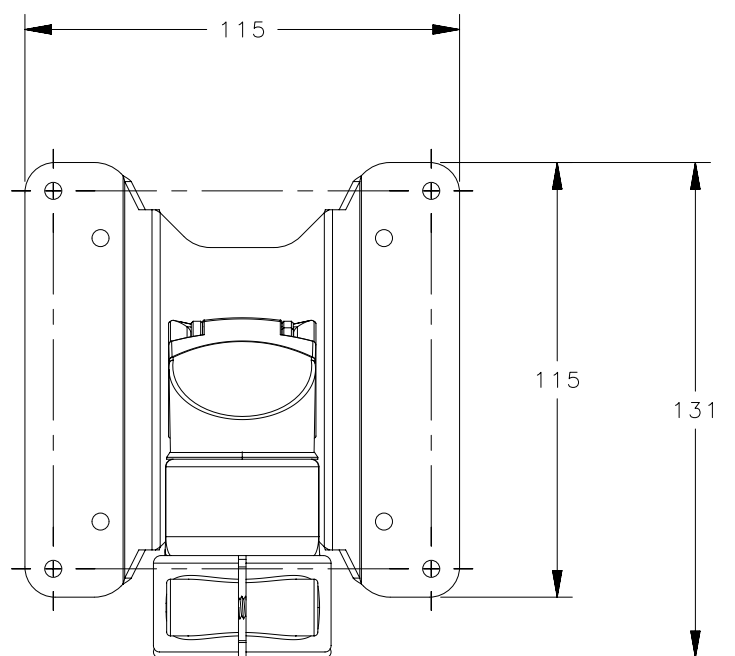
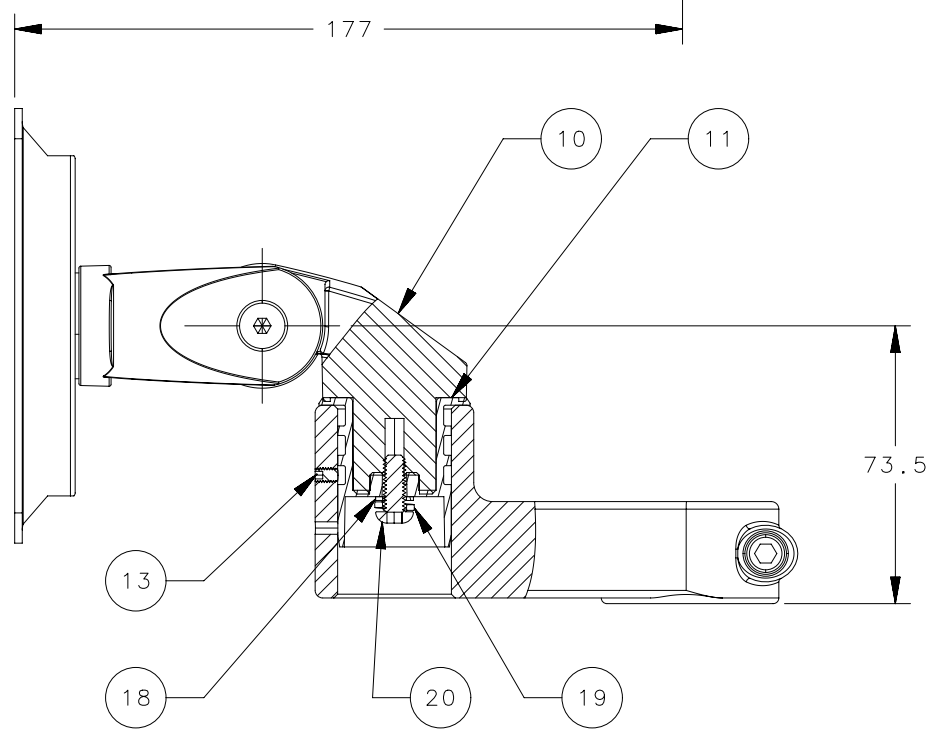
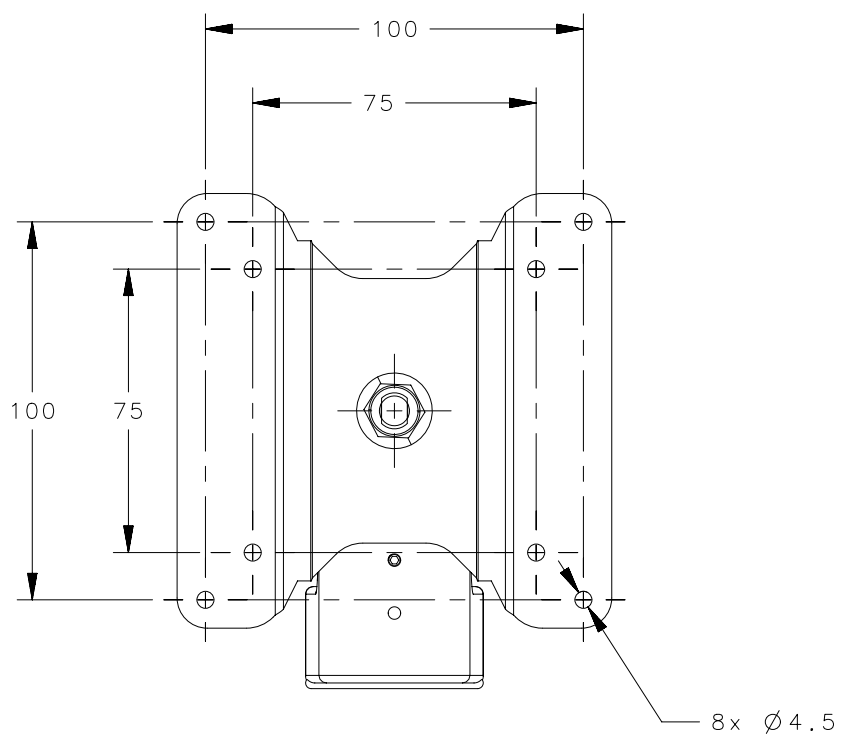
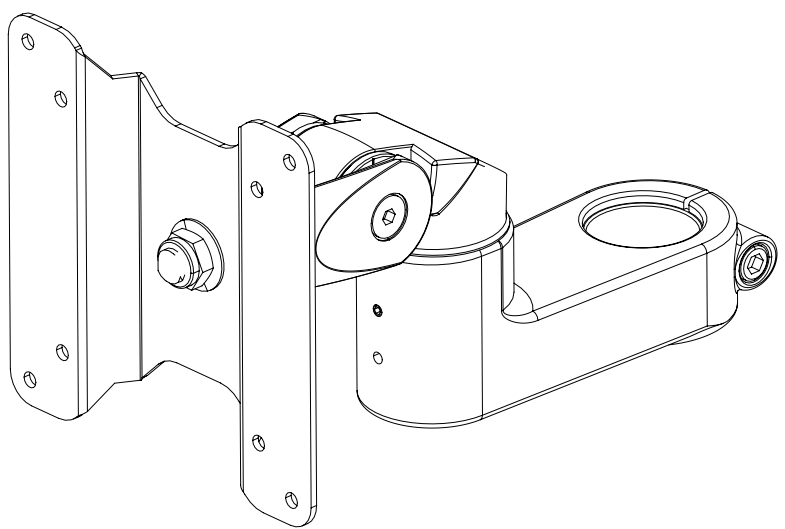
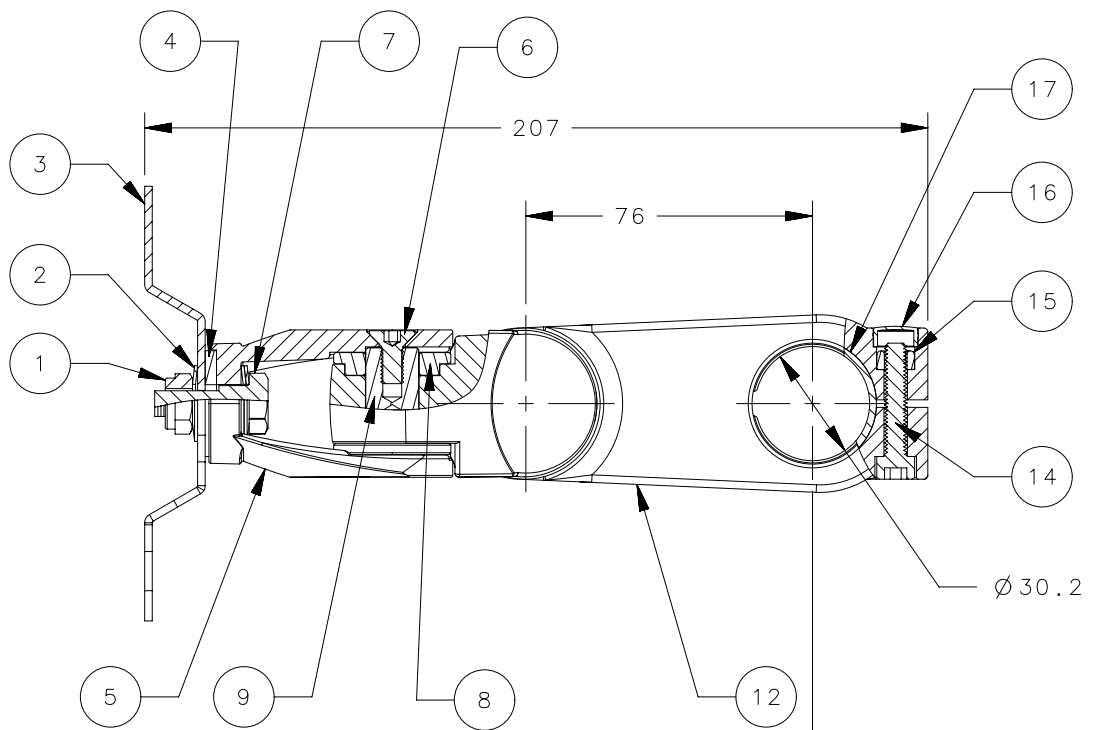

AV-B30-10K263-50	BLACK
AV-B30-10K263-70	SILVER
AV-B30-10K263-76	WHITE
SOUTHCO PART NUMBER	COLOUR

NOTES:

- ALL EXTERIOR SURFACES CLASS C AND ALL INTERIOR SURFACES CLASS D PER SOUTHCO FINISH SPECIFICATION S-121.
- PART SHOWN FULLY ASSEMBLED. SOME CUSTOMER ASSEMBLY MAY BE REQUIRED.
- PART PACKAGED ONE PER BOX WITH INSTRUCTION FOR USE AND MOUNTING, ONE 5mm, ONE 4mm AND ONE 2mm ALLEN KEY.
- FOR MATING POLE MOUNTS SEE PART NUMBERS AV-B30-40XC6 AND AV-B30-40XG6

CPB NUMBER	THIRD ANGLE PROJECTION		southco [®] CONNECT • CREATE • INNOVATE	
	MILLIMETERS [IN]			
	TOLERANCES UNLESS OTHERWISE NOTED		DESCRIPTION	HINGE & CONTROLLED MOTION DEVICE POLE MOUNT, TILT, SWIVEL
	ALL DIMENSIONS WITHOUT TOLERANCES ARE FOR REFERENCE ONLY.	SIZE	SYSTEM	DWG NO.
PROPRIETARY ITEM <small>EXCEPT FOR USES EXPRESSLY GRANTED IN WRITING, INFORMATION DISCLOSED HEREON IS CONFIDENTIAL AND ALL RIGHTS, PATENT AND OTHERWISE, ARE RESERVED BY SOUTHCO, INC.</small>	PER ASME Y14.5M-1994	B	NX	J-AV-B30-10K
		DRAWN BY	DATE	SCALE
		SKB	20DEC2019	1:1
				SHEET 2 OF 2

6

5

4

3

2

1