

6

5

4

3

2

1

REVISION HISTORY			
REV	DATE	BY	DESCRIPTION
B	26FEB2020	SKB/DMS	PRN: P2020-0230

NOTES:

1. ALL EXTERIOR SURFACES CLASS C AND ALL INTERIOR SURFACES CLASS D PER SOUTHCO FINISH SPECIFICATION S-121.
2. PART SHOWN FULLY ASSEMBLED. SOME CUSTOMER ASSEMBLY MAY BE REQUIRED.
3. PART PACKAGED ONE PER BOX WITH INSTRUCTION FOR USE AND MOUNTING, ONE 4mm AND ONE 2mm ALLEN KEY.

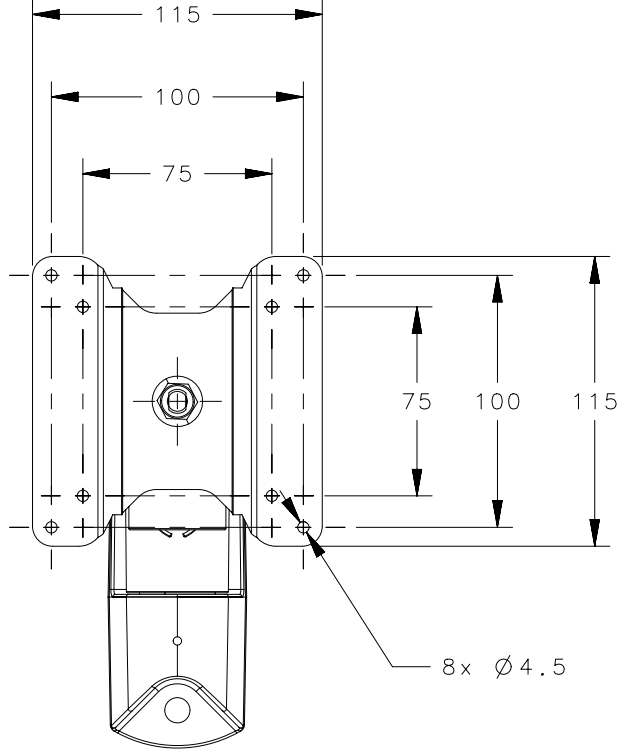
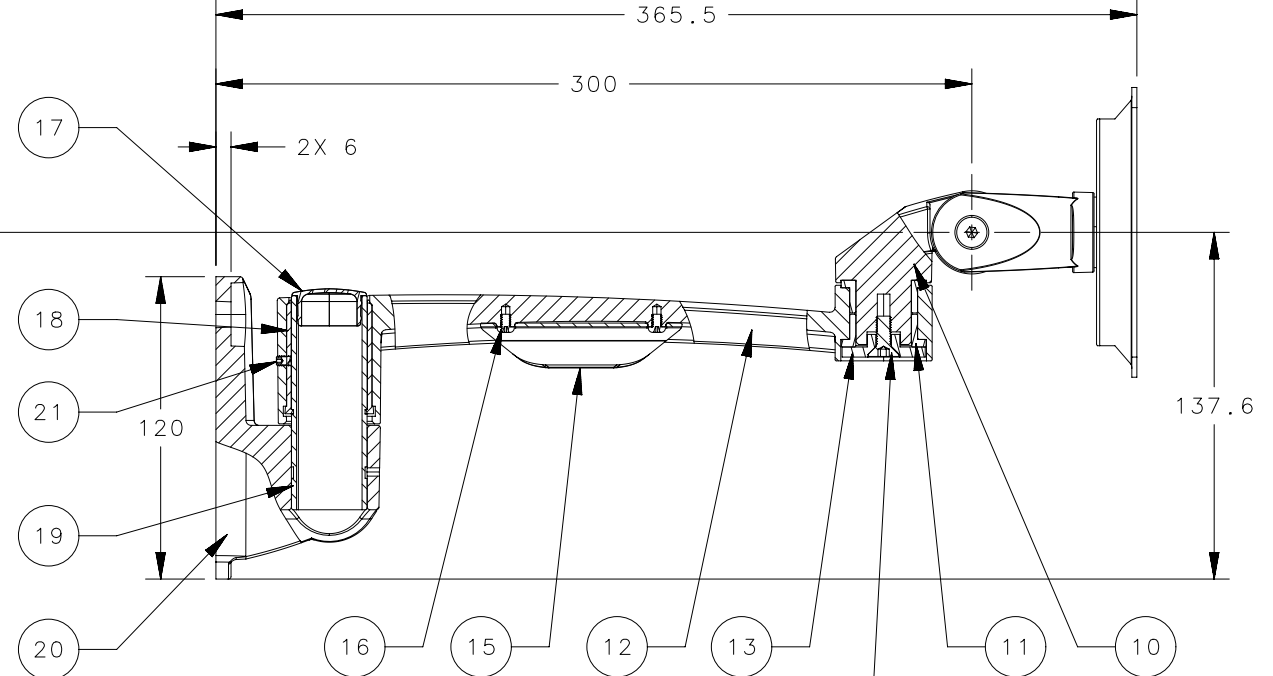
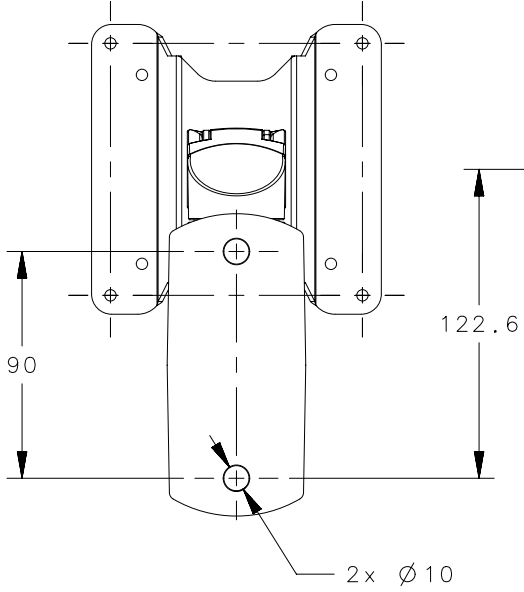
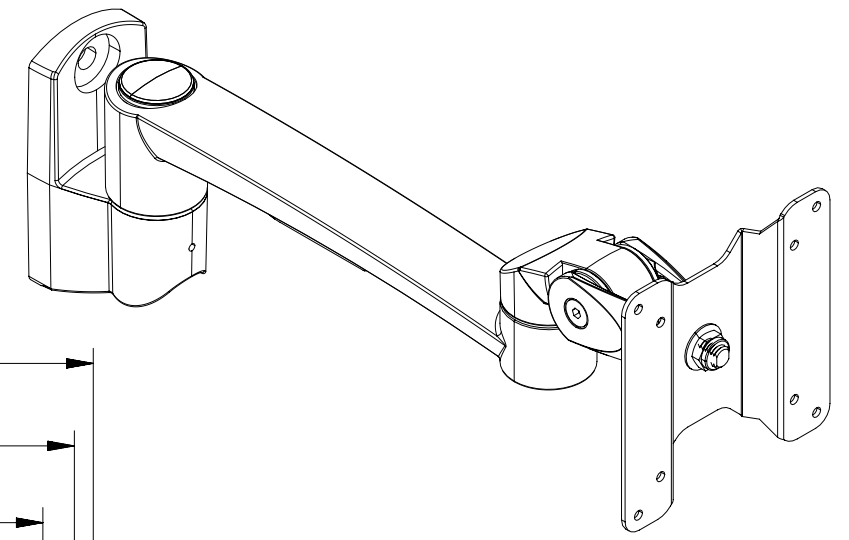
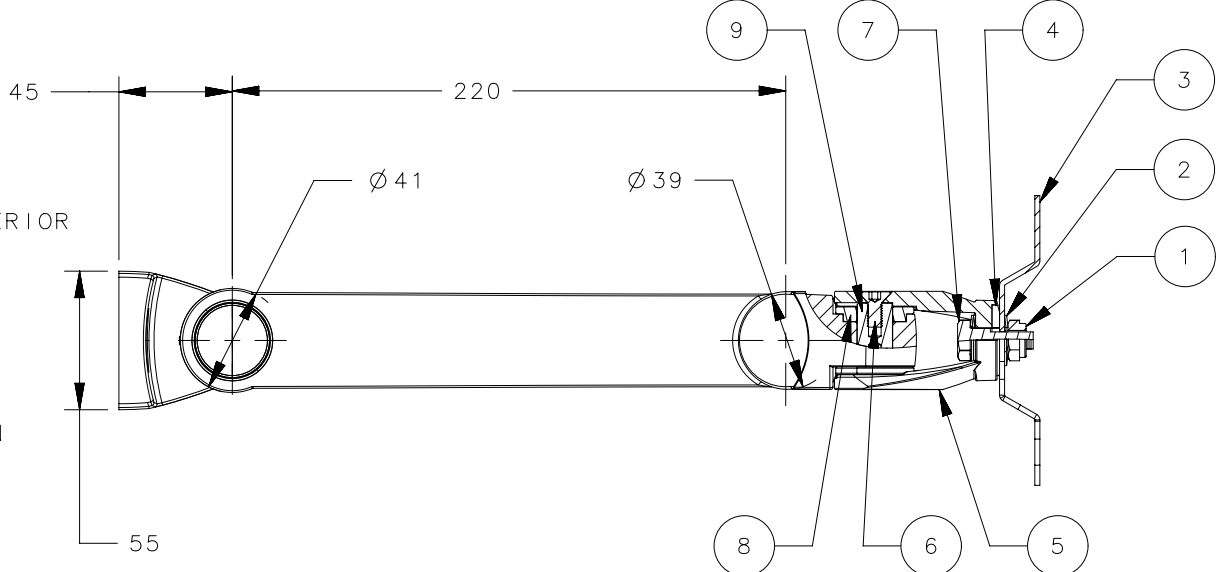

ITEM	PART	QTY	MATERIAL	FINISH	NOTES
25	INSTRUCTION FOR MOUNTING AND USE	1	N/A	N/A	NOT SHOWN
24	4mm ALLEN KEY	1	STEEL	BLACK OXIDE	LOCATED IN HARDWARE PACK
23	2mm ALLEN KEY	1	STEEL	BLACK OXIDE	LOCATED IN HARDWARE PACK
22	M4 x 10Lg SCREW	4	STEEL	ZINC PLATED	LOCATED IN HARDWARE PACK
21	M4 x 6Lg SET SCREW	2	STEEL	ZINC PLATED	
20	WALL MOUNT	1	DIE CAST ALUMINIUM	PAINTED	
19	CONNECTING SLEEVE	1	STEEL	ZINC PLATED	
18	LONG BUSHING	1	POM	NATURAL	
17	END CAP	1	POLYPROPYLENE	NATURAL	
16	M4 x 5Lg ROUND HEAD SCREW	2	STEEL	ZINC PLATED	
15	CABLE MANAGEMENT	1	POLYPROPYLENE	NATURAL	
14	M6 x 20Lg CSK HEAD SCREW	1	STEEL	ZINC PLATED	
13	CAP	1	DIE CAST ZINC	PAINTED	
12	LONG ARM	1	DIE CAST ALUMINIUM	PAINTED	
11	BUSHING	2	POM	POM	
10	HOUSING	1	DIE CAST ALUMINIUM	PAINTED	
9	PIN	1	DIE CAST ALUMINIUM	PAINTED	
8	WASHER	2	COPPER	NATURAL	
7	3/8" HEX BOLT	1	ALLOY STEEL	ZINC PLATED	
6	M6 x 14Lg CSK HEAD SCREW	2	STEEL	PAINTED	
5	ADAPTER	1	DIE CAST ALUMINIUM	PAINTED	
4	Ø28 WASHER	1	NYLON	NATURAL	
3	MONITOR MOUNTING PLATE	1	STEEL	PAINTED	
2	Ø10 WASHER	3	STEEL	ZINC PLATED	
1	3/8" NYLON INSERT NUT	1	STEEL	ZINC PLATED	

AV-B30-23A243-50	BLACK
AV-B30-23A243-70	SILVER
AV-B30-23A243-76	WHITE
SOUTHCO PART NUMBER	COLOUR

CPB NUMBER	THIRD ANGLE PROJECTION									
	MILLIMETERS [IN]									
	TOLERANCES UNLESS OTHERWISE NOTED	<b>HINGE &amp; CONTROLLED MOTION DEVICE</b> <b>WALL MOUNT, SINGLE ARM</b>								
	ALL DIMENSIONS WITHOUT TOLERANCES ARE FOR REFERENCE ONLY.									
PROPRIETARY ITEM EXCEPT FOR USES EXPRESSLY GRANTED IN WRITING, INFORMATION DISCLOSED HEREON IS CONFIDENTIAL AND ALL RIGHTS, PATENT AND OTHERWISE, ARE RESERVED BY SOUTHCO, INC.	PER ASME Y14.5M-1994	<table border="1"> <tr> <td>DESCRIPTION</td> <td>SIZE</td> <td>SYSTEM</td> <td>DWG NO.</td> </tr> <tr> <td></td> <td>B</td> <td>NX</td> <td>J-AV-B30-23A</td> </tr> </table>	DESCRIPTION	SIZE	SYSTEM	DWG NO.		B	NX	J-AV-B30-23A
DESCRIPTION	SIZE	SYSTEM	DWG NO.							
	B	NX	J-AV-B30-23A							
		<table border="1"> <tr> <td>DRAWN BY</td> <td>DATE</td> <td>SCALE</td> <td>SHEET</td> </tr> <tr> <td>SKB</td> <td>20DEC2019</td> <td>1:3</td> <td>1 OF 2</td> </tr> </table>	DRAWN BY	DATE	SCALE	SHEET	SKB	20DEC2019	1:3	1 OF 2
DRAWN BY	DATE	SCALE	SHEET							
SKB	20DEC2019	1:3	1 OF 2							

6

5

4

3

2

1

REVISION HISTORY			
REV	DATE	BY	DESCRIPTION
B	26FEB2020	SKB/DMS	PRN: P2020-0230

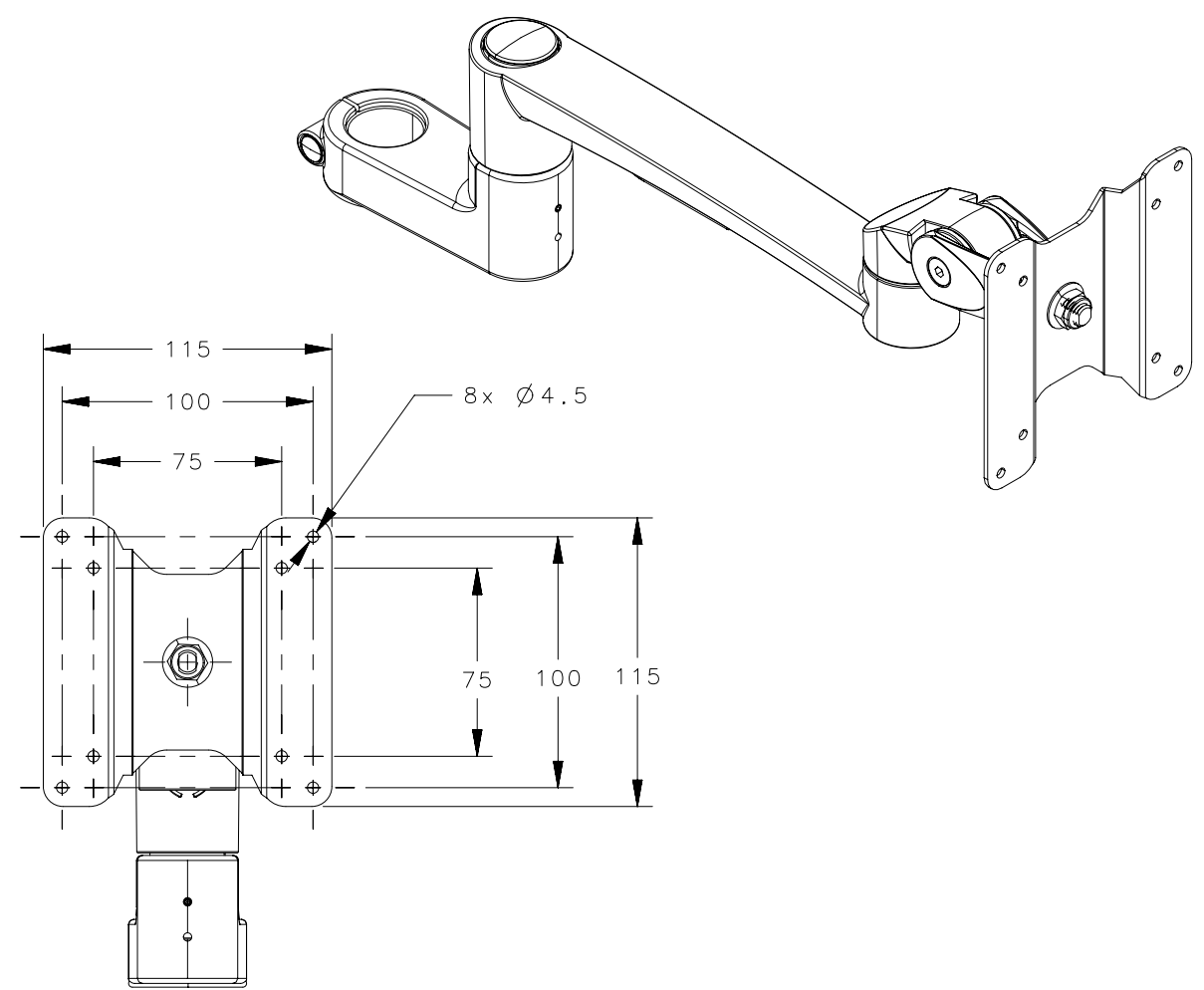
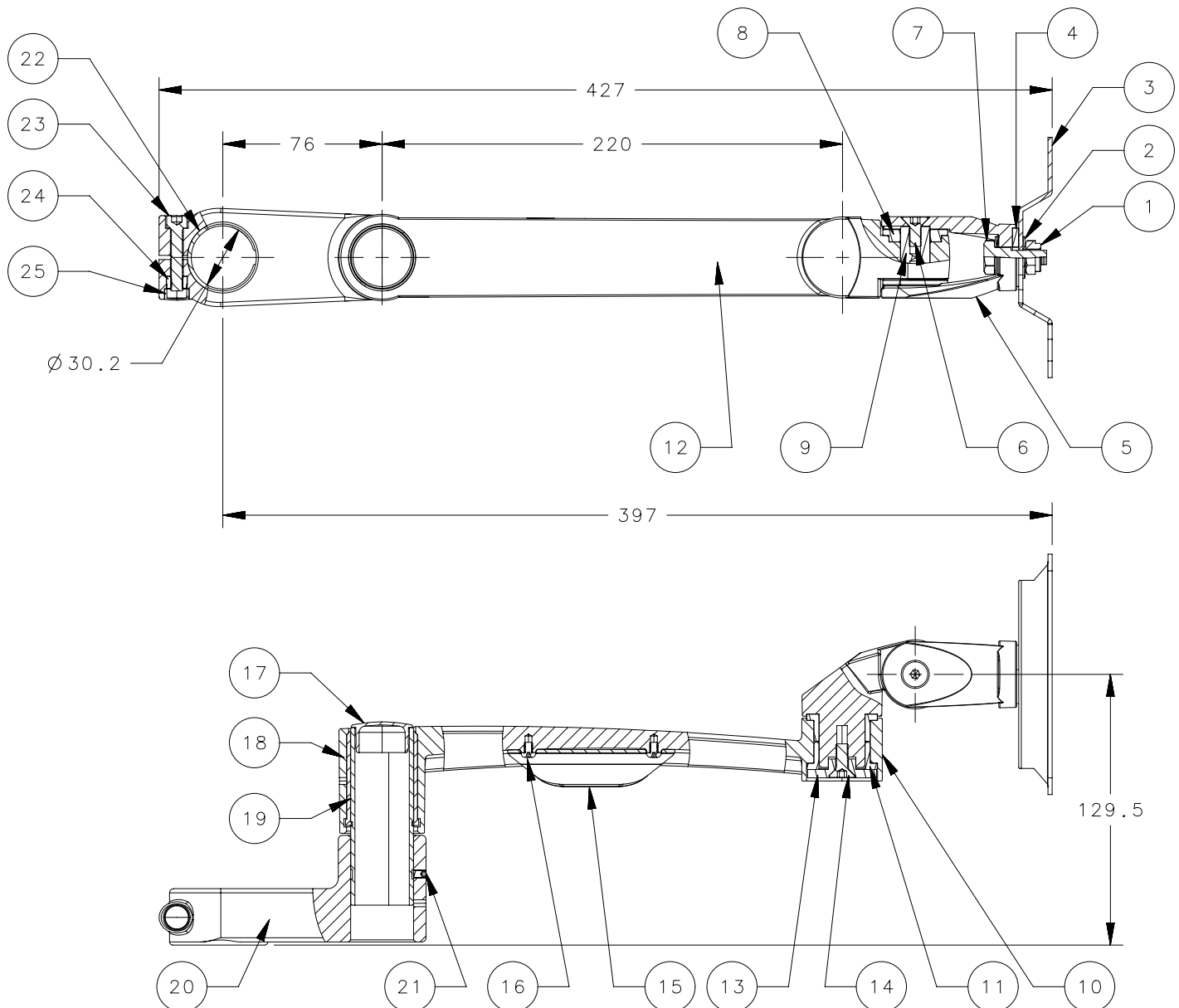

ITEM	PART	QTY	MATERIAL	FINISH	NOTES
30	INSTRUCTION FOR MOUNTING AND USE	1	N/A	N/A	NOT SHOWN
29	5mm ALLEN KEY	1	STEEL	BLACK OXIDE	LOCATED IN HARDWARE PACK
28	4mm ALLEN KEY	1	STEEL	BLACK OXIDE	LOCATED IN HARDWARE PACK
27	2mm ALLEN KEY	1	STEEL	BLACK OXIDE	LOCATED IN HARDWARE PACK
26	M4 x 10Lg SCREW	4	STEEL	ZINC PLATED	LOCATED IN HARDWARE PACK
25	NUT CAP	1	POLYCARBONATE	NATURAL	
24	M6 NYLON INSERT NUT	1	STEEL	ZINC PLATED	
23	M6 x 30Lg CAP HEAD SCREW	1	STEEL	ZINC PLATED	
22	BUSHING	1	POM	NATURAL	
21	M4 x 6Lg SET SCREW	2	STEEL	ZINC PLATED	
20	POLE MOUNT	1	DIE CAST ALUMINIUM	PAINTED	
19	CONNECTING SLEEVE	1	STEEL	ZINC PLATED	
18	LONG BUSHING	1	POM	NATURAL	
17	END CAP	1	POLYPROPYLENE	NATURAL	
16	M4 x 5Lg ROUND HEAD SCREW	2	STEEL	ZINC PLATED	
15	CABLE MANAGEMENT	1	POLYPROPYLENE	NATURAL	
14	M6 x 20Lg CSK HEAD SCREW	1	STEEL	ZINC PLATED	
13	CAP	1	DIE CAST ZINC	PAINTED	
12	LONG ARM	1	ALUMINIUM	PAINTED	
11	BUSHING	2	POM	POM	
10	HOUSING	1	DIE CAST ALUMINIUM	PAINTED	
9	PIN	1	DIE CAST ALUMINIUM	PAINTED	
8	WASHER	2	COPPER	NATURAL	
7	3/8" HEX BOLT	1	ALLOY STEEL	ZINC PLATED	
6	M6 x 14Lg CSK HEAD SCREW	2	STEEL	PAINTED	
5	ADAPTER	1	DIE CAST ALUMINIUM	PAINTED	
4	Ø28 WASHER	1	NYLON	NATURAL	
3	MONITOR MOUNTING PLATE	1	STEEL	PAINTED	
2	Ø10 WASHER	3	STEEL	ZINC PLATED	
1	3/8" NYLON INSERT NUT	1	STEEL	ZINC PLATED	

NOTES:

1. ALL EXTERIOR SURFACES CLASS C AND ALL INTERIOR SURFACES CLASS D PER SOUTHCO FINISH SPECIFICATION S-121.
2. PART SHOWN FULLY ASSEMBLED. SOME CUSTOMER ASSEMBLY MAY BE REQUIRED.
3. PART PACKAGED ONE PER BOX WITH INSTRUCTION FOR USE AND MOUNTING, ONE 5mm, ONE 4mm AND ONE 2mm ALLEN KEY.
4. FOR MATING POLE MOUNTS SEE PART NUMBERS AV-B30-40XC6 AND AV-B30-40XG6

AV-B30-23A263-50	BLACK
AV-B30-23A263-70	SILVER
AV-B30-23A263-76	WHITE
SOUTHCO PART NUMBER	COLOUR

CPB NUMBER	THIRD ANGLE PROJECTION		<b>southco</b> <sup>®</sup> CONNECT • CREATE • INNOVATE	
	MILLIMETERS [IN]			
SURFACE AREA	TOLERANCES UNLESS OTHERWISE NOTED	<small>DESCRIPTION</small> HINGE & CONTROLLED MOTION DEVICE POLE MOUNT, SINGLE ARM	SIZE	SYSTEM
VOLUME	ALL DIMENSIONS WITHOUT TOLERANCES ARE FOR REFERENCE ONLY.		B	NX
PROPRIETARY ITEM	PER ASME Y14.5M-1994	DWG NO.	J-AV-B30-23A	
<small>EXCEPT FOR USES EXPRESSLY GRANTED IN WRITING, INFORMATION DISCLOSED HEREON IS CONFIDENTIAL AND ALL RIGHTS, PATENT AND OTHERWISE, ARE RESERVED BY SOUTHCO, INC.</small>	DRAWN BY SKB	DATE 20DEC2019	SCALE 1:1	SHEET 2 OF 2