

REVISION HISTORY			
REV	DATE	BY	DESCRIPTION
C	01MAY2020	GEA/DMS	PRN: P2019-3080

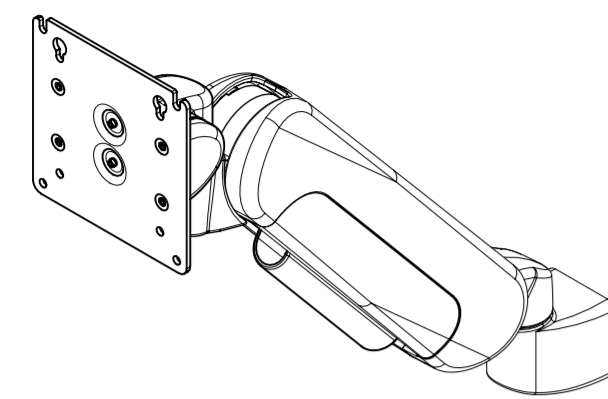

DISPLAY SWIVEL  
±90° FROM  
POSITION SHOWN

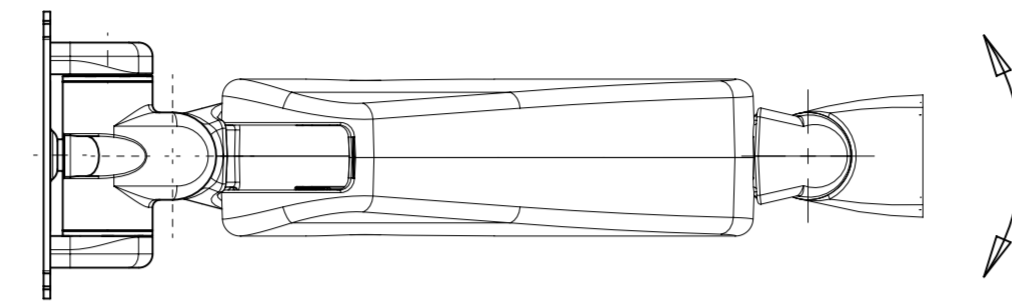

ARM PIVOT  
±90° FROM  
POSITION SHOWN

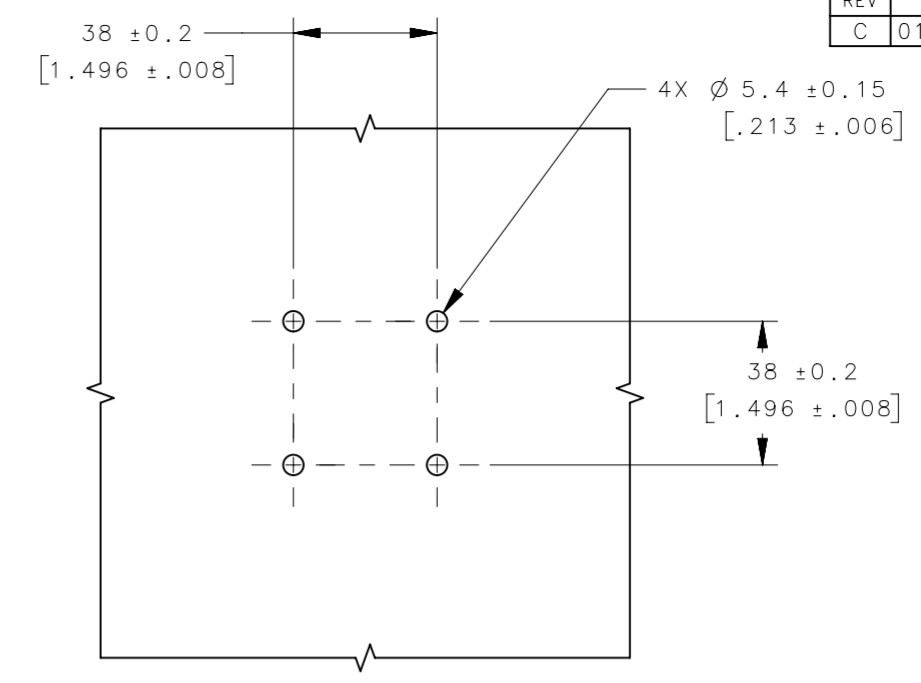

### MOUNTING PANEL PREPARATION

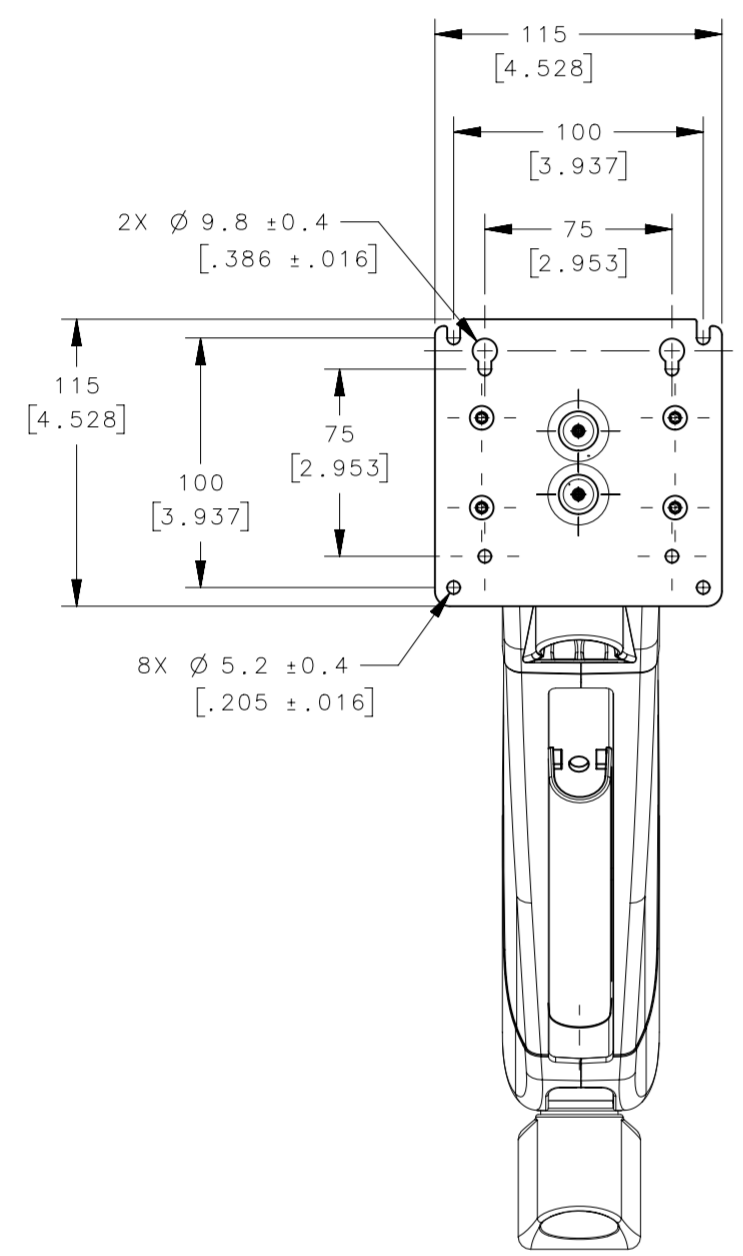

2.67 [0.105]  
3.0 [0.118] MAXIMUM  
WHEN POWDER COATED

DISPLAY TILT  
+35° FORWARD  
-20° REVERSE  
FROM POSITION  
SHOWN

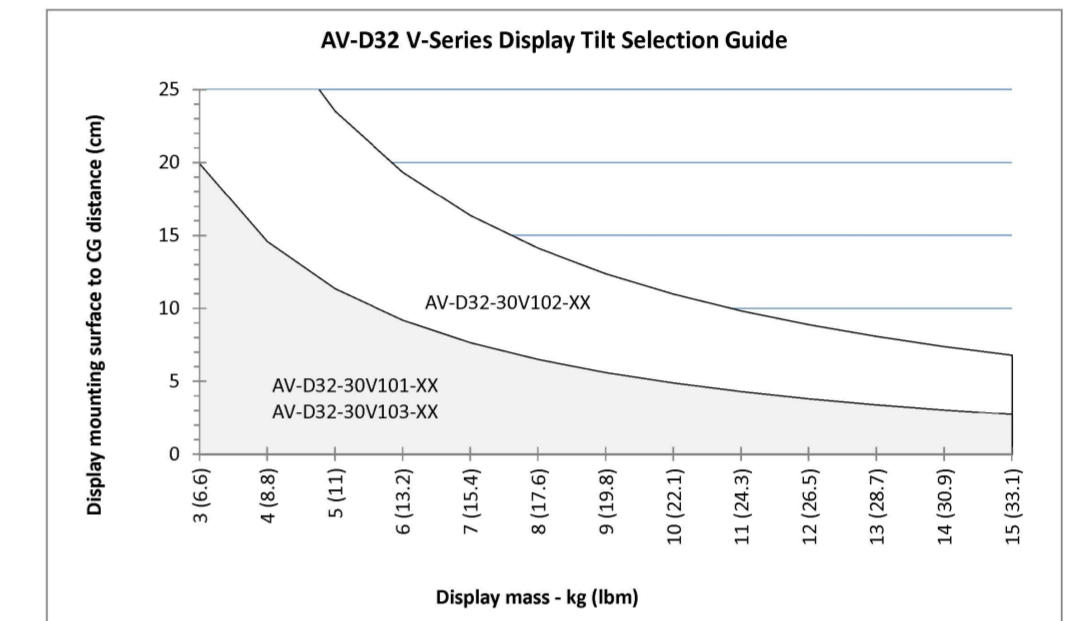
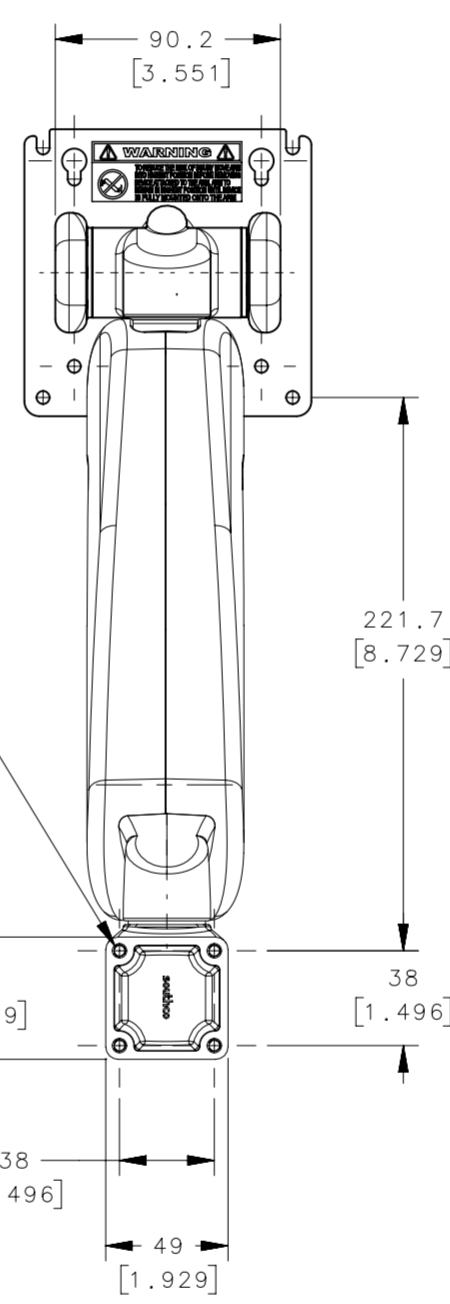
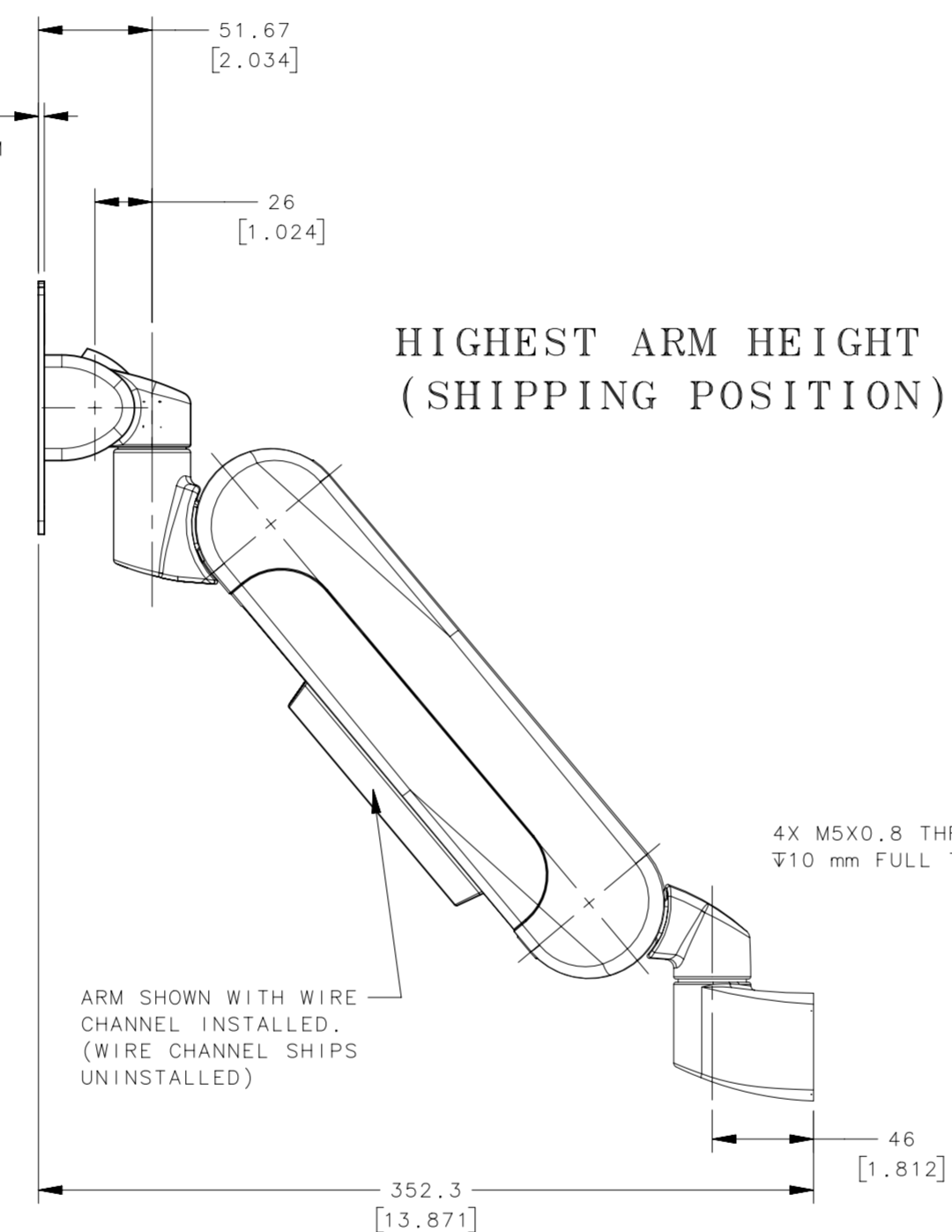

- NOTES:
- FINISH PER SOUTHCO COSMETIC SPECIFICATION S-121. ALL POWDER COATED EXTERIOR VISIBLE SURFACES CLASS C AND PLASTIC COVERS CLASS B.
  - TILT TORQUE MEASURED WITH DISPLAY MOUNTING PLATE IN THE VERTICAL 0° ± 5° POSITION WHEN TILTING IN THE REVERSE DIRECTION. THE TILT TORQUE VARIES WITH THE COUNTERBALANCE (WHEN EQUIPPED) IN THE FORWARD AND REVERSE DIRECTIONS.
  - THE DISPLAY MOUNTING PLATE TO TILT HOUSING ANGULAR FREE PLAY TO BE 1.5° MAXIMUM.
  - THE ARM IS ADJUSTABLE TO SUPPORT DISPLAYS OF WEIGHT WITHIN RANGE SPECIFIED IN THE TABLE BELOW. THE DISPLAY IS ADJUSTED BY USING A 5 mm HEX KEY IN THE TOP OF THE LOWER HOUSING. THIS IS ACCESSED BY LOWERING THE ARM POSITION WITH THE DISPLAY ATTACHED TO JUST BELOW THE HORIZONTAL POSITION. THE ADJUSTMENT SCREW IS TURNED CLOCKWISE FOR A LIGHTER DISPLAY AND COUNTERCLOCKWISE FOR HEAVIER DISPLAYS. THE ARM SHIPS WITH THE ADJUSTMENT FOR THE HEAVIEST DISPLAY. (SEE SHEET 2 OF 4)
  - MATERIALS AND FINISHES:  
 ADAPTERS: DIE CAST ALUMINUM ANODIZED AND POWDER COATED  
 ARM, TILT HOUSING UPPER KNUCKLE AND LOWER KNUCKLE, AND ARM ADAPTER: DIE CAST ALUMINUM, POWDER COATED  
 TILT SLEEVE, THRUST WASHER AND SHELL: ACETAL, BLACK  
 COILED PIN: STEEL, PHOSPHATE COATED  
 TILT SHAFT, TORQUE ELEMENTS AND STOP WASHER: STEEL, NATURAL FINISH  
 TORSION SPRING: CARBON STEEL, NICKEL PLATED (WHEN EQUIPPED)  
 DISPLAY SCREWS AND RETAINERS: STEEL, BLACK OXIDE  
 DISPLAY STOPS: POLYETHYLENE, WHITE  
 LINK BUSHING AND STRUT ADJUST BUSHING: BRASS, NATURAL  
 LINK FLANGED SLEEVE: STEEL, TEFLON COATED  
 STRUT PIN: STAINLESS STEEL  
 STRUT ADJUST ADAPTER: ZINC, NICKEL PLATED  
 GAS SPRING: STEEL AND ZINC, PAINTED  
 ARM LINKS, STRUT BALL MOUNT: STEEL, ZINC PLATED  
 ARM PIVOT SHAFTS: STAINLESS STEEL AND NYLON  
 LINK PINS: STEEL, NICKEL PLATED  
 ARM COVERS AND WIRE CHANNEL: PC/ABS  
 INSIDE ARM COVERS: POLYAMIDE (NYLON)  
 LUBRICANT: HYDROCARBON BASE

**WARNING:**  
TO REDUCE THE RISK OF INJURY MOVE ARM INTO HIGHEST POSITION BEFORE REMOVING DEVICE ATTACHED TO ARM. ARM TO REMAIN IN HIGHEST POSITION UNTIL DEVICE IS FULLY MOUNTED INTO THE ARM.

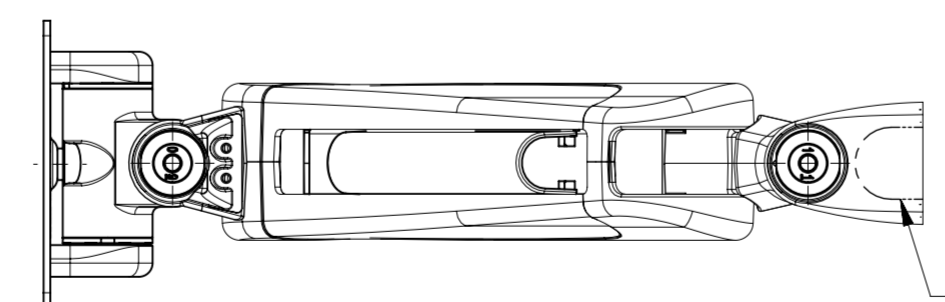

ASSEMBLIES CAN BE ORDERED WITH AN OPTIONAL WIRE NOTCH IN HOUSING FOR EASIER WIRE ROUTING

PART NUMBER	PART NUMBER (WITH WIRE CUT-OUT) *	REVERSE TILT TORQUE N*m (lbf*in)	FORWARD TILT TORQUE N*m (lbf*in)	DISPLAY SWIVEL SYMMETRIC TORQUE N*m (lbf*in)	SYMMETRIC TORQUE TO MOVE ARM ASSEMBLY N*m (lbf*in)	RECOMMENDED DISPLAY WEIGHT RANGE	COLOR
AV-D32-30V101-50	AV-D32-30V111-50	7.9 (70)	1.13 (10)	4.29 N*m (38 lbf*in) NOMINAL / 2.17 N*m (19.2 lbf*in) MINIMUM	6.0 N*m (53.1 lbf*in) NOMINAL / 4.2 N*m (37.1 lbf*in) MINIMUM	2 To 7 kg (4.4 TO 15.4 lbm)	BLACK
AV-D32-30V101-76	AV-D32-30V111-76					5 TO 10 Kg (11 TO 22 lbm)	OFFICE WHITE
AV-D32-30V102-50	AV-D32-30V112-50	15.4 (136)	2.26 (20)	4.29 N*m (38 lbf*in) NOMINAL / 2.17 N*m (19.2 lbf*in) MINIMUM	6.0 N*m (53.1 lbf*in) NOMINAL / 4.2 N*m (37.1 lbf*in) MINIMUM	2 To 7 kg (4.4 TO 15.4 lbm)	BLACK
AV-D32-30V102-76	AV-D32-30V112-76					5 TO 10 Kg (11 TO 22 lbm)	OFFICE WHITE
AV-D32-30V103-50	AV-D32-30V113-50	8.6 (76)	6.0 (53)	4.29 N*m (38 lbf*in) NOMINAL / 2.17 N*m (19.2 lbf*in) MINIMUM	6.0 N*m (53.1 lbf*in) NOMINAL / 4.2 N*m (37.1 lbf*in) MINIMUM	2 To 7 kg (4.4 TO 15.4 lbm)	BLACK
AV-D32-30V103-76	AV-D32-30V113-76					5 TO 10 Kg (11 TO 22 lbm)	OFFICE WHITE

\* ASSEMBLIES CAN BE ORDERED WITH AN OPTIONAL WIRE NOTCH IN HOUSING FOR EASIER WIRE ROUTING. SEE SHEET 2.

THIRD ANGLE PROJECTION	
MILLIMETERS [IN]	
SURFACE AREA mm <sup>2</sup>	DESCRIPTION <b>HINGE &amp; CONTROLLED MOTION DEVICE (STANDARD LIFT ARM, WALL MOUNT)</b>
VOLUME mm <sup>3</sup>	
PROPRIETARY ITEM EXCEPT FOR USES EXPRESSLY GRANTED IN WRITING. INFORMATION DISCLOSED HEREON IS CONFIDENTIAL AND ALL RIGHTS, PATENT AND OTHERWISE, ARE RESERVED BY SOUTHCO, INC.	ALL DIMENSIONS WITHOUT TOLERANCES ARE FOR REFERENCE ONLY. TOLERANCES UNLESS OTHERWISE NOTED: SIZE SYSTEM: A2 NX DWG NO.: J-AV-D32-30V101 PER ASME Y14.5M-1994 DRAWN BY: GEA DATE: 01FEB2015 SCALE: 1:1 SHEET: 1 OF 4

8

7

6

5

4

3

2

1

REVISION HISTORY			
REV	DATE	BY	DESCRIPTION
C	01MAY2020	GEA/DMS	PRN: P2019-3080

### ARM DISPLAY WEIGHT ADJUSTMENT

(ARM TO BE ADJUSTED WITH DISPLAY MOUNTED)

DISPLAY WEIGHT ADJUSTMENT  
5mm HEX RECESS FOR HEX KEY

- TURN SCREW CW (CLOCKWISE) TO  
DECREASE TENSION FOR A LIGHTER DISPLAY

+ TURN SCREW CCW (COUNTERCLOCKWISE) TO  
INCREASE TENSION FOR A HEAVIER DISPLAY

(NOTE: ADJUSTMENT IS EASIER IF ARM IS POSITIONED  
BELOW HORIZONTAL WITH THE DISPLAY ATTACHED)

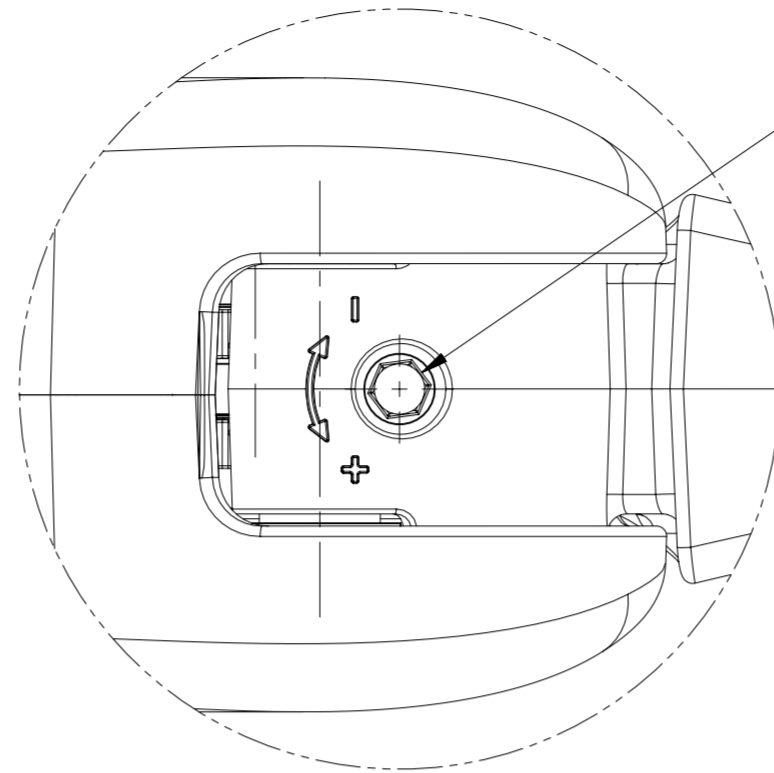

DETAIL A  
SCALE 4:3

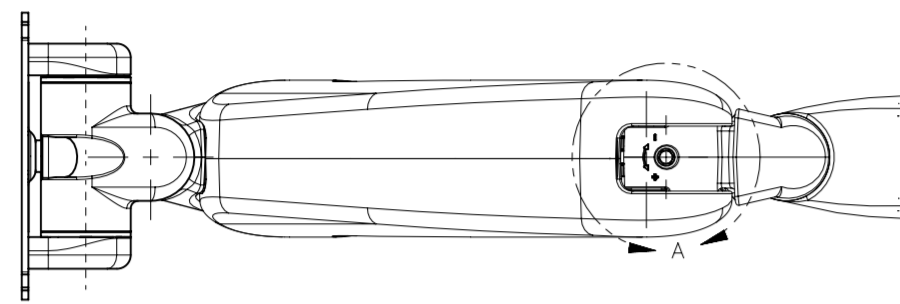

LOWEST ARM POSITION

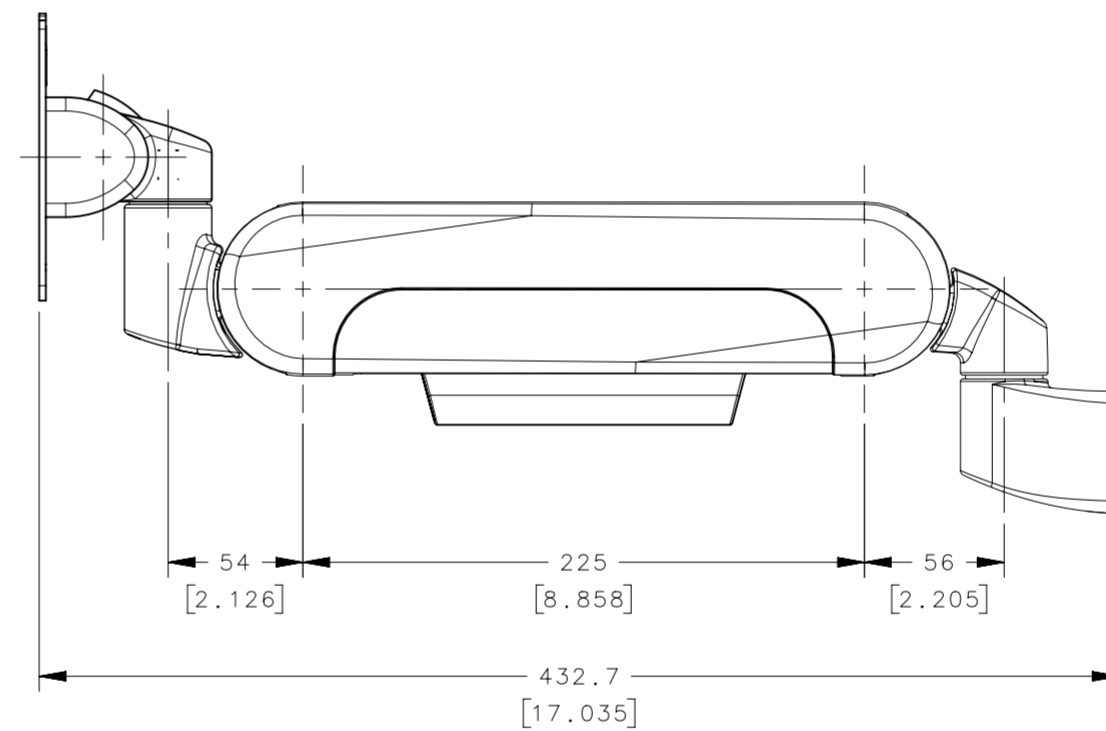

HORIZONTAL ARM POSITION

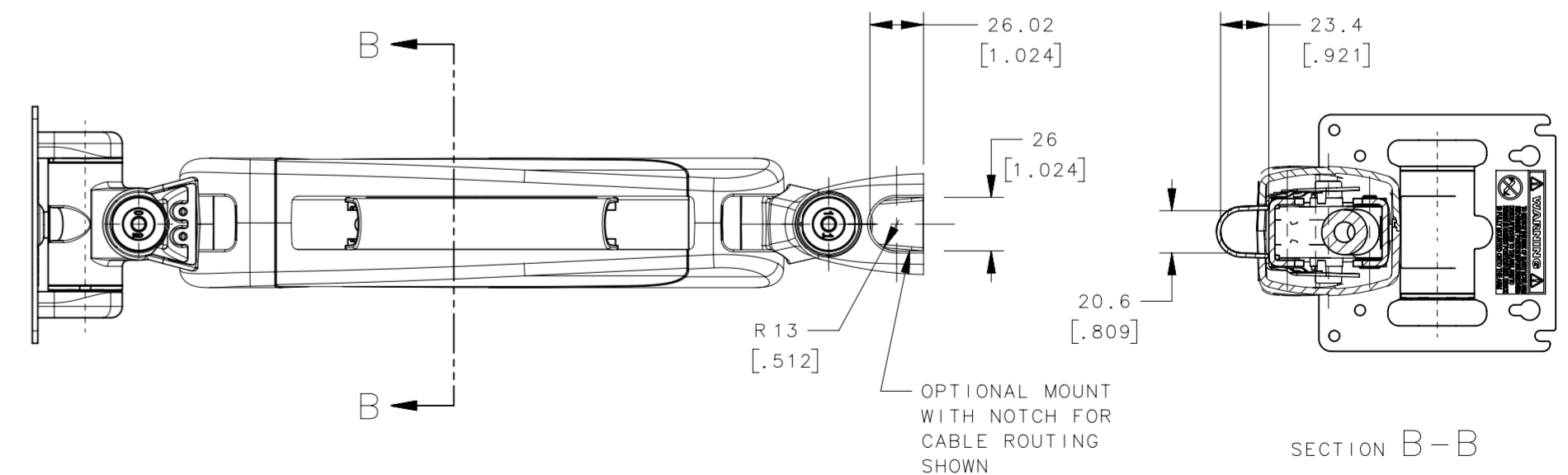
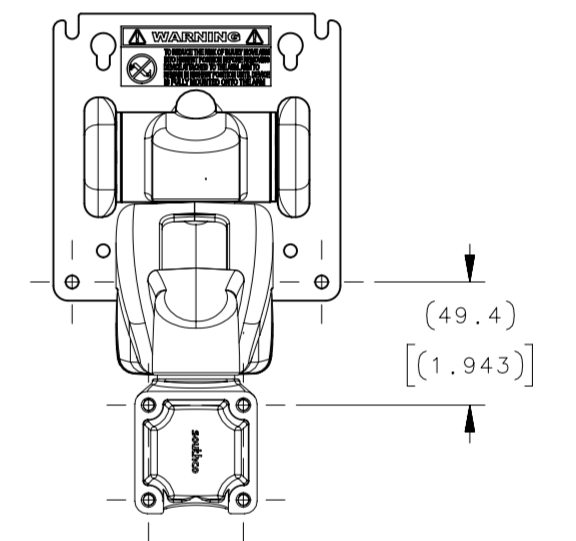
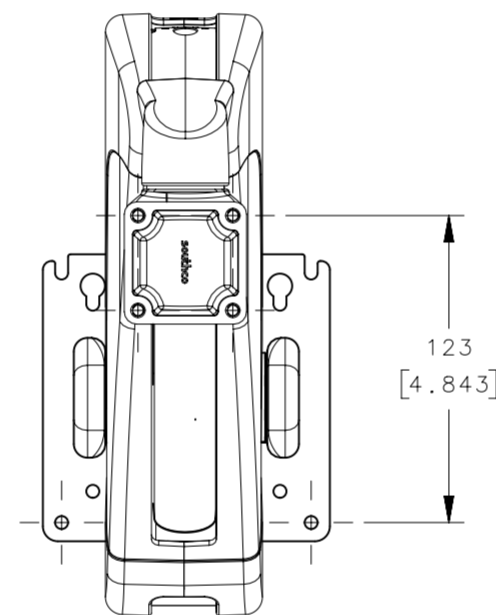
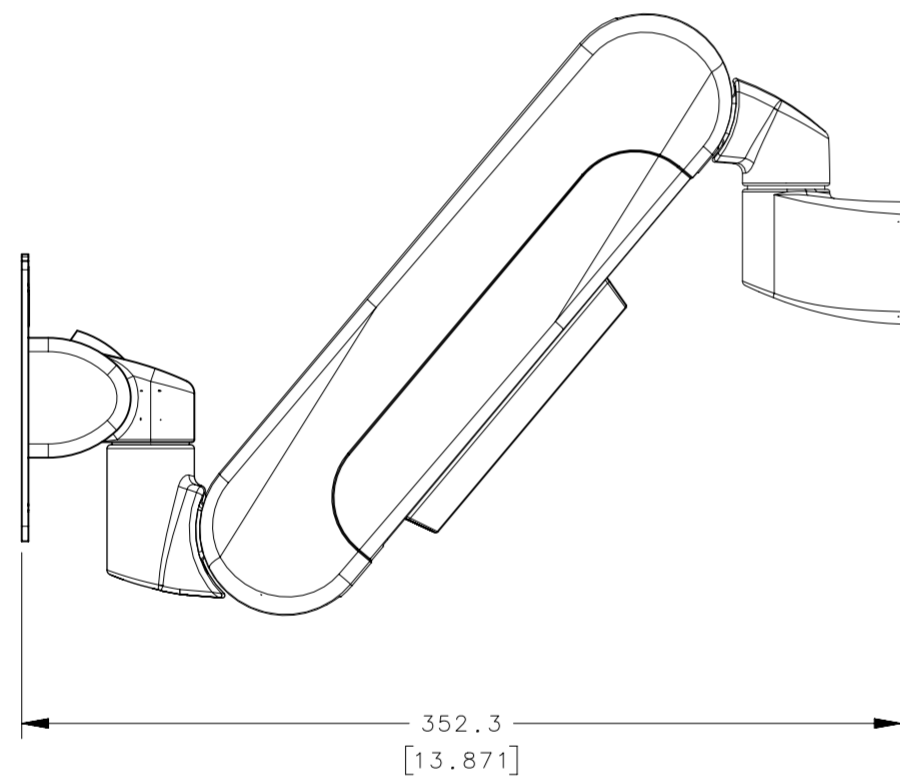

SECTION B-B

**WARNING:**  
TO REDUCE THE RISK OF INJURY MOVE ARM INTO HIGHEST POSITION BEFORE REMOVING DEVICE ATTACHED TO ARM. ARM TO REMAIN IN HIGHEST POSITION UNTIL DEVICE IS FULLY MOUNTED INTO THE ARM.

THIRD ANGLE PROJECTION			
MILLIMETERS [IN]			
TOLERANCES UNLESS OTHERWISE NOTED		DESCRIPTION	
ALL DIMENSIONS WITHOUT TOLERANCES ARE FOR REFERENCE ONLY.		HINGE & CONTROLLED MOTION DEVICE (STANDARD LIFT ARM, WALL MOUNT)	
PROPRIETARY ITEM EXCEPT FOR USES EXPRESSLY GRANTED IN WRITING. INFORMATION DISCLOSED HEREON IS CONFIDENTIAL AND ALL RIGHTS, PATENT AND OTHERWISE, ARE RESERVED BY SOUTHCO, INC.		SIZE SYSTEM	DWG NO.
PER ASME Y14.5M-1994		A2 NX	J-AV-D32-30V101
DRAWN BY		DATE	SCALE SHEET
GEA		01FEB2015	1:1 2 OF 4

8

7

6

5

4

3

2

1

8

7

6

5

4

3

2

1

REVISION HISTORY			
REV	DATE	BY	DESCRIPTION
C	01MAY2020	GEA/DMS	PRN: P2019-3080

REFER TO TABLE ON SHEET 1  
FOR RECOMMENDED DISPLAY  
WEIGHT RANGE

DISPLAY (NOT SUPPLIED)

DISPLAY MOUNTING SCREWS  
(NOT SUPPLIED)

M5X0.8 SCREWS (NOT SUPPLIED)

NOTE: ARM MOUNTING SCREWS MUST  
HAVE 10mm MINIMUM THREAD  
ENGAGEMENT.

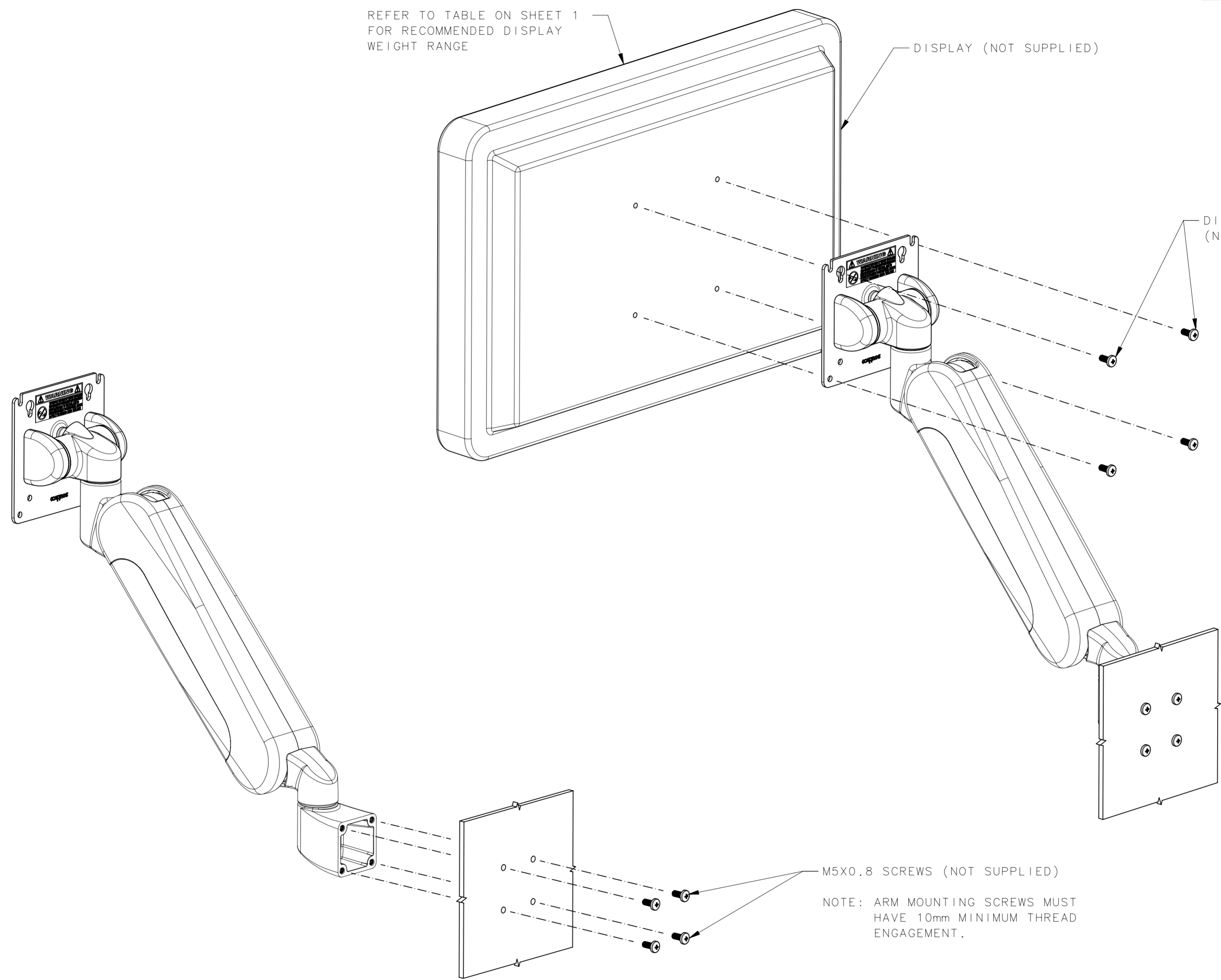

THIRD ANGLE PROJECTION				<b>southco</b> CONNECT · CREATE · INNOVATE	
MILLIMETERS [IN]					
SURFACE AREA	mm <sup>2</sup>	TOLERANCES UNLESS OTHERWISE NOTED		DESCRIPTION	
VOLUME	mm <sup>3</sup>	ALL DIMENSIONS WITHOUT TOLERANCES ARE FOR REFERENCE ONLY.		HINGE & CONTROLLED MOTION DEVICE (STANDARD LIFT ARM, WALL MOUNT)	
PROPRIETARY ITEM		SIZE	SYSTEM	DWG NO.	
EXCEPT FOR USES EXPRESSLY GRANTED IN WRITING, INFORMATION DISCLOSED HEREON IS CONFIDENTIAL AND ALL RIGHTS, PATENT AND OTHERWISE, ARE RESERVED BY SOUTHCO, INC.		A2	NX	J-AV-D32-30V101	
PER ASME Y14.5M-1994		DRAWN BY	DATE	SCALE	SHEET
		GEA	01FEB2015	1:1	3 OF 4

8

7

6

5

4

3

2

1

8

7

6

5

4

3

2

1

REVISION HISTORY			
REV	DATE	BY	DESCRIPTION
C	01MAY2020	GEA/DMS	PRN: P2019-3080

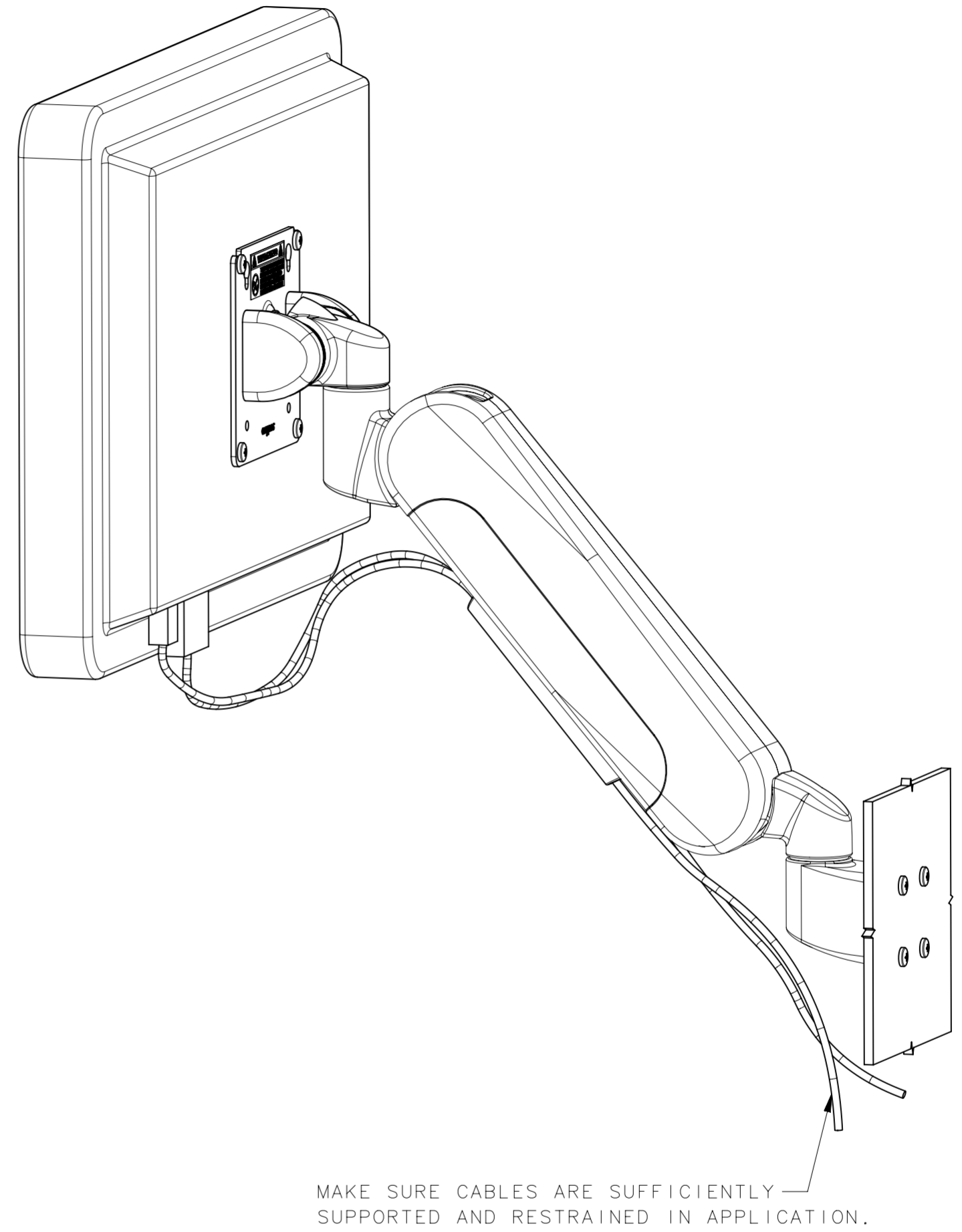
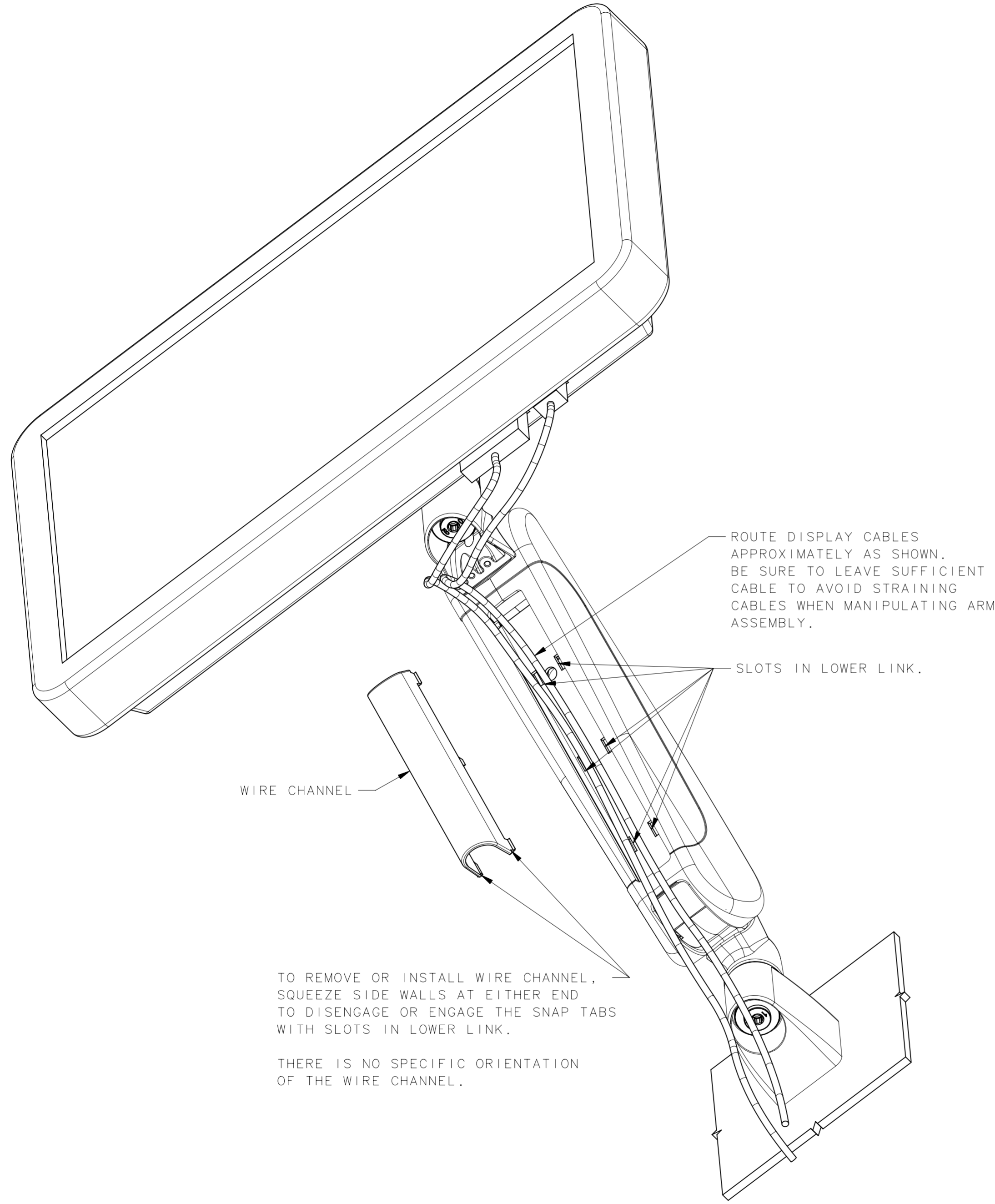

THIRD ANGLE PROJECTION				<b>southco</b> CONNECT · CREATE · INNOVATE	
MILLIMETERS [IN]					
SURFACE AREA		TOLERANCES UNLESS OTHERWISE NOTED		DESCRIPTION	
VOLUME		ALL DIMENSIONS WITHOUT TOLERANCES ARE FOR REFERENCE ONLY.		HINGE & CONTROLLED MOTION DEVICE (STANDARD LIFT ARM, WALL MOUNT)	
PROPRIETARY ITEM		PER ASME Y14.5M-1994		SIZE SYSTEM	
EXCEPT FOR USES EXPRESSLY GRANTED IN WRITING, INFORMATION DISCLOSED HEREON IS CONFIDENTIAL AND ALL RIGHTS, PATENT AND OTHERWISE, ARE RESERVED BY SOUTHCO, INC.		DRAWN BY		DWG NO.	
		GEA		J-AV-D32-30V101	
		DATE		SCALE	
		01FEB2015		1:1	
		SHEET		4 OF 4	

8

7

6

5

4

3

2

1