

REVISION HISTORY			
REV	DATE	BY	DESCRIPTION
F	18AUG2016	RNG/YGC	PRN: P2016-1911

2X 8-32 UNC-2B X .38 DEEP.
 Ø .196 MOUNTING HOLES IN PANEL.

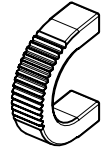

SCALE 1:2

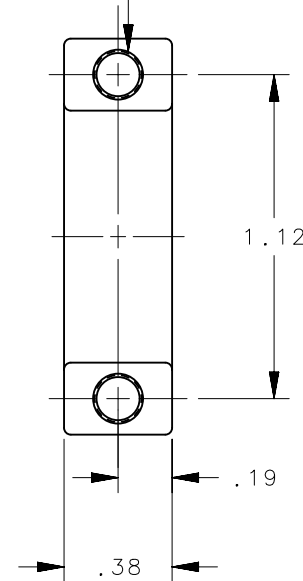
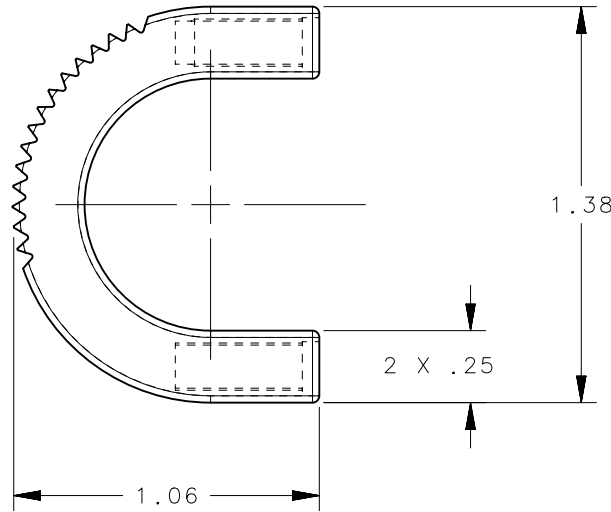

B4-10-103-11	PULL	6063 ALUMINUM	CLEAR ANODIZED
B4-10-103-12	PULL	6063 ALUMINUM	BLACK POWDER COATED
B4-10-103-13	PULL	6063 ALUMINUM	NATURAL
B4-10-103-15	PULL	6063 ALUMINUM	BLACK ANODIZE
B4-10-103-75	PULL	6063 ALUMINUM	SILVER POWDER COATED
PART NUMBER	TYPE OF COMPONENT	MATERIAL	FINISH

NOTES:

- COSMETIC SPECIFICATION:
 ALL SURFACES UNLESS OTHERWISE NOTED ARE TO CONFORM TO A CLASS "B" DESIGNATION AS DESCRIBED IN SOUTHCO COSMETIC SPECIFICATION:
 S-121-03 FOR POWDER COATING
 S-121-06 FOR ANODIZED FINISH
- RoHS COMPLIANT.

THIRD ANGLE PROJECTION		 CONNECT • CREATE • INNOVATE	
INCHES [MM]			
TOLERANCES UNLESS OTHERWISE NOTED		DESCRIPTION SOUTHCO NO. B4 PULL, 100 SERIES	
ALL DIMENSIONS WITHOUT TOLERANCES ARE FOR REFERENCE ONLY.		SIZE A	SYSTEM NX
PER ASME Y14.5M-1994		DWG NO. J-B4-10-103	
EXCEPT FOR USES EXPRESSLY GRANTED IN WRITING, INFORMATION DISCLOSED HEREON IS CONFIDENTIAL AND ALL RIGHTS, PATENT AND OTHERWISE, ARE RESERVED BY SOUTHCO, INC.		DRAWN BY VBS	DATE 13APR1984
		SCALE 1:1	SHEET 1 OF 1