

REVISION HISTORY			
REV	DATE	BY	DESCRIPTION
C	25OCT2018	CSN/SKB	PRN: P2018-2697

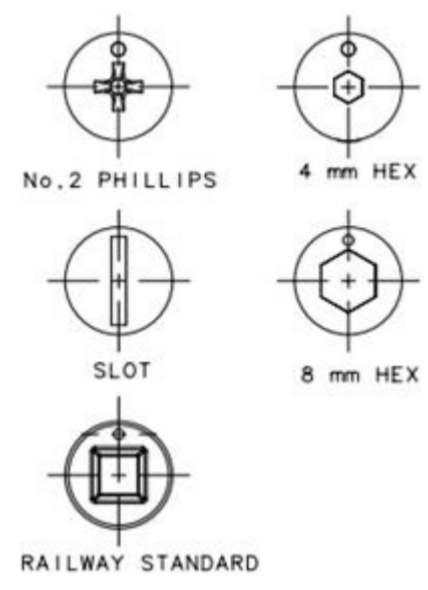
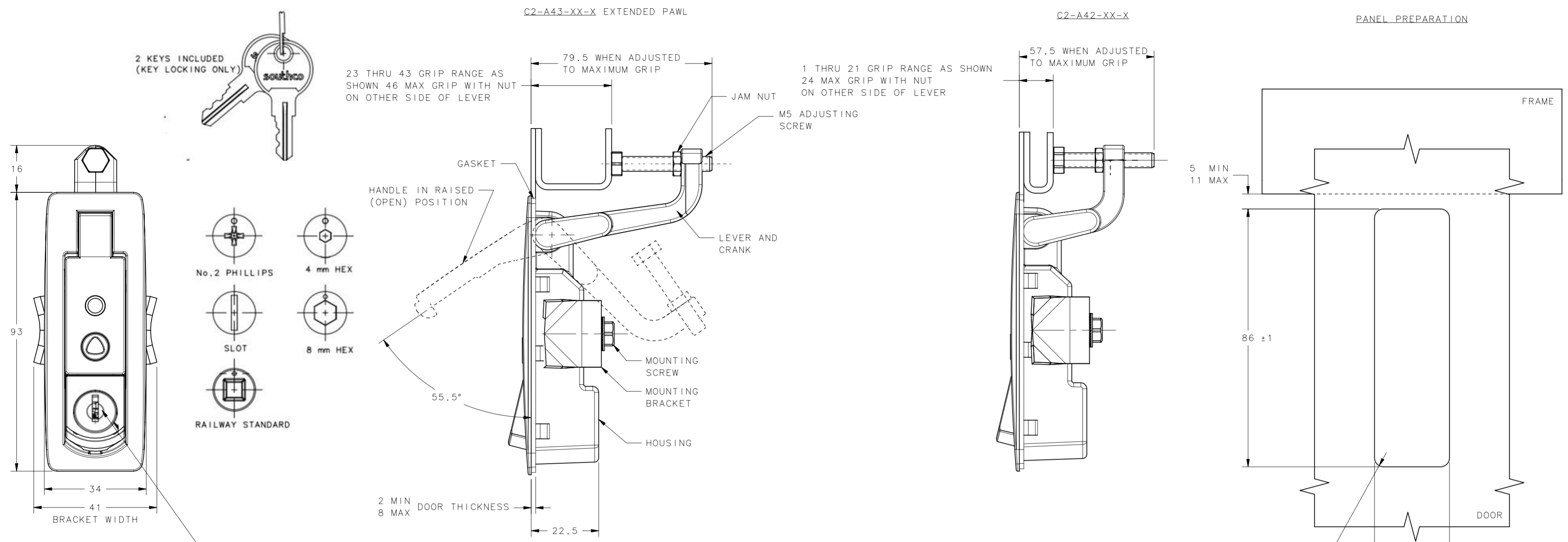

TRIGGER WITH KEY LOCKING OR TOOL ACCESS LOCK PLUG OR NON LOCKING

- LOCK STYLE**
- 1 NON- LOCKING RAISED TRIGGER
 - 2 KEY LOCKING RAISED TRIGGER
 - 3 FLUSH TRIGGER NON-LOCKING
 - 4 4(.16) HEX RECESS RAISED TRIGGER
 - 10 NO. 2 PHILLIPS RAISED TRIGGER
 - 13 LOCKING WITHOUT LOCK CORE
 - 14 RAILWAY STANDARD
 - 15 8 (.32) HEX RECESS RAISED TRIGGER
 - 16 SLOT HEAD

C2-A4G-LF-P

- FINISH**
- 1 TEXTURED CHROME.
 - 5 BLACK POWDER COAT.
- PACKAGING OPTION**
- 3 LATCHES ARE SOLD LAYER PACKED. OMIT FOR INDIVIDUALLY PACKAGED LATCHES.
- GRIP RANGE**
- 2 1 - 24mm
 - 3 23 - 46mm

- NOTES:**
- A. MATERIAL AND FINISH**
- HOUSING, HANDLE AND TRIGGER: DIE CAST ZINC BLACK POWDERCOAT
 - LEVER AND CRANK: DIE CAST ZINC, ZINC PLATE.
 - ADJUSTING SCREW, MOUNTING BRACKET, MOUNTING SCREW AND JAM NUT: STEEL, ZINC PLATE
 - GASKET: NEOPRENE, NATURAL
 - O-RING: RUBBER, NATURAL
 - TORSION SPRING: STAINLESS STEEL, NATURAL
 - U-SPRING: STAINLESS STEEL, PASSIVATED.
 - INDICATOR HOUSING AND CAM: DIECAST ZINC
 - INDICATOR SLIDE: PLASTIC
- B. LATCH INSTALLATION:**
- PLACE GASKET UNDER LIP OF HOUSING AND PLACE LATCH INTO PANEL PREP
 - INSERT MOUNTING SCREW INTO MOUNTING BRACKET AND SCREW INTO HOUSING. MOUNTING SCREW IS M5 THREAD. USE LONGER SCREWS (NOT SUPPLIED) FOR THICKER DOORS. MAXIMUM MOUNTING BOLT TORQUE 3.5Nm (30lbf.in)
 - ADJUST ADJUSTING SCREW TO REQUIRED GRIP AND TIGHTEN JAM NUT. MAXIMUM JAM NUT TORQUE 4Nm (35.4 lbf.in)
- C. LOCK PLUG INSTALLATION:**
- POSITION LOCK PLUG AND ORIENT RETAINING WAFER (LAST WAFER LOCATED AT THE BOTTOM OF LOCK) AT THE 9 O'CLOCK POSITION AND INSERT INTO THE TRIGGER.
 - BE SURE THE LOCK PLUG IS FULLY SEATED AGAINST THE TRIGGER.
- D. OPERATION**
- WHEN LATCH IS CLOSED, TRI-LOBE KEY (CAN BE ORDERED SEPARATELY, C2-26-301-05)MAY BE USED TO SET INDICATION TO GREEN.
 - WHEN LATCH IS OPENED INDICATION WITH CHANGE FROM GREEN TO RED.
 - INDICATION WILL REMAIN RED DURING OPEN AND CLOSE CYCLES UNTIL LATCH IS CLOSED AND INDICATION IS RESET TO GREEN WITH TRI-LOBE KEY.

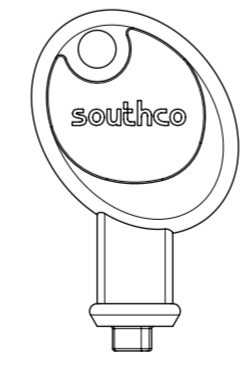

C2-26-301-05
RESET KEY FOR ACCESS INDICATOR
ORDERED SEPARATELY

TRIGGER OPTION	ASSEMBLY PART NUMBER			
	BLACK POWDER COAT		TEXTURED CHROME	
	GRIP 1 -24	GRIP 23 -46	GRIP 1 -24	GRIP 23 -46
NON LOCKING RAISED	C2-A42-15	C2-A43-15	C2-A42-11	C2-A43-11
NON LOCKING FLUSH	C2-A42-35	C2-A43-35	C2-A42-31	C2-A43-31
RAILWAY STANDARD	C2-A42-145	C2-A43-145	C2-A42-141	C2-A43-141
KEY LOCKING	C2-A42-25	C2-A43-25	C2-A42-21	C2-A43-21
4mm HEX	C2-A42-45	C2-A43-45	C2-A42-41	C2-A43-41
8mm HEX	C2-A42-155	C2-A43-155	C2-A42-151	C2-A43-151
SLOT HEAD	C2-A42-165	C2-A43-165	C2-A42-161	C2-A43-161
No. 2 PHILLIPS	C2-A42-105	C2-A43-105	C2-A42-101	C2-A43-101
WITHOUT LOCK PLUG	C2-A42-135	C2-A43-135	C2-A42-131	C2-A43-131

THIRD ANGLE PROJECTION

MILLIMETERS [IN]

TOLERANCES UNLESS OTHERWISE NOTED

ALL DIMENSIONS WITHOUT TOLERANCES ARE FOR REFERENCE ONLY.

PROPRIETARY ITEM EXCEPT FOR USES EXPRESSLY GRANTED IN WRITING. INFORMATION DISCLOSED HEREON IS CONFIDENTIAL AND ALL RIGHTS, PATENT AND OTHERWISE, ARE RESERVED BY SOUTHCO, INC.

PER ASME Y14.5M-1994

DESCRIPTION: SEALED C2 LEVER LATCH ASSEMBLY WITH ACCESS INDICATOR

SIZE: A2, SYSTEM: NX, DWG NO.: J-C2-A43-15

DRAWN BY: CSN, DATE: 25SEP2018, SCALE: 1:1, SHEET: 1 OF 2

southco
CONNECT · CREATE · INNOVATE

REVISION HISTORY			
REV	DATE	BY	DESCRIPTION
C	25OCT2018	CNS/SKB	PRN: P2018-2697

LATCH CLOSED
INDICATOR : RED

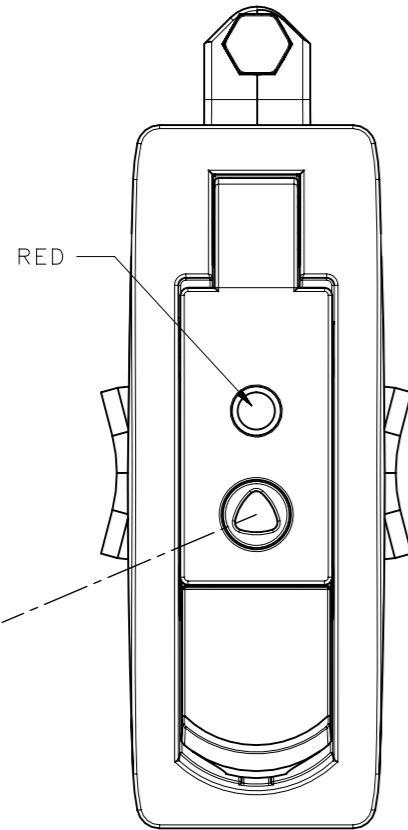

LATCH CLOSED
INDICATOR : RED

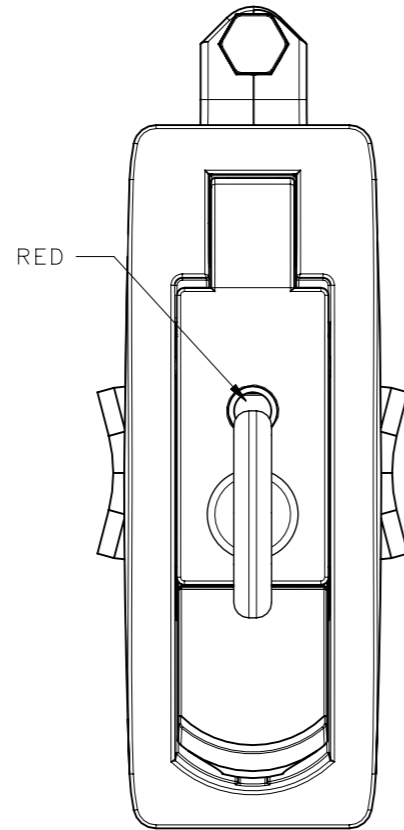

INSERT KEY C2-26-301-05
(SOLD SEPARATELY)

LATCH CLOSED
INDICATOR : RED/GREEN

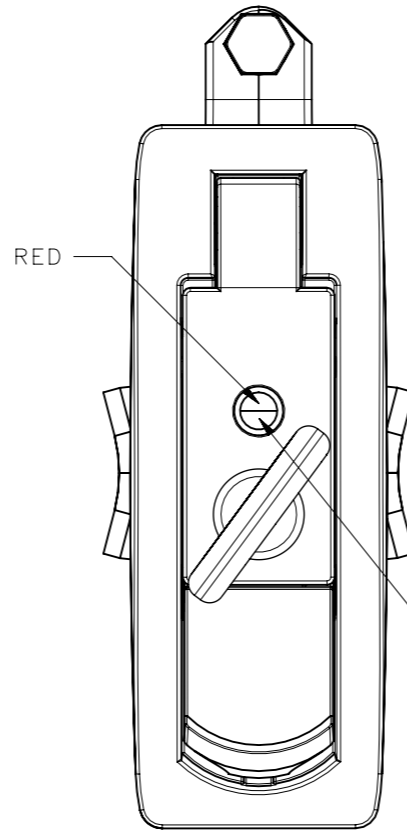

ROTATE KEY CLOCKWISE

LATCH CLOSED
INDICATOR : GREEN

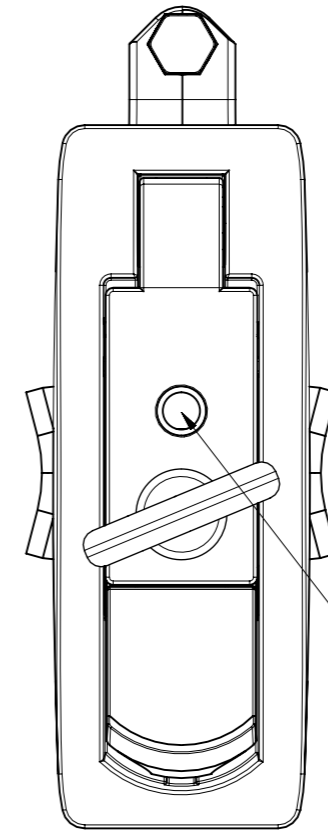

CONTINUE ROTATING KEY
CLOCKWISE UNTILL "CLICK"

LATCH CLOSED
INDICATOR : GREEN

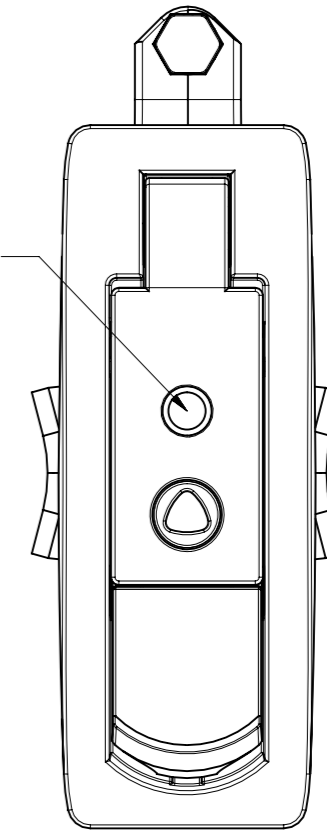

RELEASE KEY
INDICATOR STAYS GREEN

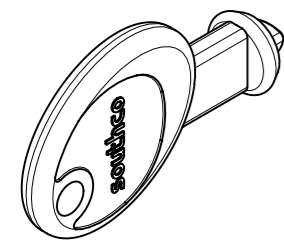

NOTES

1. SET THE INDICATOR TO GREEN, WHILE THE LATCH IS IN THE CLOSED POSITION.
2. INDICATOR WILL REMAIN GREEN UNTIL THE LATCH IS OPENED.
3. INDICATOR WILL REMAIN RED UNTIL RESET WITH SETTING KEY.
4. INDICATOR SETTING KEY, PART NUMBER C2-26-301-05, CAN BE PURCHASED SEPERATELY

THIRD ANGLE PROJECTION			southco [®] CONNECT • CREATE • INNOVATE	
TOLERANCES UNLESS OTHERWISE NOTED		DESCRIPTION SEALED C2 LEVER LATCH ASSEMBLY WITH ACCESS INDICATOR		
ALL DIMENSIONS WITHOUT TOLERANCES ARE FOR REFERENCE ONLY.		SIZE A3	SYSTEM NX	DWG NO. J-C2-A43-15
PER ASME Y14.5M-1994		DRAWN BY CSN	DATE 25SEP2018	SCALE 1:1
<small>PROPRIETARY ITEM EXCEPT FOR USES EXPRESSLY GRANTED IN WRITING, INFORMATION DISCLOSED HEREON IS CONFIDENTIAL AND ALL RIGHTS, PATENT AND OTHERWISE, ARE RESERVED BY SOUTHCO, INC.</small>		SHEET 2 OF 2		