



SOUTHCO SOFT-LATCH™
FLEXIBLE COVER DRAW LATCH

DATE	DRAWN	CHKD	SCALE	DRAWING NUMBER
10-24-89	JCG		1:1	J-C7-11

REV.	DATE	BY-CHKD	REVISIONS	ITEM	COMPONENT	PART NO.	MATERIAL	FINISH
A	7/27/90	JAD	PRN:C7-11	ASSEMBLY		C7-11		
B	12-19-90	RHB	PRN C7-14		LATCH SUB-ASSL'Y		SEE NOTE 1.	SEE NOTE 1.
C	12 JAN. 93	KPL	PRN:S-1-03		KEEPER		TYPE 304 STAINLESS STEEL	PASSIVATED
D	08MAY95	MDM	PRN:C7-27					
E	08DEC95	AJH	PRN: C7-34					

NOTES:

- LATCH SUB-ASSEMBLY CONSISTS OF:
LATCH BODY - THERMOPLASTIC ELASTOMER, BLACK
LEVER AND BUSHINGS - GLASS REINFORCED NYLON, BLACK
BRACKET - 304 SERIES STAINLESS STEEL, PASSIVATED
PINS - 300 SERIES STAINLESS STEEL, PASSIVATED
RIVET - 430 STAINLESS STEEL, PASSIVATED
- MOUNT USING 4 mm OR 5/32 DIA. RIVETS OR
No. 8 OR M4 SIZE HARDWARE.
- LATCH APPLIES APPROX. 16 lb STEADY STATE
CLAMP LOAD AT ROOM TEMPERATURE.

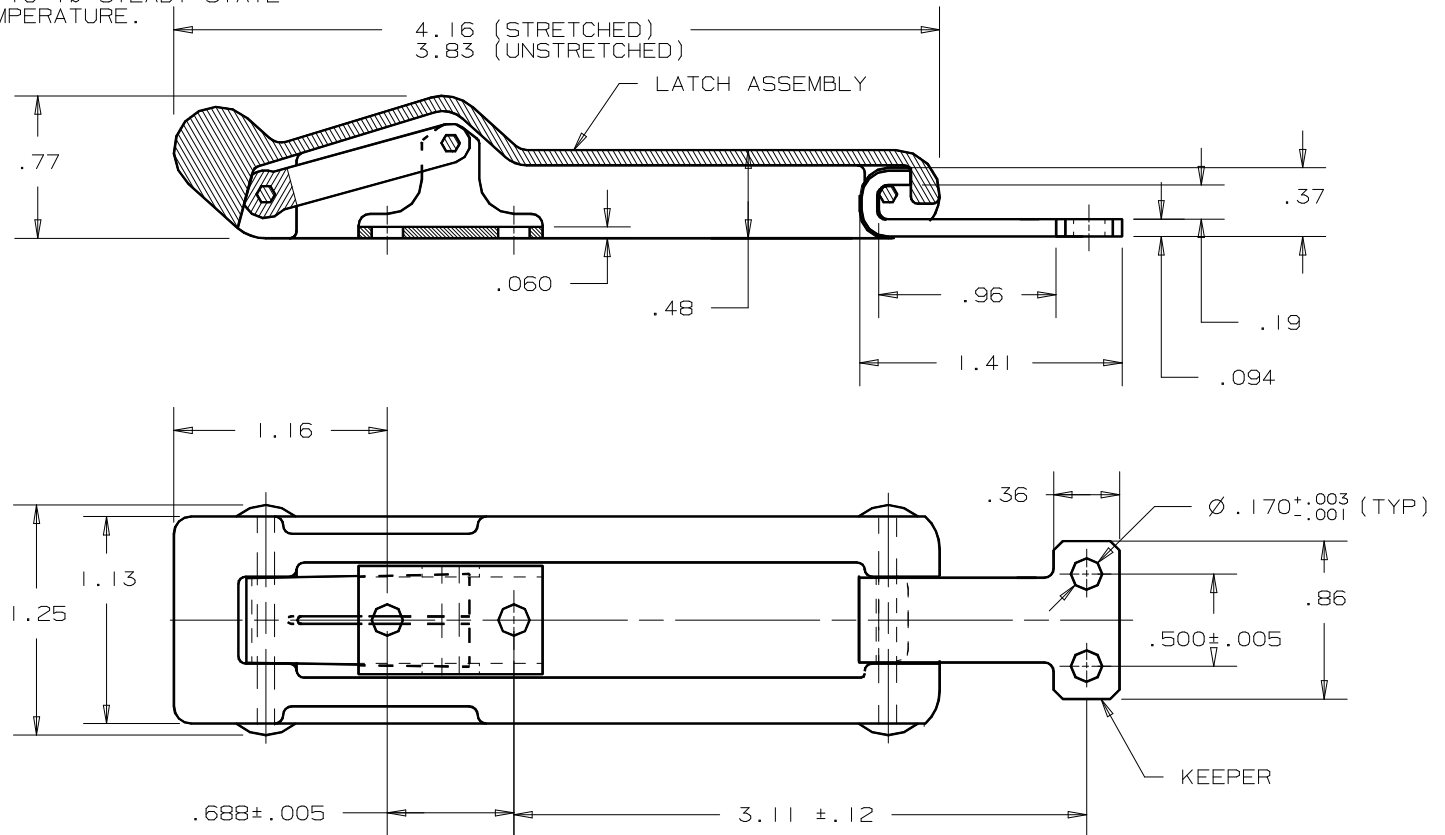

MOUNTING DIMENSIONS

FORMAT A 3/88

PROPRIETARY ITEM - EXCEPT FOR USES EXPRESSLY GRANTED IN WRITING
INFORMATION DISCLOSED HEREON IS CONFIDENTIAL AND ALL RIGHTS PATENT
AND OTHERWISE ARE RESERVED BY SOUTHCO, INC.

PATENTED

ALL DIMENSIONS WITHOUT TOLERANCES
ARE FOR REFERENCE ONLY

DRAWING NUMBER

J-C7-11