

OPEN/SHIPPING POSITION

(SEE NOTE B)

Ø5.4
(SEE NOTE A)

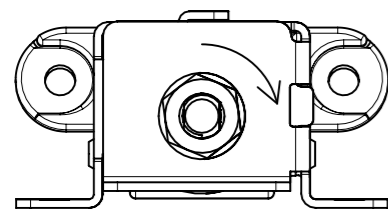
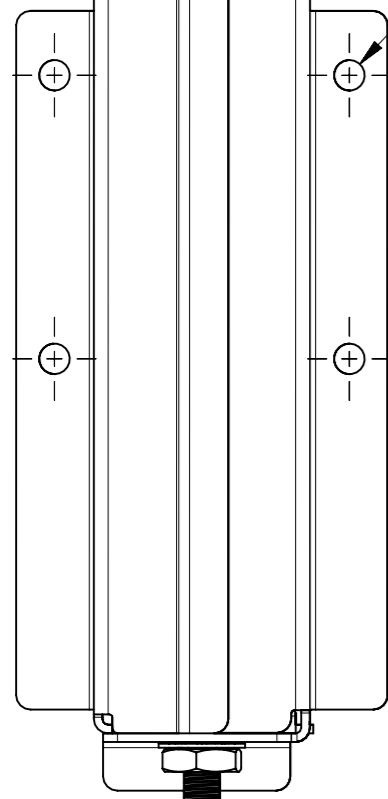
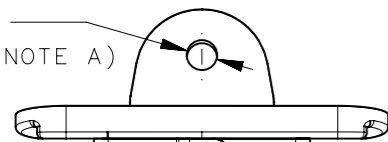

MAXIMUM OPEN ANGLE OF HINGE

80°

UPWARD

DOWNWARD

12.7

(SEE NOTE A)

DIRECTION TO INCREASE SPRING PRELOAD

(SEE NOTE C)

ADJUSTMENT NUT AND LOCKWASHER

"D"

LID WEIGHT

CA-50 Hinge Model Selection Guide

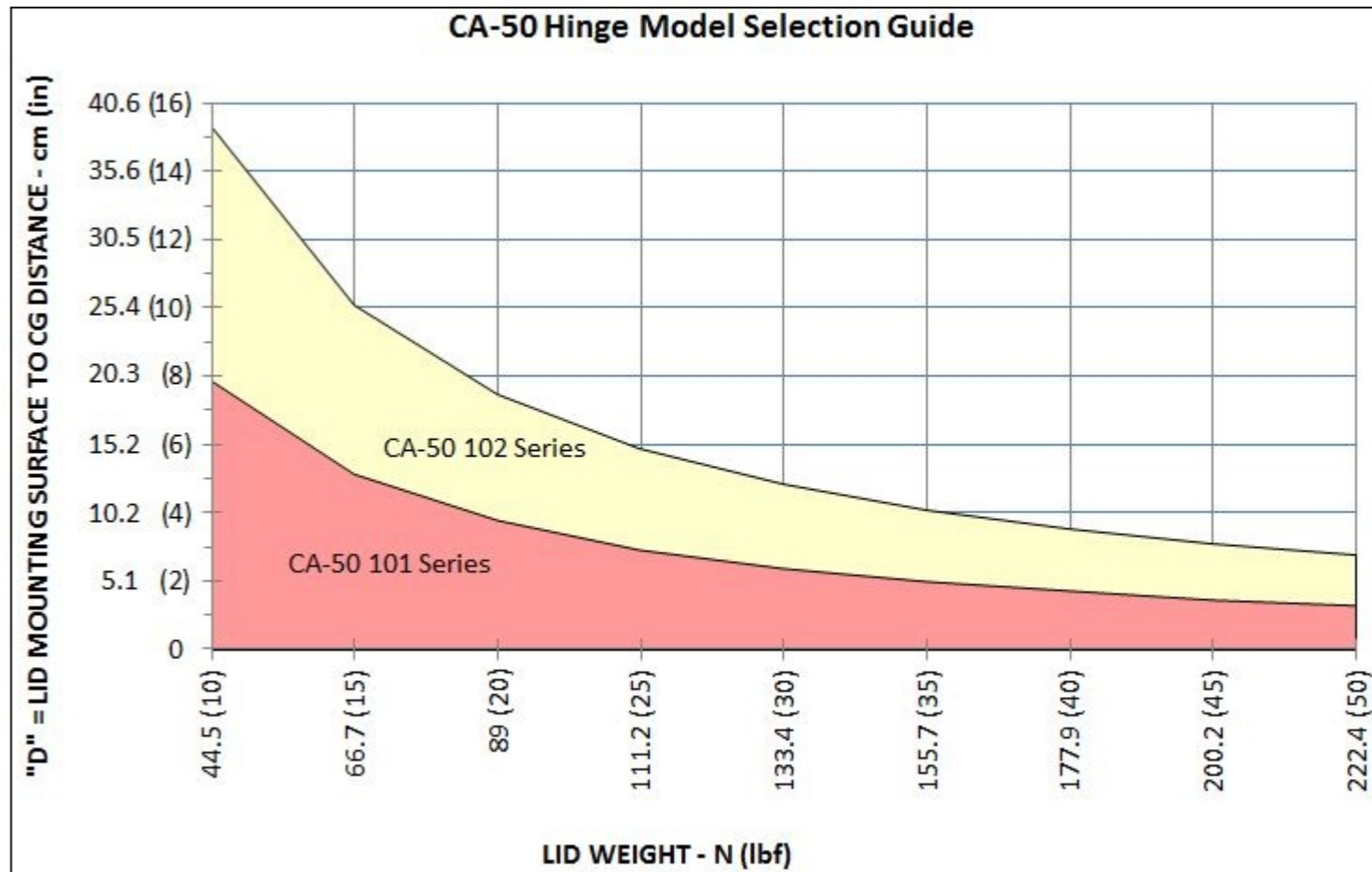

REVISION HISTORY			
REV	DATE	BY	DESCRIPTION
E	31MAR2017	CMS/LCR	PRN: P2017-0755

NOTES:

FOR SAFE INSTALLATION AND REMOVAL OF HINGE, HINGE MUST BE IN THE OPEN/SHIPPING POSITION SHOWN ABOVE LEFT.

- A. DESIGNED TO ACCEPT M5 OR No. 10 SCREWS OR EQUIVALENT.(7 LOCATIONS)
- B. HINGE IS SHIPPED IN THE POSITION SHOWN ABOVE LEFT. THE POSITION OF THE NUT IS SET AT THE MINIMUM PRE-LOAD OF THE SPRING(S) AND THE CAST HOUSING IS AT AN 80° ANGLE TO THE STAMPED HOUSINGS.
- C. SPRING PRE-LOAD ADJUSTMENT (IF NECESSARY):
ONCE HINGE IS INSTALLED, CLOSE LID. TO INCREASE THE SPRING PRE-LOAD, TURN THE ADJUSTMENT NUT CLOCKWISE UNTIL LID CAN STAY OPEN THROUGHOUT RANGE OF MOTION AND CAN STILL CLOSE. TO DECREASE THE PRE-LOAD, TURN THE NUT COUNTER-CLOCKWISE.
- D. THE HINGE HAS A CYCLE LIFE OF 40,000 CYCLES WHEN USED IN THE ORIENTATION SHOWN IN AMBIENT TEMPERATURES AND NOT EXCEEDING THE WEIGHT VS CG CHART ABOVE.
- E. HINGE IS RECOMMENDED FOR INDOOR USE ONLY.
- F. HINGE INTENDED FOR USE IN THE ORIENTATION SHOWN ABOVE WHERE THE CLOSED POSITION 0° IS HORIZONTAL AND THE OPEN POSITION IS 80° MAXIMUM FROM HORIZONTAL.

*SOUTHCO PERFORMANCE AND APPLICATION GUIDELINES ARE SUPPLIED AS GENERAL GUIDES ONLY, AS CONDITIONS VARY WITH EACH APPLICATION AND INSTALLATION METHOD. REPRESENTED CYCLE PERFORMANCE IS NOT A GUARANTEE OF RELIABILITY UNDER ACTUAL USAGE CONDITIONS IN END USER PRODUCT APPLICATIONS. USERS MUST TEST POTENTIAL PRODUCT SOLUTIONS UNDER ACTUAL APPLICATION CONDITIONS AND ENVIRONMENT TO DETERMINE SUITABILITY OF THE PRODUCT FOR THE PURPOSE AND FUNCTION INTENDED BY THE USER AND TO ASSURE DESIRED PERFORMANCE.

PART NUMBER	MAXIMUM LID MOMENT PER HINGE N-m(lbf-in)	DOWNWARD FRICTION TORQUE N*m (lbf*in)	UPWARD FRICTION TORQUE N*m (lbf*in)
CA-50-101-50	9.4(83)	3.6(32)	2.8(25)
CA-50-102-50	17.7(157)	3.6(32)	2.8(25)

THIRD ANGLE PROJECTION

MILLIMETERS [IN]

TOLERANCES UNLESS OTHERWISE NOTED

ALL DIMENSIONS WITHOUT TOLERANCES ARE FOR REFERENCE ONLY.

PER ASME Y14.5M-1994

PROPRIETARY ITEM
EXCEPT FOR USES EXPRESSLY GRANTED IN WRITING, INFORMATION DISCLOSED HEREON IS CONFIDENTIAL AND ALL RIGHTS, PATENT AND OTHERWISE, ARE RESERVED BY SOUTHCO, INC.

southco[®]
CONNECT • CREATE • INNOVATE

DESCRIPTION
COUNTERBALANCE HINGE

SIZE: A3 SYSTEM: NX DWG NO.: J-CA-50-100

DRAWN BY: LCR DATE: 15JAN2013 SCALE: 0.75:1 SHEET: 1 OF 2

NOTE:
 VIEWS BELOW SHOW THE HINGE IN THE "CLOSED" POSITION FOR REFERENCE. THE HINGE WILL NOT BE IN THIS STATE UNTIL INSTALLED IN THE FINAL APPLICATION. THE SPRING FORCES WILL NATURALLY KEEP THE UNINSTALLED HINGE IN THE "OPEN/SHIPPING" POSITION.

REVISION HISTORY			
REV	DATE	BY	DESCRIPTION
E	31MAR2017	CMS/LCR	PRN: P2017-0755

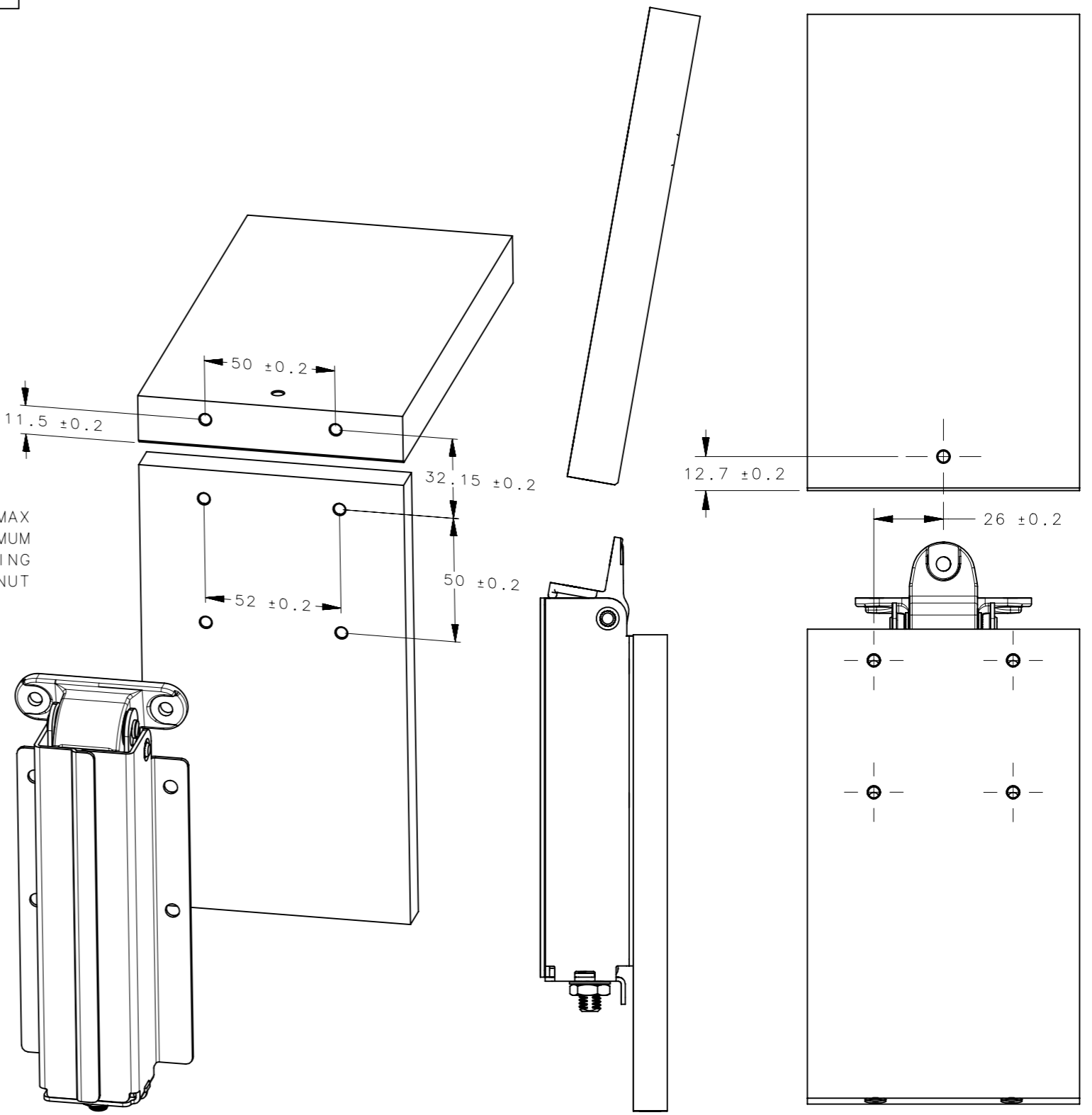
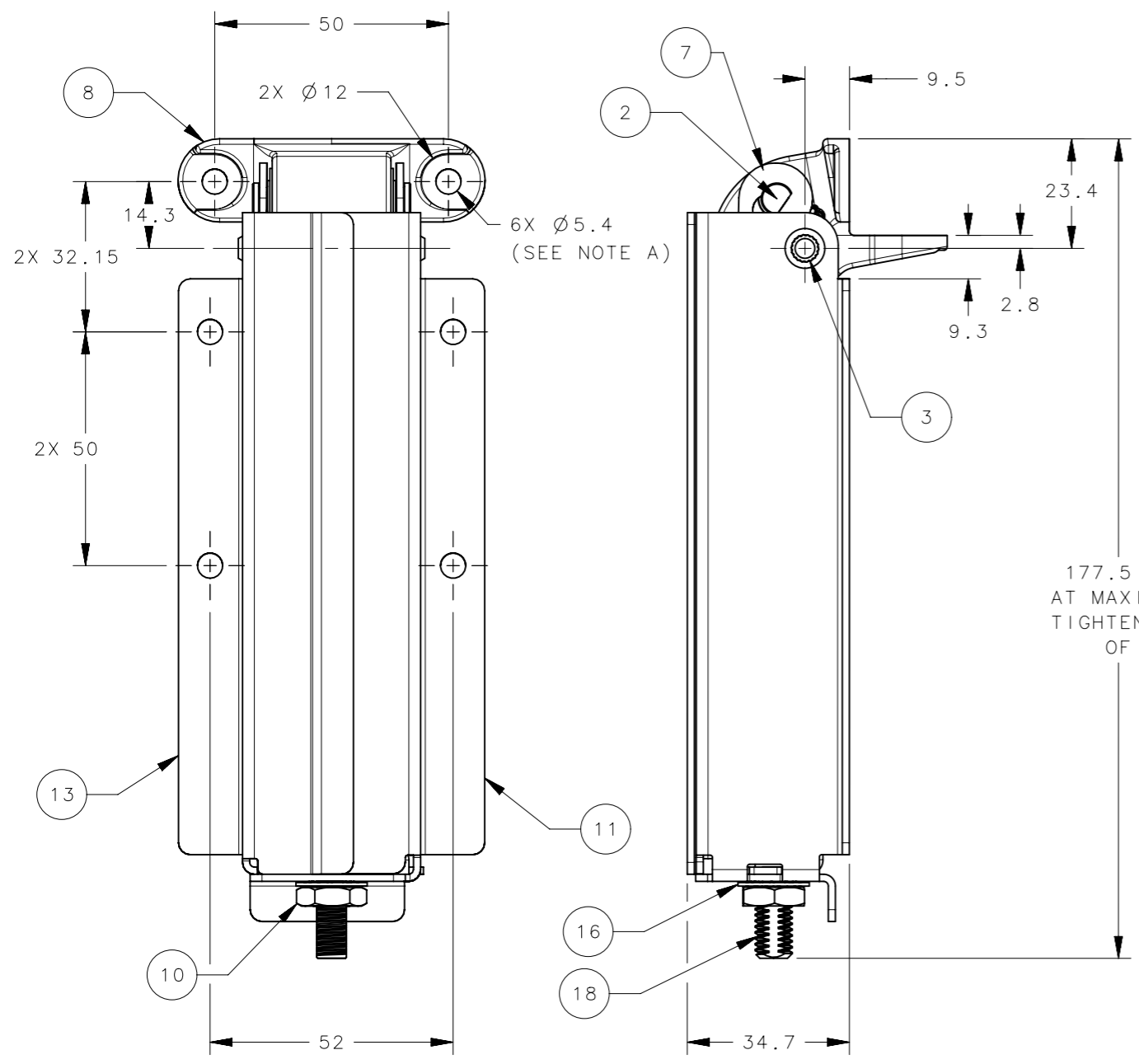

19	1	SPRING, INNER	STEEL	ZINC PLATING	ONLY IN CA-50-102-50
18	1	SHAFT	STEEL	ZINC PLATING	
17	1	SPRING	STEEL	BLACK POWDER COATING	INTERNAL COMPONENT
16	1	WASHER	SPRING STEEL	ZINC PLATING	
15	1	CLIP	STEEL	BLACK POLYMER COATING	INTERNAL COMPONENT
14	1	BUSHING	NYLON	NATURAL	INTERNAL COMPONENT
13	1	HOUSING	STEEL	BLACK POWDER COATING	
12	1	BUSHING	PLASTIC	NATURAL	INTERNAL COMPONENT
11	1	HOUSING	STEEL	BLACK POWDER COATING	
10	1	ADJUSTMENT NUT	STEEL	ZINC PLATING	
9	2	CAP	STEEL	BLACK POWDER COATING	INTERNAL COMPONENT
8	1	HOUSING	ALUMINUM	BLACK POWDER COATING	
7	1	GUIDE	STEEL	BLACK POWDER COATING	
6	2	BUSHING	PLASTIC	GRAY	INTERNAL COMPONENT
5	1	PIN	STEEL	OILED	INTERNAL COMPONENT
4	16	TORQUE ELEMENT	STEEL	POLISHED	INTERNAL COMPONENT
3	1	SHAFT	STEEL	TUMBLER	
2	1	PIN	STEEL	ZINC PLATING	
1	2	BUSHING	BRASS	NATURAL	INTERNAL COMPONENT
NO.	QTY	TYPE OF COMPONENT	MATERIAL	FINISH	NOTES

THIRD ANGLE PROJECTION				 CONNECT • CREATE • INNOVATE		
TOLERANCES UNLESS OTHERWISE NOTED		DESCRIPTION				
ALL DIMENSIONS WITHOUT TOLERANCES ARE FOR REFERENCE ONLY.		COUNTERBALANCE HINGE				
PROPRIETARY ITEM	PER ASME Y14.5M-1994	SIZE A3	SYSTEM NX	DWG NO. J-CA-50-100		
EXCEPT FOR USES EXPRESSLY GRANTED IN WRITING, INFORMATION DISCLOSED HEREON IS CONFIDENTIAL AND ALL RIGHTS, PATENT AND OTHERWISE, ARE RESERVED BY SOUTHCO, INC.		DRAWN BY LCR	DATE 15JAN2013	SCALE 1:2	SHEET 2 OF 2	