

REVISION HISTORY			
REV	DATE	BY	DESCRIPTION
1	08MAY2023	GJL/DMS	PRN: P2023-0843

PART NUMBER : CM - 2 - [] 1 [] - 2 [] []

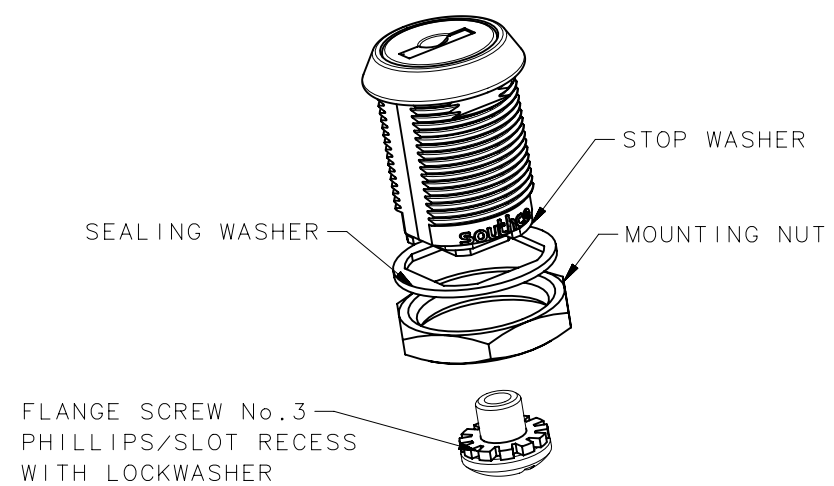

HOUSING LENGTHS:
1= .625
2= .875
6= 1.125
3= 1.375
4= 1.625
5= 1.875

CAM ROTATION ANGLE:
01= 12-3 O' CLOCK (CW)
09= 12-9 O' CLOCK (CCW)

KEY REMOVAL :
B- LOCKED/UNLOCKED
POSITION
L- LOCKED POSITION
ONLY

HOUSING FINISH:
B= BLACK POWDER COATED
C= CHROME PLATED

PLUG FINISH:
B- BLACK POWDER COAT (NO SHUTTER)
C- BRIGHT CHROME (NO SHUTTER)
M- MARKED SCALP, STAINLESS STEEL SCALP
PLUS STEEL, NICKEL PLATED SHUTTER
N- BRIGHT NICKEL (NO SHUTTER)
P- MARKED SCALP, BLACK POWDER COAT
R- MARKED SCALP, BRIGHT CHROME
S- STAINLESS STEEL SCALP PLUS
STEEL, NICKEL PLATED SHUTTER
T- STAINLESS STEEL SCALP
U- NO LOCK PLUG
(NOTE: STANDARD CODE MARKING IS IMPRINTED ON
KEY(S). LOCKS WITH "MARKED SCALP" HAVE
ADDITIONAL CODE MARKING ON THE SCALP.)

NOTES:
1. FOR INSTALLATION AND PANEL PREPERATION
SEE DRAWING J-CM-2-A..
2. SEE J-CM-C FOR CAM PART NUMBERS.

SUB-ASSEMBLY
PART No. CM-2-2B101-2SB SHOWN
(CAM ORDERED SEPARATELY)
SEE DWG J-CM-C FOR CAM PART NUMBERS

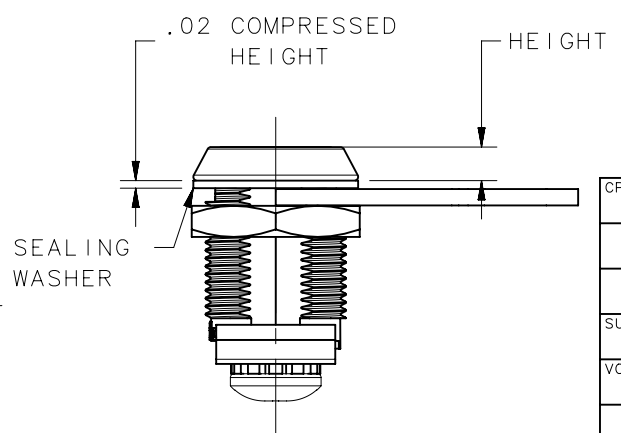
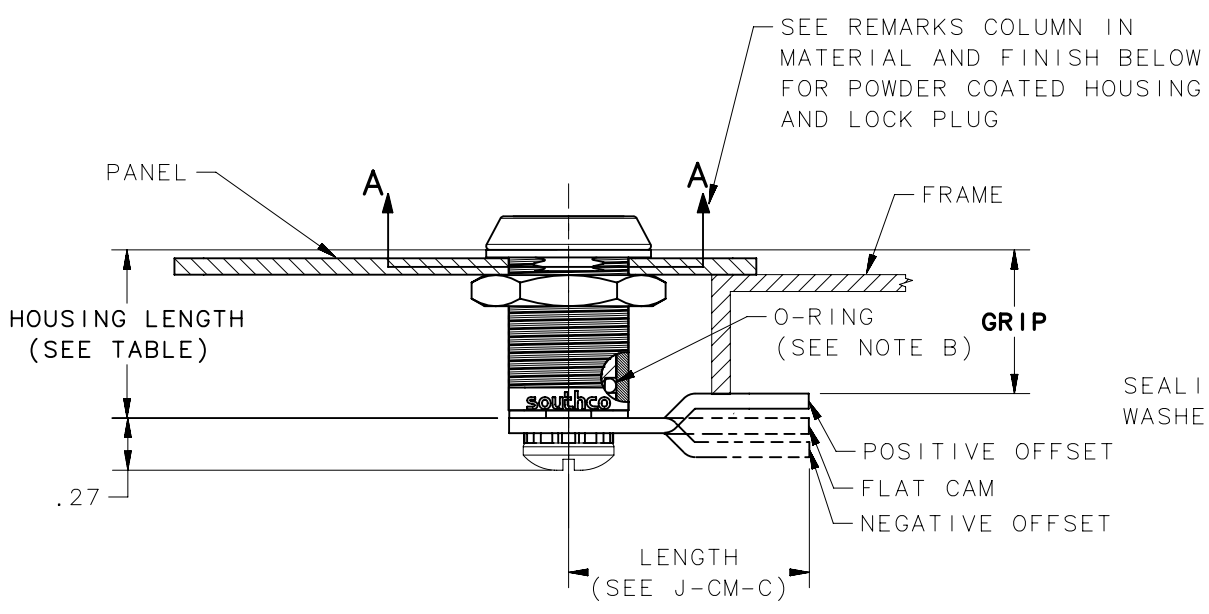
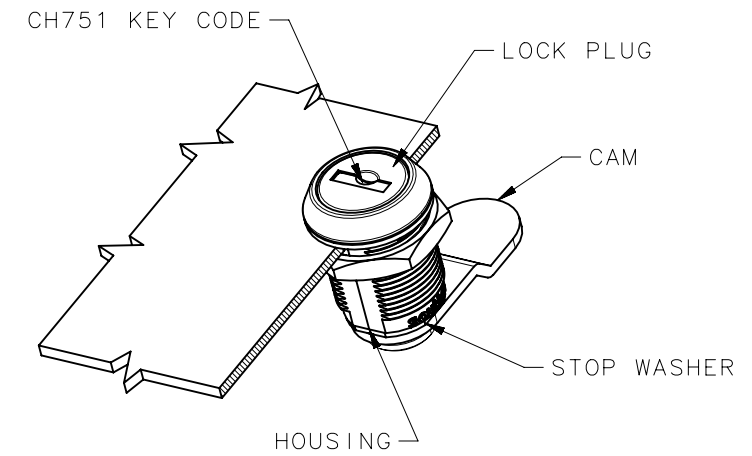
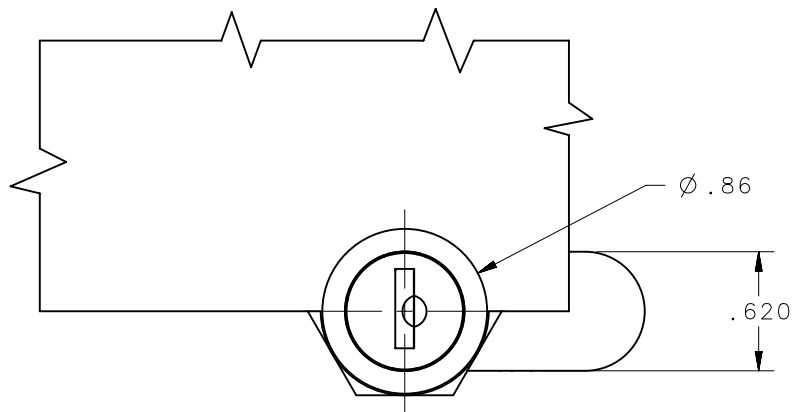
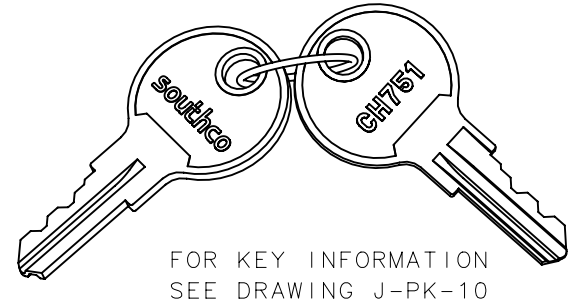

PART NUMBER CM-2-2B101-2SB SHOWN
ASSEMBLED WITH CAM P/N CM-C210
(CAM ORDERED SEPARATELY)

	HOUSING LENGTH	HEIGHT
1	.625	.25
2	.875	.18
6	1.125	.18
3	1.375	.18
4	1.625	.18
5	1.875	.18

CPB NUMBER	STANDARD	THIRD ANGLE PROJECTION			
SURFACE AREA		INCHES [MM]			
VOLUME		TOLERANCES UNLESS OTHERWISE NOTED	DESCRIPTION CAM LOCK, FLAT KEY STYLE, SEALED		
PROPRIETARY ITEM		ALL DIMENSIONS WITHOUT TOLERANCES ARE FOR REFERENCE ONLY.	SIZE B	SYSTEM NX	DWG NO. J-CM-2
PER ASME Y14.5M-1994			DRAWN BY DLH/BS	DATE 13APR2003	SCALE 1:1
EXCEPT FOR USES EXPRESSLY GRANTED IN WRITING, INFORMATION DISCLOSED HEREON IS CONFIDENTIAL AND ALL RIGHTS, PATENT AND OTHERWISE, ARE RESERVED BY SOUTHCO, INC.			SHEET 1 OF 2		

6

5

4

3

2

1

REVISION HISTORY

REV	DATE	BY	DESCRIPTION
1	08MAY2023	GJL/DMS	PRN:P2023-0843

CAM ROTATION DIRECTION

NOTE :

1. LOCK PLUG POSITION SHOWN IN UNLOCKED POSITION. SOLID LINE CAM DEPICTS UNLOCKED CAM POSITION. DOTTED LINE CAM DEPICTS LOCKED CAM POSITION. LOCK PLUG IN THE LOCKED POSITION IS NOT SHOWN.

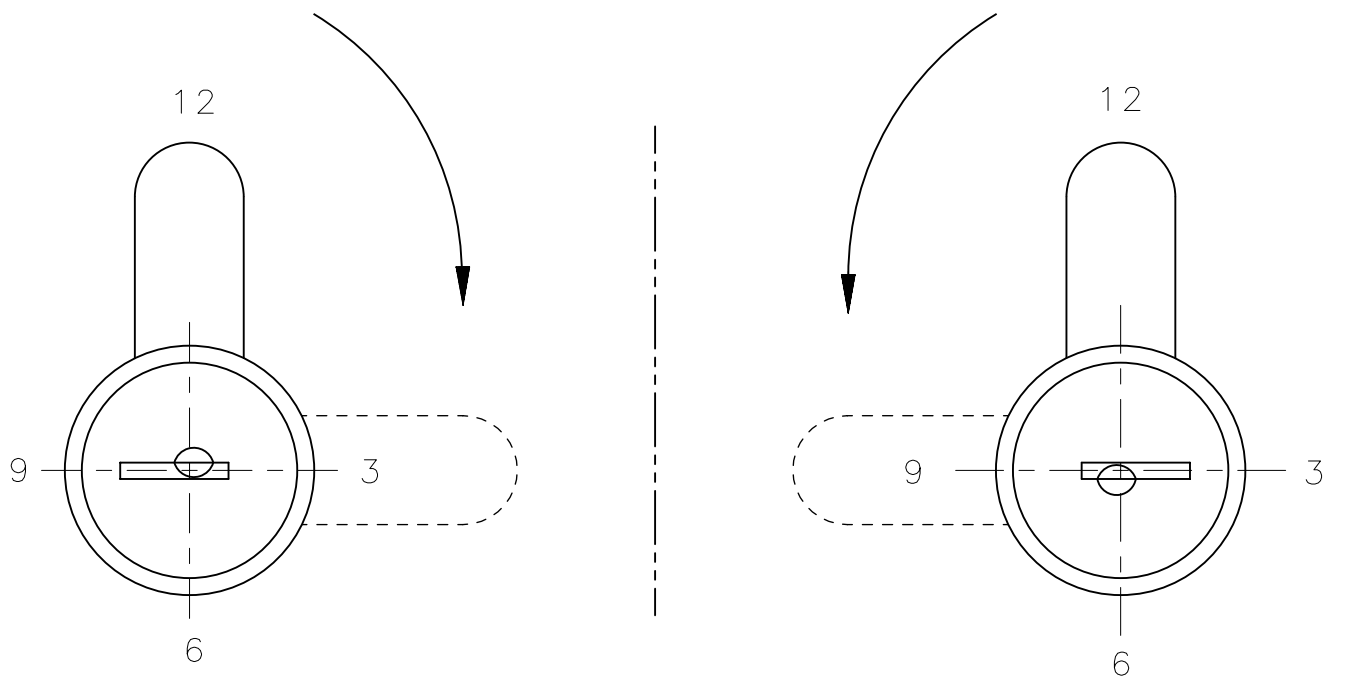

01 = 12-3 O'CLOCK (CW)

09 = 12-9 O'CLOCK (CCW)

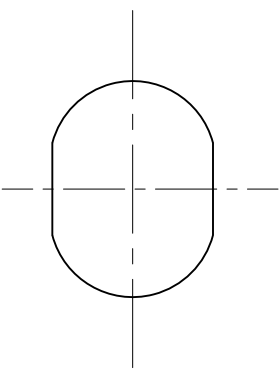

PANEL PREPERATION ORIENTATION

MATERIAL AND FINISH :

COMPONENT	MATERIAL DESCRIPTION	FINISH DESCRIPTION	REMARKS
LOCK PLUG BODY	DIE CAST ZINC	TRIVALENT CHROMATE CONV. COATED	
HOUSING	DIE CAST ZINC	CHROME PLATED	
		TRIVALENT CHROMATE CONV. COATED & POWDER COATED	HEAD IS POWDER COATED ABOVE SECTION B-B
CAM	STEEL	ZINC PLATE, BRIGHT CHROMATE CONV. COATING	
O-RING	NITRILE	BLACK	
SEALING WASHER	NATURAL RUBBER (80°)	BLACK	
STOP WASHER	STEEL	NICKEL PLATING PER BS3382 PART 3	
SCREW WITH LOCKWASHER	STEEL	ZINC PLATE, BRIGHT CHROMATE CONV. COATING	
MOUNTING NUT	DIE CAST ZINC	TRIVALENT CHROMATE CONV. COATING	
LOCK SCALP	STAINLESS STEEL	NATURAL	
SHUTTER	BRASS	NICKEL PLATE	
SHUTTER SPRING	STEEL ALLOY	HEAT TREAT	
WAFERS	BRASS	NATURAL	
WAFER SPRINGS	STAINLESS STEEL	NATURAL	

CPB NUMBER	STANDARD	THIRD ANGLE PROJECTION	 CONNECT · CREATE · INNOVATE			
		INCHES [MM]				
SURFACE AREA	TOLERANCES UNLESS OTHERWISE NOTED		DESCRIPTION CAM LOCK, FLAT KEY STYLE, SEALED			
VOLUME	ALL DIMENSIONS WITHOUT TOLERANCES ARE FOR REFERENCE ONLY.		SIZE B	SYSTEM NX	DWG NO. J-CM-2	
PROPRIETARY ITEM	PER ASME Y14.5M-1994		DRAWN BY DLH/BS	DATE 13APR2003	SCALE 1:1	SHEET 2 OF 2
<small>EXCEPT FOR USES EXPRESSLY GRANTED IN WRITING, INFORMATION DISCLOSED HEREON IS CONFIDENTIAL AND ALL RIGHTS, PATENT AND OTHERWISE, ARE RESERVED BY SOUTHCO, INC.</small>						

6

5

4

3

2

1