



PROPRIETARY ITEM - EXCEPT FOR USES EXPRESSLY GRANTED IN WRITING INFORMATION DISCLOSED HEREON IS CONFIDENTIAL AND ALL RIGHTS PATENT AND OTHERWISE ARE RESERVED BY SOUTHCO, INC.

CR STAINLESS STEEL COMPRESSION SWING HANDLE MULTI-POINT LATCHING SYSTEM

DATE: 21JUL2006
DRAWN: RDS
CHKD: NTS

DRAWING NUMBER: J-CR-19

REV	DATE	DRAWN/CHKD	DESCRIPTION	PART NUMBER
B	25FEB2014	CMS/JCK	PRN: P2014-0383	SEE TABLES
C	06MAY2014	CMS/BGL	PRN: P2014-0890	
D	07JAN2016	CMS/LT	PRN: P2016-0025	
E	22MAR2016	CMS/MGG	PRN: P2016-0641	
F	14FEB2017	CMS/MSR	PRN: P2017-0369	
G	13JUN2017	CMS/RO	PRN: P2017-1406	
H	12APR2019	CMS/DMS	PRN: P2019-0802	
I	03DEC2019	CMS/MGG	PRN: P2019-2929	

MILLIMETERS

ALL DIMENSIONS WITHOUT TOLERANCES ARE FOR REFERENCE ONLY.



THIRD ANGLE PROJECTION

A3 PAPER SIZE

SHEET 1 OF 4

FORMULAS FOR PRODUCT SELECTION:

USE MILLIMETERS FOR ALL CALCULATIONS.
IF HANDLE ACTUATOR SHAFT IS NOT CENTERED IN DOOR,
EACH ROD AND ROD END MUST BE CALCULATED INDIVIDUALLY.

ROD LENGTH = "L" (SEE SHEET 2) - 19.5 [ROUND DOWN TO WHOLE MILLIMETER]

ROD ENDS: SELECT THE ROD END WITH THE LEAST AMOUNT OF OFFSET IN WHICH THE DESIGNED ROD GRIP LENGTH IS WITHIN THE CALCULATED MAXIMUM AND MINIMUM GRIP LENGTH

NOMINAL ROD HEIGHT = OUTER DOOR PANEL THICKNESS + 48.3

ROD GRIP LENGTH (MAX) = NOMINAL ROD HEIGHT + ROD END OFFSET + (0.04366 X (ROD LENGTH + 5))

ROD GRIP LENGTH (MIN) = NOMINAL ROD HEIGHT + ROD END OFFSET - (0.04366 X (ROD LENGTH + 5))

NOTES:

- A. MATERIAL AND FINISH (RoHS COMPLIANT): SEE J-CR-19, SHEET 4
- B. FOR PANEL PREPARATION AND LATCH INSTALLATION INSTRUCTIONS REFER TO SHEETS 2, 3 & 4 OF THIS DRAWING

HANDLE ACTUATOR			
PART NUMBER	HOUSING STYLE	LOCK SUPPLIED	HANDLE ROTATION
CR-19-10-15	PK	NO	UNIVERSAL
CR-19-10-25			COUNTERCLOCKWISE
CR-19-10-35			CLOCKWISE
CR-19-11-15		YES	UNIVERSAL
CR-19-11-25			COUNTERCLOCKWISE
CR-19-11-35			CLOCKWISE
CR-19-20-15	PK / PADLOCK	NO	UNIVERSAL
CR-19-20-25			COUNTERCLOCKWISE
CR-19-20-35			CLOCKWISE
CR-19-21-15		YES	UNIVERSAL
CR-19-21-25			COUNTERCLOCKWISE
CR-19-21-35			CLOCKWISE
CR-19-30-15	DIN (18254)	NO	UNIVERSAL
CR-19-30-25			COUNTERCLOCKWISE
CR-19-30-35			CLOCKWISE
CR-19-32-15		YES	UNIVERSAL
CR-19-32-25			COUNTERCLOCKWISE
CR-19-32-35			CLOCKWISE
CR-19-44-15	BELLCORE ELECTRONICS	YES	UNIVERSAL
CR-19-44-25			COUNTERCLOCKWISE
CR-19-44-35			CLOCKWISE
CR-19-45-15	BELLCORE 216	YES	UNIVERSAL
CR-19-45-25			COUNTERCLOCKWISE
CR-19-45-35			CLOCKWISE
CR-19-46-15	SLOTTED	YES	UNIVERSAL
CR-19-46-25			COUNTERCLOCKWISE
CR-19-46-35			CLOCKWISE
CR-19-47-15	8mm HEX RECESS	YES	UNIVERSAL
CR-19-47-25			COUNTERCLOCKWISE
CR-19-47-35			CLOCKWISE
CR-19-54-15	BELLCORE ELECTRONICS/ PADLOCK	YES	UNIVERSAL
CR-19-54-25			COUNTERCLOCKWISE
CR-19-54-35			CLOCKWISE
CR-19-55-15	BELLCORE 216 / PADLOCK	YES	UNIVERSAL
CR-19-55-25			COUNTERCLOCKWISE
CR-19-55-35			CLOCKWISE
CR-19-56-15	SLOTTED / PADLOCK	YES	UNIVERSAL
CR-19-56-25			COUNTERCLOCKWISE
CR-19-56-35			CLOCKWISE
CR-19-57-15	8mm HEX RECESS/ PADLOCK	YES	UNIVERSAL
CR-19-57-25			COUNTERCLOCKWISE
CR-19-57-35			CLOCKWISE

- EACH HANDLE ACTUATOR INCLUDES: (1) MOUNTING BRACKET, (4) MOUNTING SCREWS, (1) ROD ACTUATOR ASSEMBLY, (2) SHOULDER WASHERS, (2) JAM NUTS, (2) LOCKWASHERS, (2) ROD SCREWS, AND (1) KEY SET IF APPLICABLE

HANDLE PAWL			
PART NUMBER	OFFSET (mm)	GRIP RANGE (mm)	GRIP RANGE (mm) REVERSE ORIENTATION
CR-846-1000-24	0.0	56.5 - 62	
CR-846-1005-24	5	51.5 - 57	61.5 - 67
CR-846-1010-24	10	46.5 - 52	66.5 - 72
CR-846-1015-24	15	41.5 - 47	71.5 - 77
CR-846-1020-24	20	36.5 - 42	76.5 - 82
CR-846-1025-24	25	31.5 - 37	81.5 - 87
CR-846-1030-24	30	26.5 - 32	86.5 - 92
CR-846-1035-24	35	21.5 - 27	91.5 - 97
CR-846-1040-24	40	16.5 - 22	96.5 - 102
CR-846-1045-24	45	11.5 - 17	101.5 - 107
CR-846-1050-24	50	6.5 - 12	106.5 - 112

ROD		
PART NUMBER	COMMENT	MATERIAL
CR-64-1000-50	SEE NOTE 1	6061-T6 ALUMINUM, NATURAL
CR-64-0XXX-50	SEE NOTE 2 & 3	
1) BLANK ROD: LENGTH OF ROD 1000mm, SHIPS WITHOUT 8.5mm MOUNTING HOLE. CUSTOMER TO CUT TO REQUIRED LENGTH AND INSTALL 8.5mm MOUNTING HOLE.		
2) ROD MANUFACTURED TO LENGTHS IN 1mm INCREMENTS, SHIPS READY TO INSTALL		
3) 0XXX = TOTAL ROD LENGTH IN MILLIMETERS. RANGE FROM 300 TO 999 mm (EXAMPLE: CR-64-0750-50 = 750mm LONG EXTRUDED ALUMINUM ROD WITH 8.5mm MOUNTING HOLE)		

ROD MOUNTING HARDWARE			
NAME	PART NUMBER	QUANTITY REQUIRED	MATERIAL
ROD GUIDE	CR-843-01-26	2	C36000 BRASS

ROD END		
PART NUMBER	OFFSET (mm)	MATERIAL
CR-51-30-24	+30	300 SERIES STAINLESS STEEL, PASSIVATED
CR-51-15-24	+15	
CR-50-01-24	0	
CR-52-15-24	-15	
CR-52-30-24	-30	
- COMPARE THE ENCLOSURE ROD GRIP LENGTH TO THE CALCULATED MAXIMUM AND MINIMUM ROD GRIP TO DETERMINE THE AMOUNT OF OFFSET REQUIRED. SELECT THE SMALLEST OFFSET AMOUNT.		

REV	DATE	DRAWN/CHKD	DESCRIPTION
B	25FEB2014	CMS/JCK	PRN: P2014-0383
C	06MAY2014	CMS/BGL	PRN: P2014-0890
D	07JAN2016	CMS/LT	PRN: P2016-0025
E	22MAR2016	CMS/MGG	PRN: P2016-0641
F	14FEB2017	CMS/MSR	PRN: P2017-0369
G	13JUN2017	CMS/RO	PRN: P2017-1406
H	12APR2019	CMS/DMS	PRN: P2019-0802
I	03DEC2019	CMS/MGG	PRN: P2019-2929

MILLIMETERS

ALL DIMENSIONS WITHOUT TOLERANCES ARE FOR REFERENCE ONLY.

THIRD ANGLE PROJECTION

A3 PAPER SIZE

SHEET 2 OF 4

NOTES:
 A. *L* (LENGTH OF THE CENTERLINE OF ACTUATOR SHAFT TO EDGE OF ENCLOSURE FRAME) IS USED TO DETERMINE ROD LENGTH IN FORMULA SHOWN ON SHEET 1 OF THIS DRAWING.

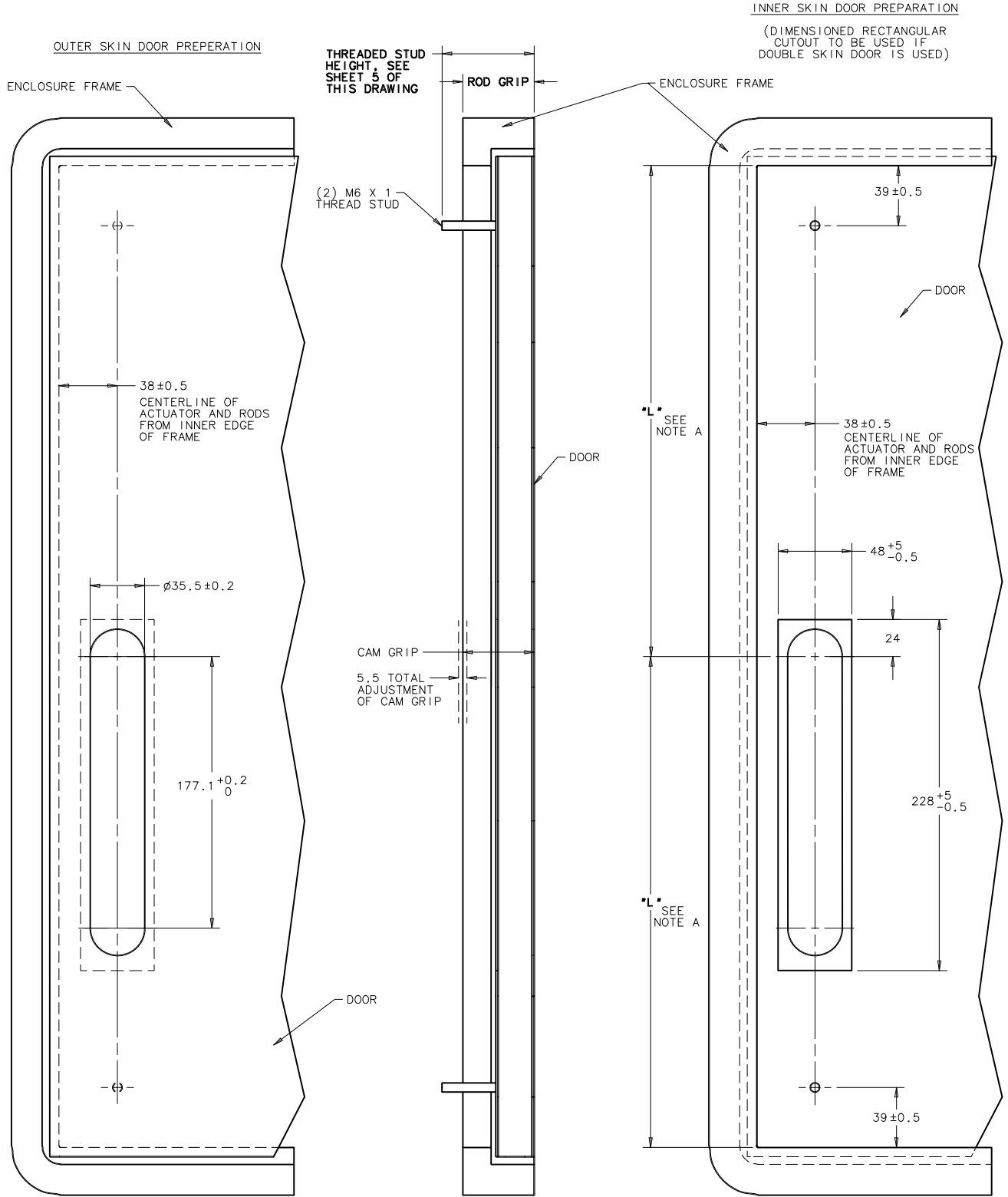

REV	DATE	DRAWN/CHKD	DESCRIPTION
B	25FEB2014	CMS/JCK	PRN: P2014-0383
C	06MAY2014	CMS/BGL	PRN: P2014-0890
D	07JAN2016	CMS/LT	PRN: P2016-0025
E	22MAR2016	CMS/MGG	PRN: P2016-0641
F	14FEB2017	CMS/MSR	PRN: P2017-0369
G	13JUN2017	CMS/RO	PRN: P2017-1406
H	12APR2019	CMS/DMS	PRN: P2019-0802
I	03DEC2019	CMS/MGG	PRN: P2019-2929

MILLIMETERS

ALL DIMENSIONS WITHOUT TOLERANCES ARE FOR REFERENCE ONLY.

THIRD ANGLE PROJECTION

A3 PAPER SIZE

SHEET 3 OF 4

INSTALLATION PROCEDURE:

- 1) INSERT HANDLE ACTUATOR INTO PANEL CUT OUT. POSITION MOUNTING BRACKET ON OPPOSITE SIDE OF PANEL. FASTEN WITH LOWER MOUNTING SCREWS (DO NOT TORQUE TO TIGHTEN).
- 2) WITH HANDLE IN OPEN POSITION, SLIDE ROD ACTUATOR ONTO THE THREADED SHAFT. ALIGN HOLES IN THE ROD ACTUATOR WITH HOLES OF THE MOUNTING BRACKET AND HANDLE ACTUATOR. PLACE THE SHOULDER WASHERS INTO THE ALIGNED HOLES AND THREAD THE REMAINING MOUNTING SCREWS. TORQUE ALL MOUNTING SCREWS TO 6.0-6.5 N-m.
- 3) INSTALL, IN ORDER, THE FOLLOWING ONTO THE THREADED SHAFT AS SHOWN : JAM NUT, LOCKWASHER, CAM, LOCKWASHER, JAM NUT. ADJUST TO DESIRED GRIP AND TIGHTEN BOTH JAM NUTS.
- 4) ROTATE AND LATCH HANDLE ACTUATOR.
- 5) HAND THREAD ROD GUIDES ONTO THREADED STUDS AT TOP AND BOTTOM OF DOOR, UNTIL IT BECOMES DIFFICULT TO ROTATE BY HAND. ROD GUIDES HAVE A PREVAILING TORQUE FEATURE. (THREADED STUDS ARE SUPPLIED BY CUSTOMER)
- 6) INSERT THE TAB ON ROD END INTO THE SLOT OF ROD. ROTATE THE ROD END TO JOIN. PLACE THEM ONTO ROD GUIDE USING THE LARGE DIAMETER OF THE KEYHOLE SLOT. SLIDE THE ROD TOWARD THE HANDLE ACTUATOR.
- 7) PLACE THE 8.5mm MOUNTING HOLE ON THE ROD OVER EXTRUDED THREADED HUB ON THE ROD ACTUATOR. FASTEN WITH ROD SCREW. TORQUE TO 4.5-5.0 N-m.
- 8) REPEAT STEPS 6 AND 7 FOR REMAINING ROD AND ROD END.
- 9) ADJUST THE ROD GRIP BY ADJUSTING THE ROD GUIDE WITH A 10mm HEXAGON HAND TOOL.

INTERIOR VIEW OF DOUBLE THICKNESS DOOR
INSTALLATION WITH FULL ACCESS HOLE

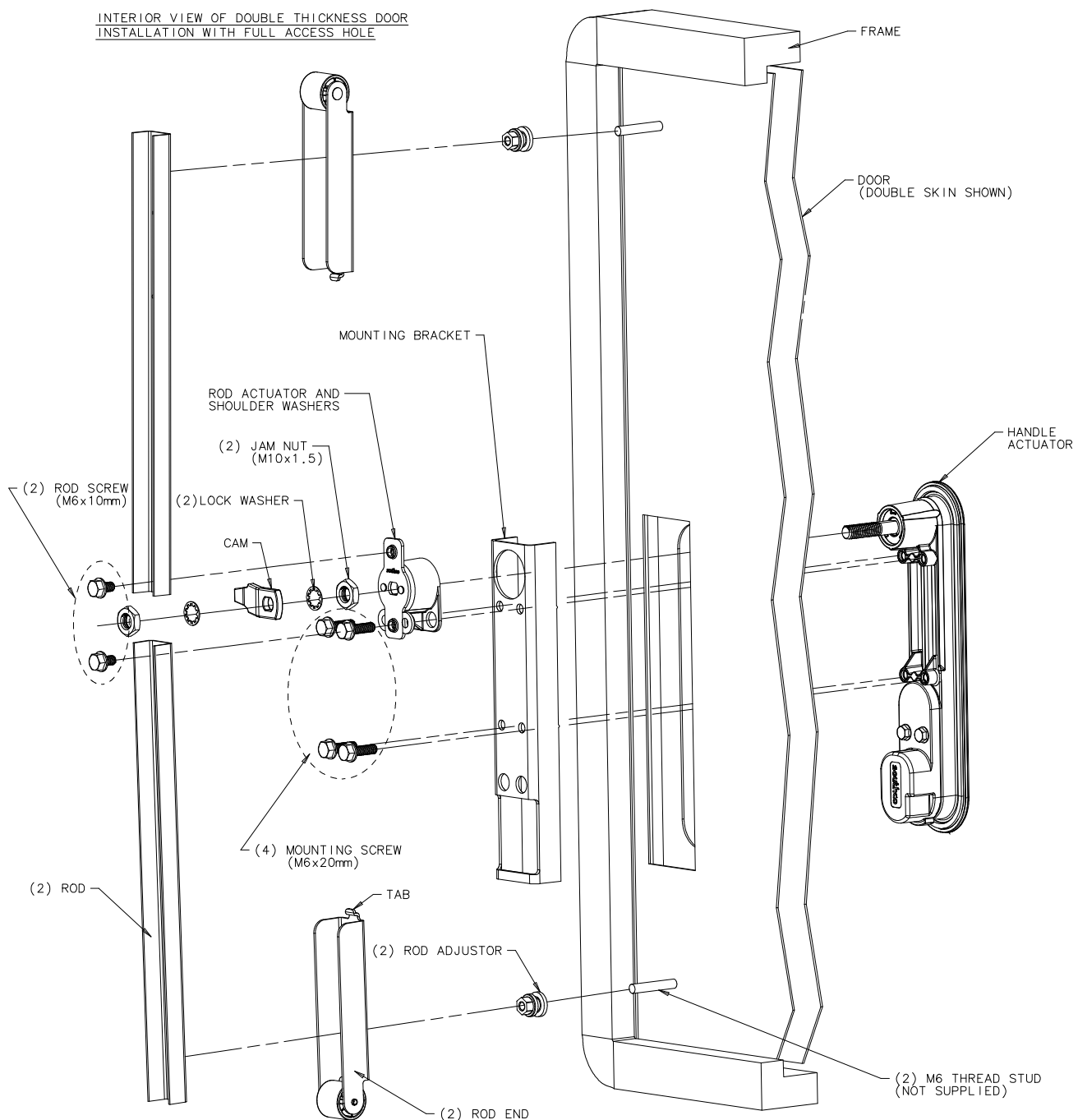

REV	DATE	DRAWN/CHKD	DESCRIPTION
B	25FEB2014	CMS/JCK	PRN: P2014-0383
C	06MAY2014	CMS/BGL	PRN: P2014-0890
D	07JAN2016	CMS/LT	PRN: P2016-0025
E	22MAR2016	CMS/MGG	PRN: P2016-0641
F	14FEB2017	CMS/MSR	PRN: P2017-0369
G	13JUN2017	CMS/RO	PRN: P2017-1406
H	12APR2019	CMS/DMS	PRN: P2019-0802
I	03DEC2019	CMS/MGG	PRN: P2019-2929

MILLIMETERS

ALL DIMENSIONS WITHOUT TOLERANCES ARE FOR REFERENCE ONLY.

THIRD ANGLE PROJECTION

A3 PAPER SIZE

SHEET 4 OF 4

MATERIAL & FINISH (RoHS COMPLIANT):

ACTUATOR AND HARDWARE

HANDLE ACTUATOR ASSEMBLY: STAINLESS STEEL, PASSIVATED, RUBBER, ZINC DIE CAST, POWDER COAT
 ROD ACTUATOR ASSEMBLY: 300 SERIES STAINLESS STEEL, PASSIVATED, ZINC DIE CAST + SEALER, ACETEL
 MOUNTING BRACKET: 300 SERIES STAINLESS STEEL, PASSIVATED
 MOUNTING SCREWS: 300 SERIES STAINLESS STEEL, PASSIVATED
 GASKETS: THERMOPLASTIC ELASTOMER
 CAM: 300 SERIES STAINLESS STEEL, PASSIVATED
 JAM NUTS: 300 SERIES STAINLESS STEEL, PASSIVATED
 LOCKWASHERS: 300 SERIES STAINLESS STEEL, PASSIVATED
 SHOULDER WASHERS: C36000 BRASS

ROD & ROD END

ROD: 6061-T6 EXTRUDED ALUMINUM
 ROD END: 300 SERIES STAINLESS STEEL, PASSIVATED
 ROLLER: NYLON 6/6
 ROD GUIDE: C36000 BRASS
 ROD SCREWS: 300 SERIES STAINLESS STEEL, PASSIVATED

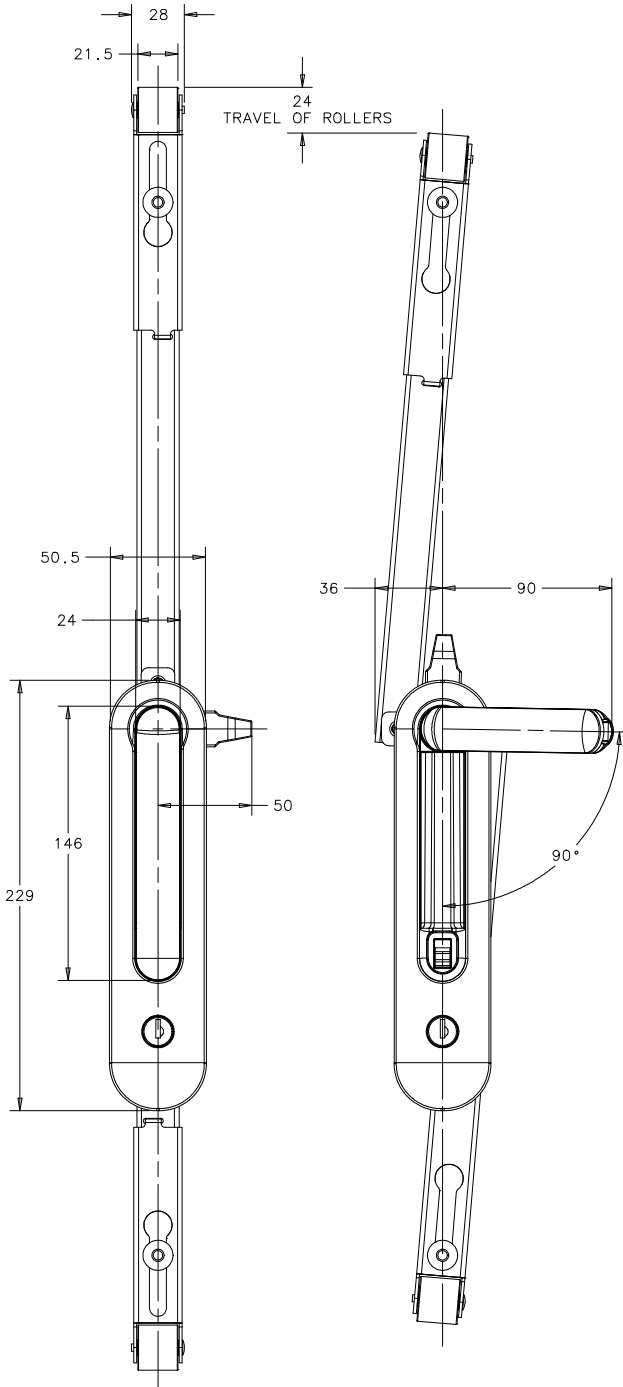

FRONT VIEW (CLOSED)

FRONT VIEW (OPEN)

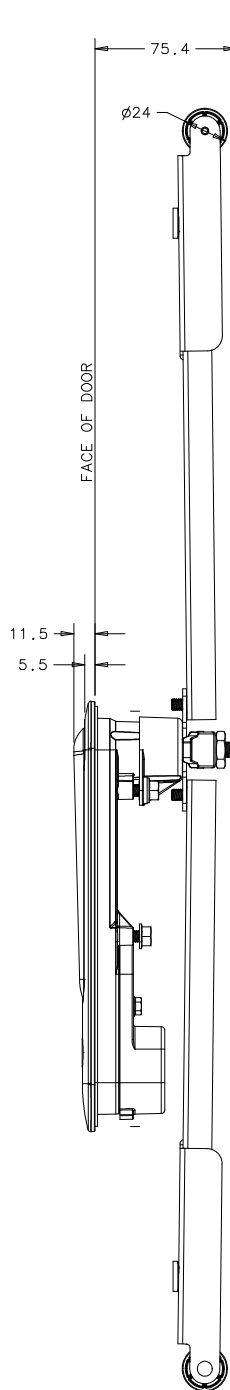

SIDE VIEW (CLOSED)

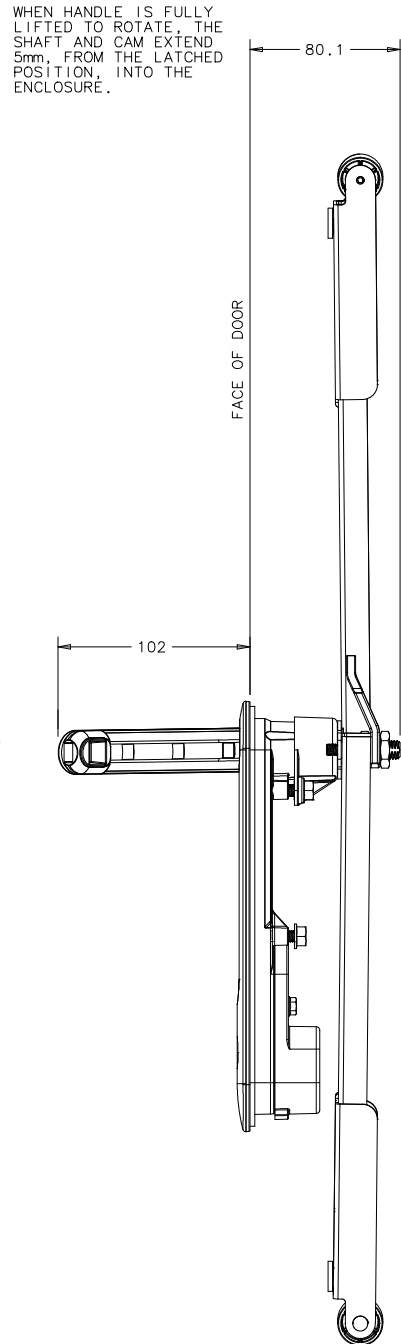

SIDE VIEW (OPEN)