

REVISION HISTORY

REV	DATE	BY	DESCRIPTION
D	03JUN2024	MTS/MGG	PRN: P2024-0952

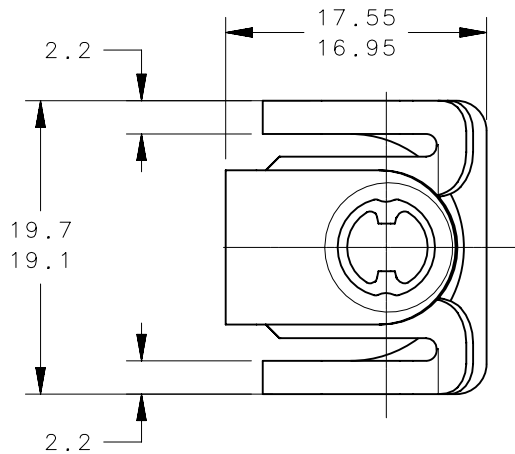

SCALE 1:1

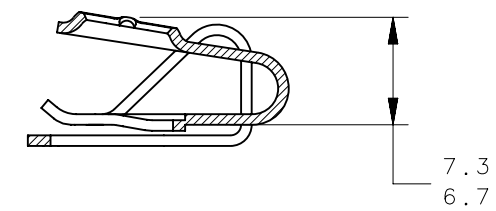
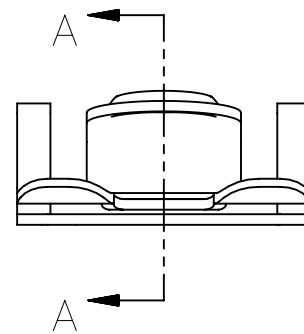
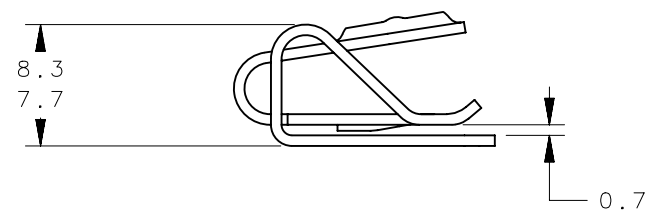

SECTION A-A

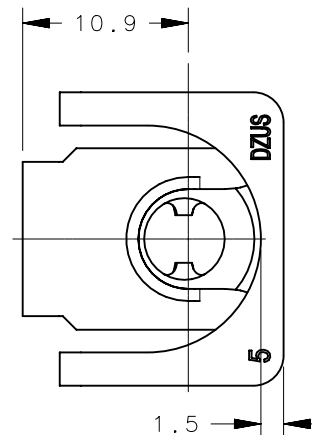

NOTES:

- MATERIAL: CARBON STEEL -CSA 70  
HEAT TREATED TO 505-555 Hv.
- SUITABLE FOR PANEL THICKNESS RANGE:  
0.7mm - 2.2mm.

D2-535-330-190	RECEPTACLE	SEE NOTE 1	ZINC, BRIGHT CHROMATE
D2-535-330-130	RECEPTACLE		SILVER ORGANIC
SOUTHCO PART NUMBER	TYPE OF COMPONENT	MATERIAL	FINISH

THIRD ANGLE PROJECTION		 CONNECT • CREATE • INNOVATE	
MILLIMETERS [IN]			
TOLERANCES UNLESS OTHERWISE NOTED		DESCRIPTION RAPIER # 5 SLIP ON PLATE	
ALL DIMENSIONS WITHOUT TOLERANCES ARE FOR REFERENCE ONLY.		SIZE A4	SYSTEM NX
PROPRIETARY ITEM <small>EXCEPT FOR USES EXPRESSLY GRANTED IN WRITING, INFORMATION DISCLOSED HEREON IS CONFIDENTIAL AND ALL RIGHTS, PATENT AND OTHERWISE, ARE RESERVED BY SOUTHCO, INC.</small>		DWG NO. J-D2-535-330-130	
PER ASME Y14.5M-2009		DRAWN BY MJW	DATE 07OCT2005
		SCALE 2:1	SHEET 1 OF 1