

REVISION HISTORY			
REV	DATE	BY	DESCRIPTION
E	16JUN2023	DPZ/CMS	PRN: P2023-0909

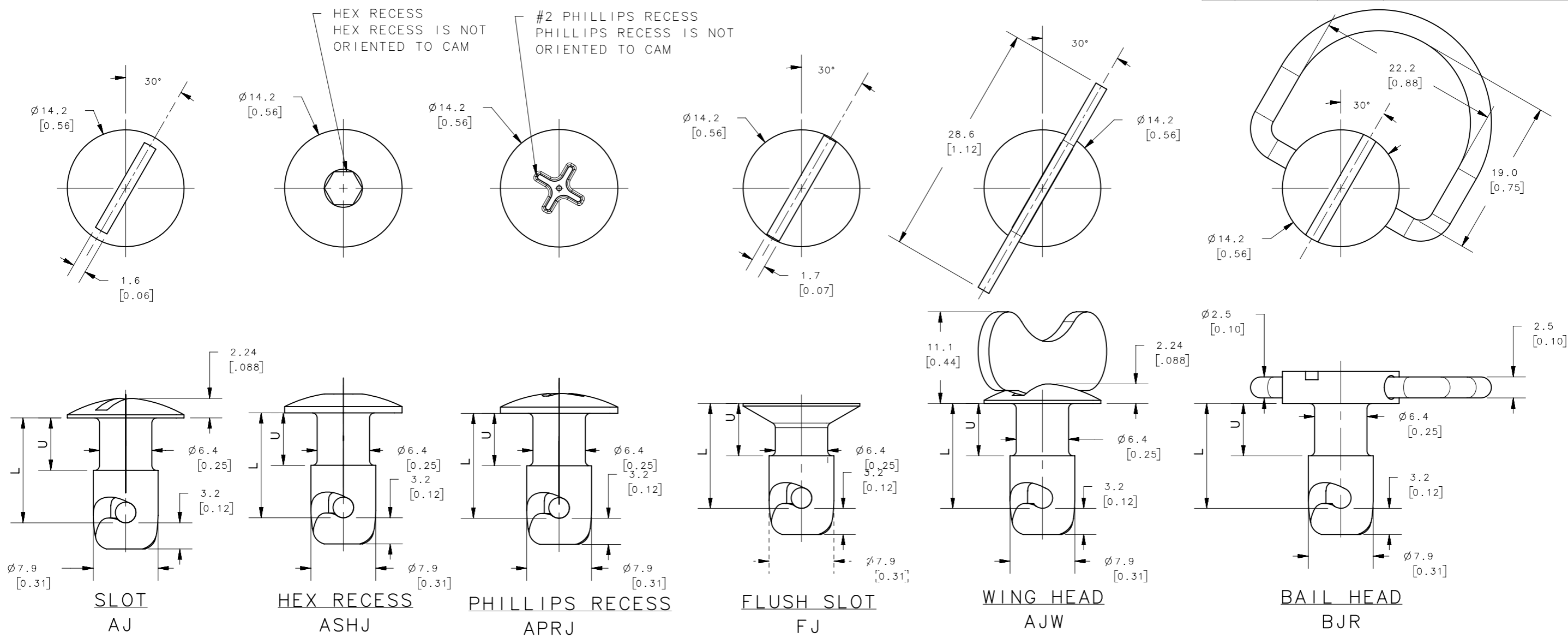

SELECTION TABLE

PART NUMBER

LENGTH

ENTER NUMBER FROM SELECTION TABLE



K	U	L	K	U	L	K	U	L	K	U	L
25	1.91 [0.075]	6.35 [0.250]	85	12.70 [0.500]	21.59 [0.850]	145	17.78 [0.700]	36.83 [1.450]	205	17.78 [0.700]	52.07 [2.050]
30	3.18 [0.125]	7.62 [0.300]	90	15.24 [0.600]	22.86 [0.900]	150	17.78 [0.700]	38.10 [1.500]	210	17.78 [0.700]	53.34 [2.100]
35	3.18 [0.125]	8.89 [0.350]	95	15.24 [0.600]	24.13 [0.950]	155	17.78 [0.700]	39.37 [1.550]	215	17.78 [0.700]	54.61 [2.150]
40	4.83 [0.190]	10.16 [0.400]	100	17.78 [0.700]	25.40 [1.000]	160	17.78 [0.700]	40.64 [1.600]	220	17.78 [0.700]	55.88 [2.200]
45	4.83 [0.190]	11.43 [0.450]	105	17.78 [0.700]	26.67 [1.050]	165	17.78 [0.700]	41.91 [1.650]	225	17.78 [0.700]	57.15 [2.250]
50	6.35 [0.250]	12.70 [0.500]	110	17.78 [0.700]	27.94 [1.100]	170	17.78 [0.700]	43.18 [1.700]	230	17.78 [0.700]	58.42 [2.300]
55	6.99 [0.275]	13.97 [0.550]	115	17.78 [0.700]	29.21 [1.150]	175	17.78 [0.700]	44.45 [1.750]	235	17.78 [0.700]	59.69 [2.350]
60	7.62 [0.300]	15.24 [0.600]	120	17.78 [0.700]	30.48 [1.200]	180	17.78 [0.700]	45.72 [1.800]	240	17.78 [0.700]	60.96 [2.400]
65	8.89 [0.350]	16.51 [0.650]	125	17.78 [0.700]	31.75 [1.250]	185	17.78 [0.700]	46.99 [1.850]	245	17.78 [0.700]	62.23 [2.450]
70	10.16 [0.400]	17.78 [0.700]	130	17.78 [0.700]	33.02 [1.300]	190	17.78 [0.700]	48.26 [1.900]	250	17.78 [0.700]	63.50 [2.500]
75	10.16 [0.400]	19.05 [0.750]	135	17.78 [0.700]	34.29 [1.350]	195	17.78 [0.700]	49.53 [1.950]			
80	12.70 [0.500]	20.32 [0.800]	140	17.78 [0.700]	35.56 [1.400]	200	17.78 [0.700]	50.80 [2.000]			

HEAD STYLE

- AJ SLOT
- ASHJ HEX RECESS
- APRJ PHILIPS RECESS
- FJ FLUSH SLOT
- AJW WING HEAD
- BJR BAIL HEAD

MATERIAL/FINISH

NO SUFFIX: STEEL ZINC PLATED WITH CLEAR CHROMATE FINISH
 EX: D4-AJ5-30
 SS: STAINLESS STEEL, HEAT TREATED, PASSIVATED
 EX: D4-AJ5-30SS
 FOR NON STANDARD FINISHES, REFER TO SOUTHCO SPECIFICATION
 J-D5-0-3 EX: D4-AJ5-30CBB

NOTE:

1. D4-H5-K IS SAME AS HARTWELL-DZUS H5-K
 EX: D4-AJ5-30 IS SAME HARTWELL-DZUS AS AJ5-30

THIRD ANGLE PROJECTION				
	TOLERANCES UNLESS OTHERWISE NOTED		DESCRIPTION	
ALL DIMENSIONS WITHOUT TOLERANCES ARE FOR REFERENCE ONLY.		QUARTER TURN FASTENER, D4-H5		
PROPRIETARY ITEM	PER ASME Y14.5M-1994	SIZE A3	SYSTEM NX	DWG NO. J-D4-H5-K
EXCEPT FOR USES EXPRESSLY GRANTED IN WRITING, INFORMATION DISCLOSED HEREON IS CONFIDENTIAL AND ALL RIGHTS, PATENT AND OTHERWISE, ARE RESERVED BY SOUTHCO, INC.		DRAWN BY YGC	DATE 09 DEC 2010	SCALE 2.5:1 SHEET 1 OF 1