

SPRING SETS TO BE FLAT FOR 270° MIN

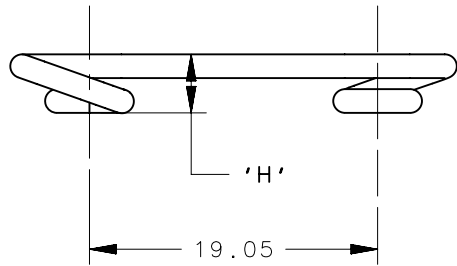

REVISION HISTORY			
REV	DATE	BY	DESCRIPTION
B	09MAY2023	BVM/DMS	PRN: P2023-0845

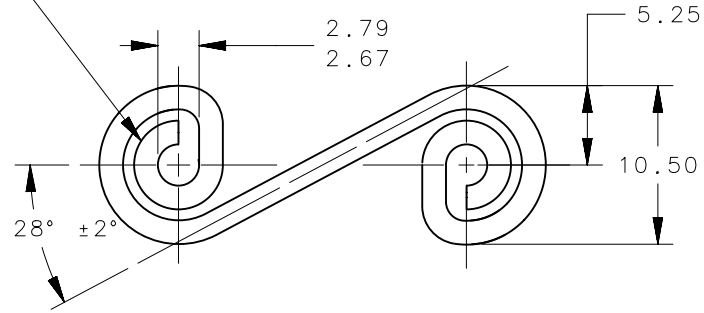
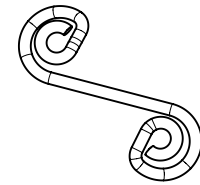

SCALE 1:1

D4-S4-300	7.62	0.300	HIGH TENSILE STEEL	ZINC PLATE BRIGHT CHROMATE	Ø1.57 (0.062) WIRE
D4-S4-275	6.98	0.275			
D4-S4-250	6.35	0.250			
D4-S4-225	5.72	0.225			
D4-S4-200	5.08	0.200			
D4-S4-175	4.45	0.175			
D4-S4-150	3.81	0.150			
PART NUMBER	METRIC	INCHES	MATERIAL	FINISH	FORM
	H' DIM.				
D4-S4-275SS	6.98	0.275	STAINLESS STEEL	PASSIVATE	Ø1.57 (0.062) WIRE
D4-S4-250SS	6.35	0.250			
D4-S4-225SS	5.72	0.225			
D4-S4-200SS	5.08	0.200			
D4-S4-175SS	4.45	0.175			
D4-S4-150SS	3.81	0.150			
PART NUMBER	METRIC	INCHES	MATERIAL	FINISH	FORM
	H' DIM.				

	THIRD ANGLE PROJECTION				
	MILLIMETERS [IN]				
	TOLERANCES UNLESS OTHERWISE NOTED	DESCRIPTION			
SURFACE AREA	ALL DIMENSIONS WITHOUT TOLERANCES ARE FOR REFERENCE ONLY.	SPRING TYPE S4			
VOLUME		SIZE	SYSTEM	DWG NO.	
PROPRIETARY ITEM		A4	NX	J-D4-S4	
EXCEPT FOR USES EXPRESSLY GRANTED IN WRITING, INFORMATION DISCLOSED HEREON IS CONFIDENTIAL AND ALL RIGHTS, PATENT AND OTHERWISE, ARE RESERVED BY SOUTHCO, INC.	PER ASME Y14.5M-1994	DRAWN BY	DATE	SCALE	SHEET
		CW/MJS	07JAN2008	2:1	1 OF 1