

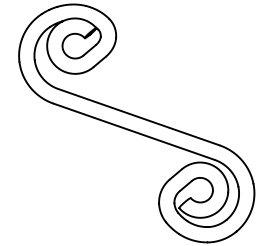

REVISION HISTORY			
REV	DATE	BY	DESCRIPTION
C	08MAY2023	BVM/DMS	PRN: P2023-0816

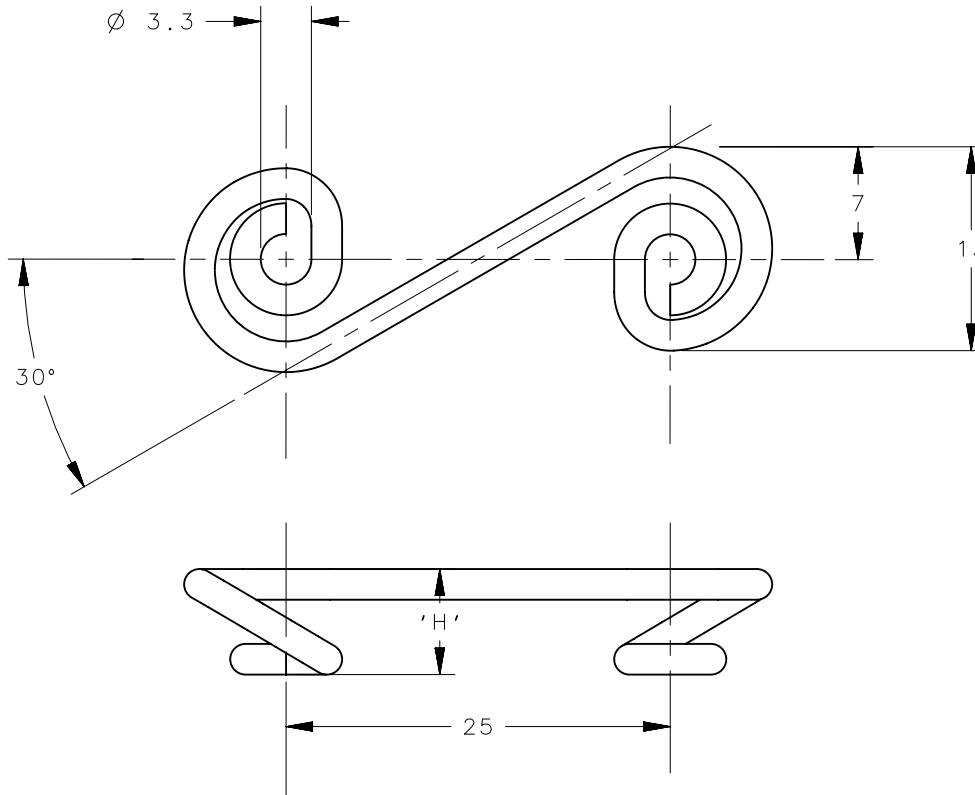
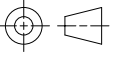

SCALE 1:1

PART NUMBER	'H' DIM
D4-S5-175	4.5
D4-S5-200	5.0
D4-S5-225	5.8
D4-S5-250	6.4
D4-S5-275	7.0
D4-S5-300	8.0
D4-S5-325	8.5

D4-S5-XXX	SPRING	SPRING STEEL	ZINC PLATE		
D4-S5-XXXSS	SPRING	STAINLESS STEEL	CLEAN		
PART NUMBER	TYPE OF COMPONENT	MATERIAL	FINISH		
	THIRD ANGLE PROJECTION 	 CONNECT • CREATE • INNOVATE			
	MILLIMETERS [IN]				
	TOLERANCES UNLESS OTHERWISE NOTED	DESCRIPTION			
SURFACE AREA	ALL DIMENSIONS WITHOUT TOLERANCES ARE FOR REFERENCE ONLY.	SPRING - S5 TYPE			
VOLUME		SIZE	SYSTEM	DWG NO.	
PROPRIETARY ITEM	PER ASME Y14.5M-1994	A4	NX	J-D4-S5-XXX	
EXCEPT FOR USES EXPRESSLY GRANTED IN WRITING, INFORMATION DISCLOSED HEREON IS CONFIDENTIAL AND ALL RIGHTS, PATENT AND OTHERWISE, ARE RESERVED BY SOUTHCO, INC.		DRAWN BY	DATE	SCALE	SHEET
		MJW	26JUL2007	2:1	1 OF 1