

southco

PROPRIETARY ITEM - EXCEPT FOR USES EXPRESSLY GRANTED IN WRITING INFORMATION DISCLOSED HEREON IS CONFIDENTIAL AND ALL RIGHTS PATENT AND OTHERWISE ARE RESERVED BY SOUTHCO, INC.

SLIP-ON SPRING PLATE ASSEMBLY
SL4 SERIES

DATE	DRAWN	CHKD	SCALE	DRAWING NUMBER
12DEC2007	CW	MJS	2:1	J-D4-SL4

REV	DATE	DRAWN/CHKD	DESCRIPTION	PART NUMBER	MATERIAL	FINISH			
			INITIAL DRAWING RELEASE	SEE TABLE 1					

MILLIMETERS
ALL DIMENSIONS WITHOUT TOLERANCES ARE FOR REFERENCE ONLY.

THIRD ANGLE PROJECTION

A3 PAPER SIZE

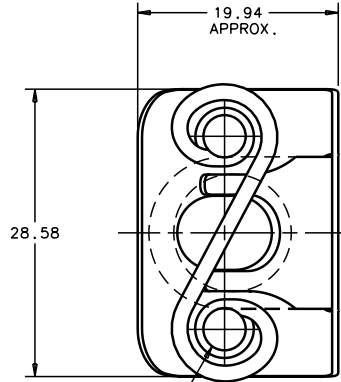

2X RIVET

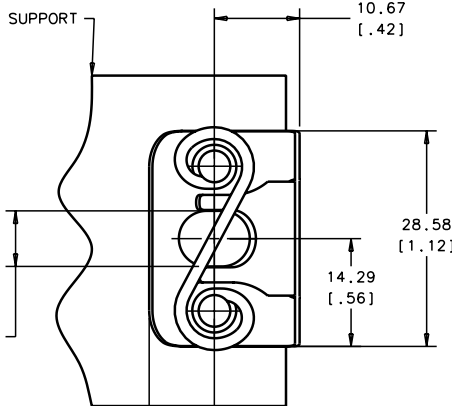

8.64 [.34]

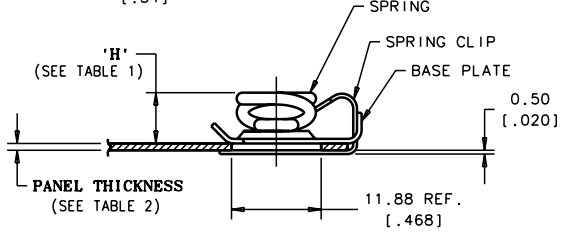

PANEL PREPARATION
(SCALE: 1.5:1)

TABLE 1

ITEM	QTY	PART NO.	MATERIAL	FINISH	'H'		'H'+0.020 INCHES	'H'+0.51 METRIC
					INCHES	METRIC		
ASSEMBLY	--	D4-SL4-280	--	--				
BASE PLATE	1	--	CARBON STEEL					
SPRING CLIP	1	--	CARBON SPRING STEEL	ZINC PLATE BRIGHT CHROMATE	0.260	6.60	0.280	7.11
SPRING	1	--	HIGH TENSILE STEEL					
RIVET	2	--	--	--				
ASSEMBLY	--	D4-SL4-305	--	--				
BASE PLATE	1	--	CARBON STEEL					
SPRING CLIP	1	--	CARBON SPRING STEEL	ZINC PLATE BRIGHT CHROMATE	0.285	7.24	0.305	7.75
SPRING	1	--	HIGH TENSILE STEEL					
RIVET	2	--	--	--				
ASSEMBLY	--	D4-SL4-330	--	--				
BASE PLATE	1	--	CARBON STEEL					
SPRING CLIP	1	--	CARBON SPRING STEEL	ZINC PLATE BRIGHT CHROMATE	0.310	7.87	0.330	8.38
SPRING	1	--	HIGH TENSILE STEEL					
RIVET	2	--	--	--				

TABLE 2

PART NO.	PANEL THICKNESS			
	MINIMUM		MAXIMUM	
	INCHES	MM	INCHES	MM
D4-SL4-XXX	0.036	0.91	0.128	3.25

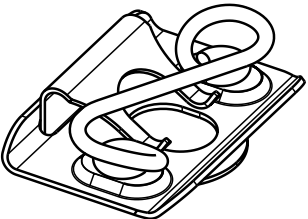

ISOMETRIC VIEW