

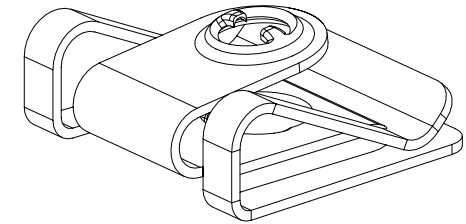

REVISION HISTORY			
REV	DATE	BY	DESCRIPTION
C	27MAR2014	MWC/YGC	PRN: P2014-0731

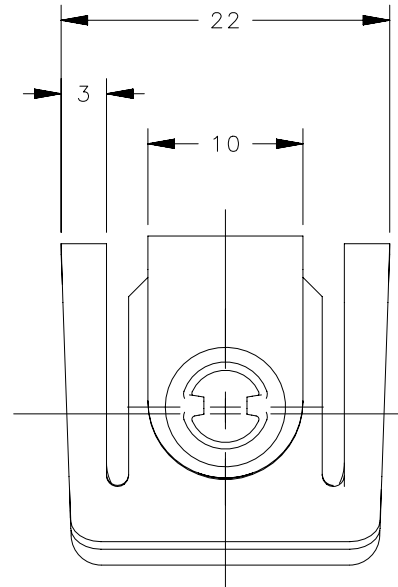
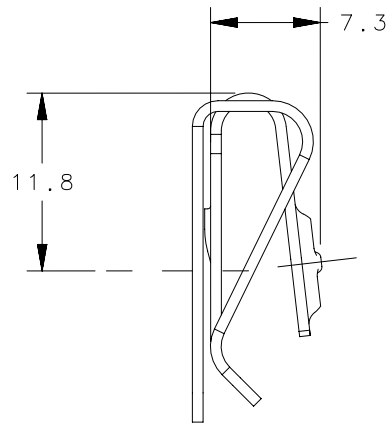

NOTES:

- 1) PANEL THICKNESS TO 0.70 TO 2.50
- 2) PANEL PREPARATION HOLE $\varnothing 8.00$
- 3) DISTANCE FROM PRESENTATION HOLE TO EDGE OF PANEL 10.00 MAX.

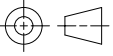
D8-334-300-131	RECEPTACLE	CARBON STEEL	ZINC PHOSPHATE - BLACK
D8-334-300-130	RECEPTACLE	CARBON STEEL	ZINC PHOSPHATE - SILVER
D8-334-300-121	RECEPTACLE	CARBON STEEL	SILVER GEOMET
PART NUMBER	TYPE OF COMPONENT	MATERIAL	FINISH

	THIRD ANGLE PROJECTION 	 CONNECT • CREATE • INNOVATE	
	MILLIMETERS [IN]		
SURFACE AREA	TOLERANCES UNLESS OTHERWISE NOTED	DESCRIPTION PANEX SIZE 4 SLIP ON RECEPTACLE	
VOLUME	ALL DIMENSIONS WITHOUT TOLERANCES ARE FOR REFERENCE ONLY.	SIZE A4	SYSTEM NX
PROPRIETARY ITEM EXCEPT FOR USES EXPRESSLY GRANTED IN WRITING, INFORMATION DISCLOSED HEREON IS CONFIDENTIAL AND ALL RIGHTS, PATENT AND OTHERWISE, ARE RESERVED BY SOUTHCO, INC.	PER ASME Y14.5M-1994	DWG NO. J-D8-334-300	
		DRAWN BY MJW	DATE 24MAR2009
		SCALE 2:1	SHEET 1 OF 1