

REVISION HISTORY			
REV	DATE	BY	DESCRIPTION
B	28JUN2019	ZAA/MGG	PRN: P2019-1652

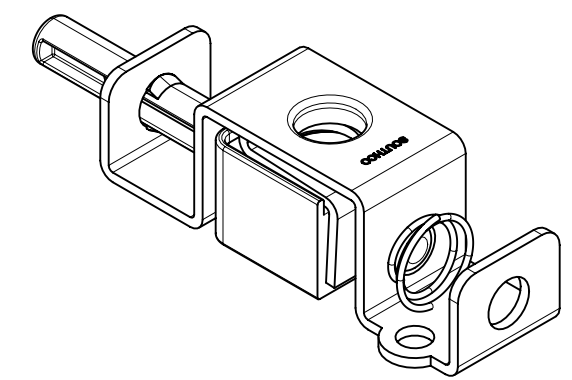
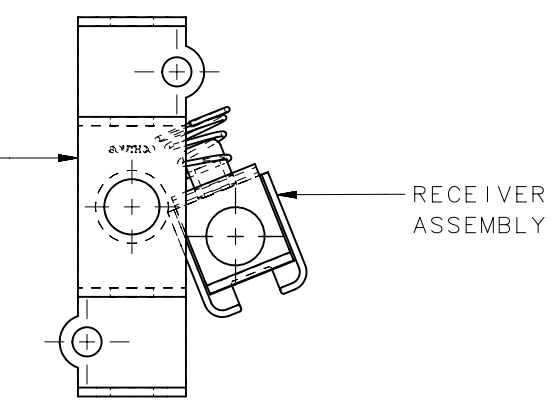
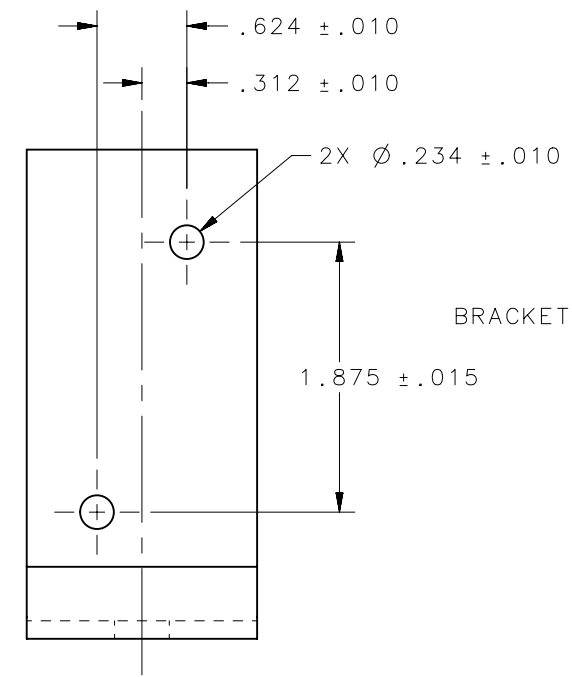
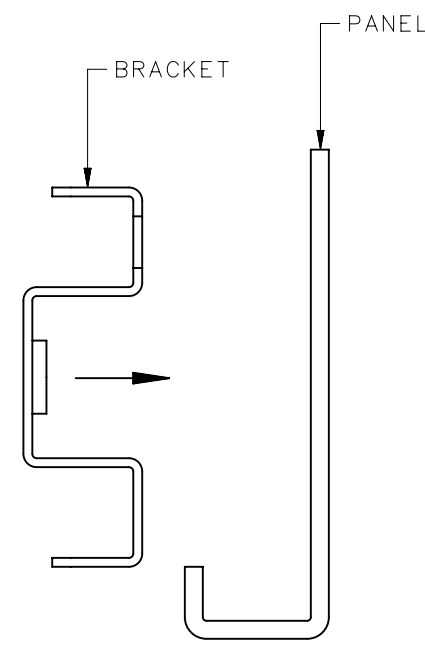

ASSEMBLED
SCALE 1:1

SLIDE RECEIVER INTO
SIDE OF UPPER BRACKET

BRACKET INSTALLATION:
MOUNT BRACKETS ON INSIDE
SURFACE OF YOUR PANEL USING
STUDS, WELDS M5(N_o10) SCREWS
Ø5 (.188)

PANEL PREPARATION

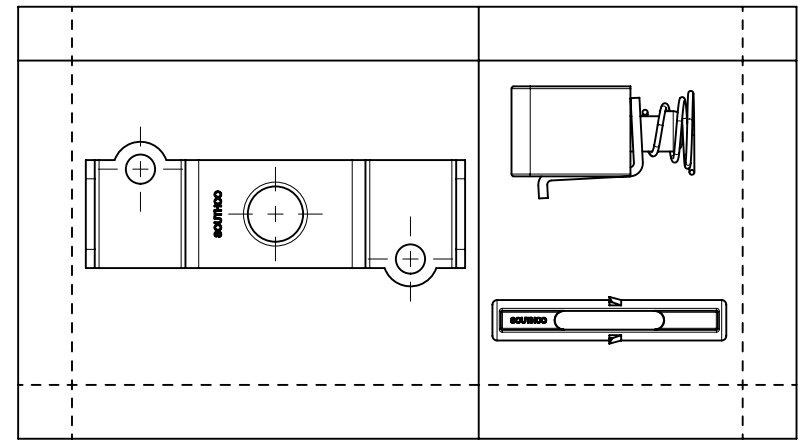
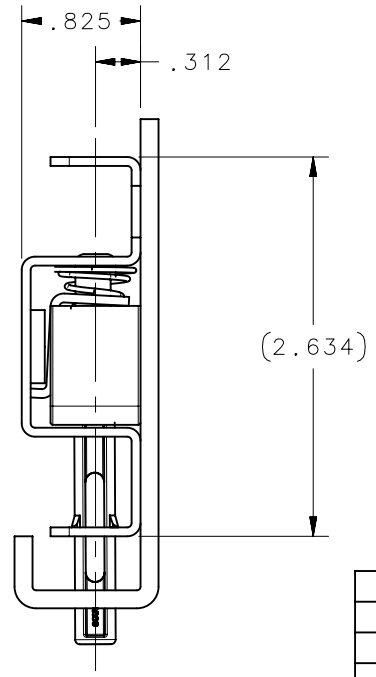
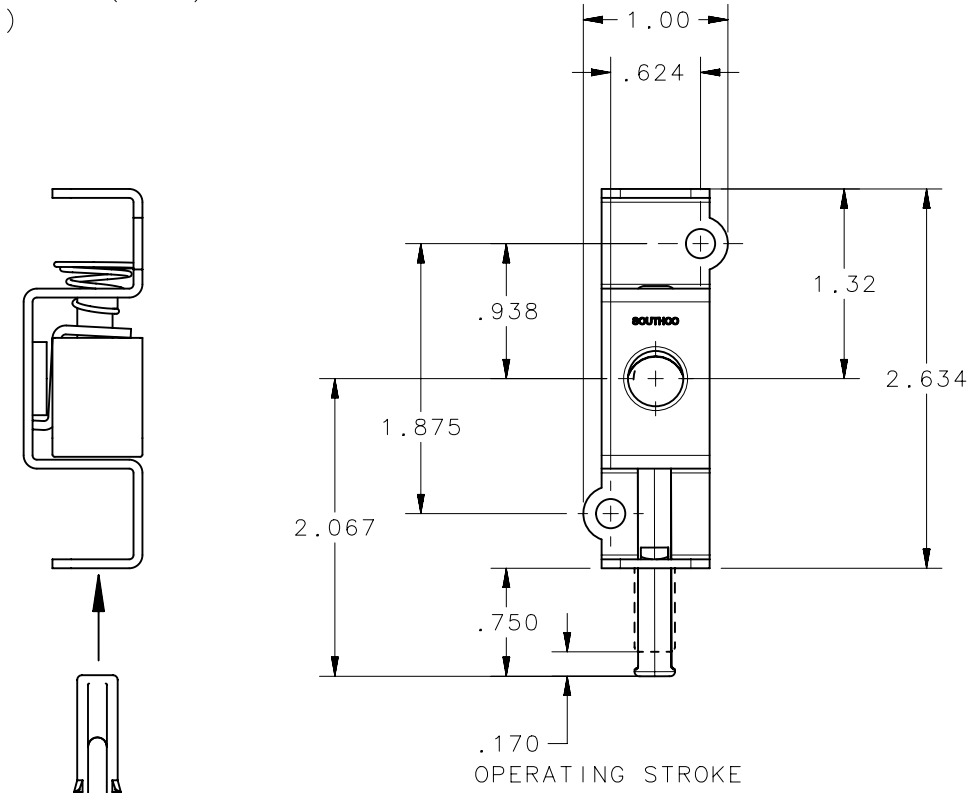

AS PACKAGED

ACTUATOR BUTTON
SNAP-IN ACTUATOR BUTTON

NOTE:
A. THIS ASSEMBLY CAN BE MOUNTED NEAR
EDGE OR REMOTE (SINGLE OR TWO POINT).

NO.	PART NUMBER	QTY	TYPE OF COMPONENT	MATERIAL	FINISH	GENERAL NOTES
4	E2-93-102	1	SUB-ASSEMBLY	-	-	
3	-	1	BRACKET	STEEL	ZINC PLATE	
2	-	1	RECEIVER SUB-ASSEMBLY	-	-	
1	-	1	BUTTON	POLYESTER	WHITE	

THIRD ANGLE PROJECTION					
INCHES [MM]					
SURFACE AREA		TOLERANCES UNLESS OTHERWISE NOTED		DESCRIPTION PACKAGED E2 LATCH (REMOTE LATCHING)	
VOLUME		ALL DIMENSIONS WITHOUT TOLERANCES ARE FOR REFERENCE ONLY.			
PROPRIETARY ITEM		SIZE	SYSTEM	DWG NO.	
EXCEPT FOR USES EXPRESSLY GRANTED IN WRITING, INFORMATION DISCLOSED HEREON IS CONFIDENTIAL AND ALL RIGHTS, PATENT AND OTHERWISE, ARE RESERVED BY SOUTHCO, INC.		B	NX	J-E2-93-102	
PER ASME Y14.5M-1994		DRAWN BY		DATE	SCALE
		NTC/AJH		21MAY2002	0.75:1
				SHEET	1 OF 1