

REVISION HISTORY			
REV	DATE	BY	DESCRIPTION
R	13JUN2024	BVM/CRM	PRN: P2024-1033

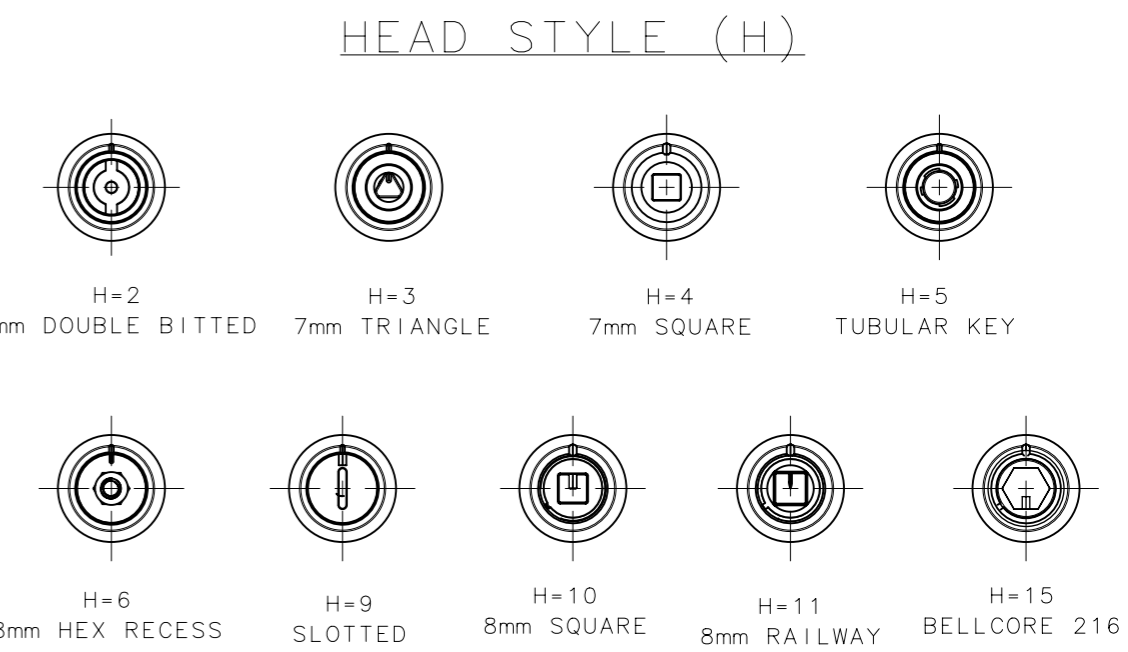

HEAD STYLE	KEY PART NUMBER
3mm DOUBLE-BIT	E3-2-1
7mm TRIANGLE	E3-3-1
7mm SQUARE RECESS	E3-4-1
TUBULAR KEY	E3-5-15
8mm HEX RECESS	NOT SUPPLIED BY SOUTHCO
8mm RAILWAY	NOT SUPPLIED BY SOUTHCO
BELLCORE 216	E3-12-1
3mm SLOTTED RECESS	NOT SUPPLIED BY SOUTHCO

KEYS TO BE ORDERED SEPARATELY

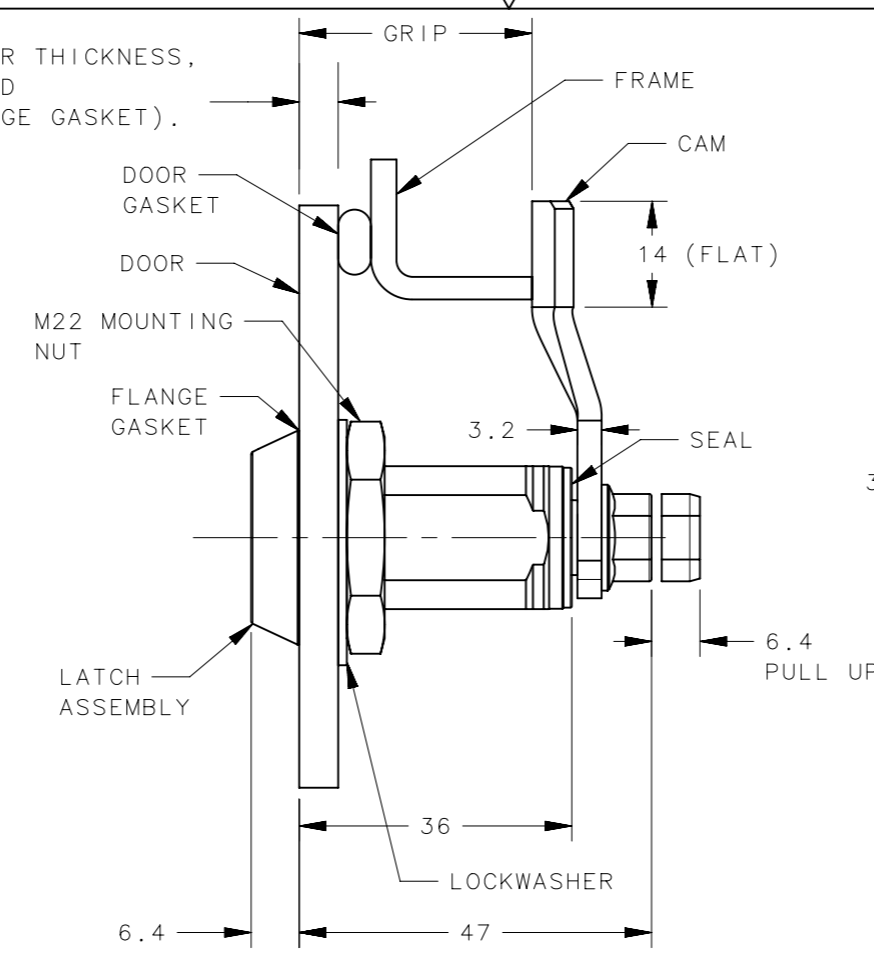
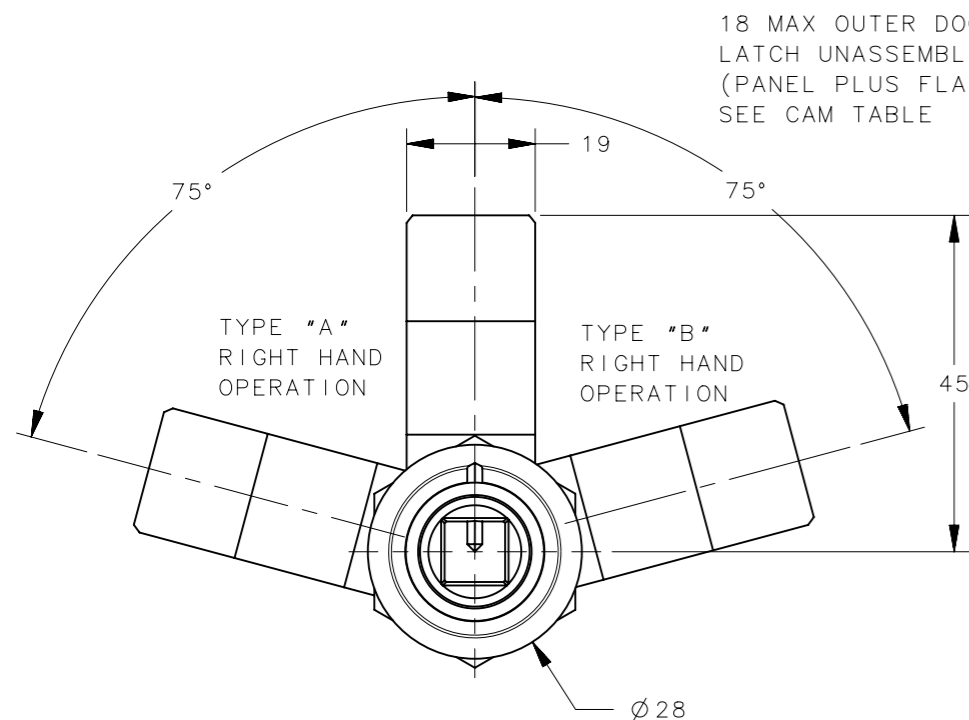
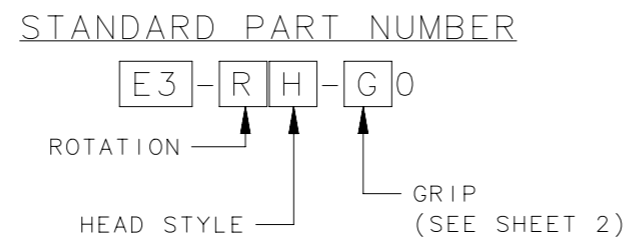

- ROTATION:
- 10 - LATCH SHIPPED ASSEMBLED, TYPE A (TURN CLOCKWISE TO LATCH)
 - 12 - LATCH SHIPPED UNASSEMBLED, TYPE A (TURN CLOCKWISE TO LATCH)
 - 27 - LATCH SHIPPED ASSEMBLED, TYPE B (TURN COUNTERCLOCKWISE TO LATCH)
 - 29 - LATCH SHIPPED UNASSEMBLED, TYPE B (TURN COUNTERCLOCKWISE TO LATCH)

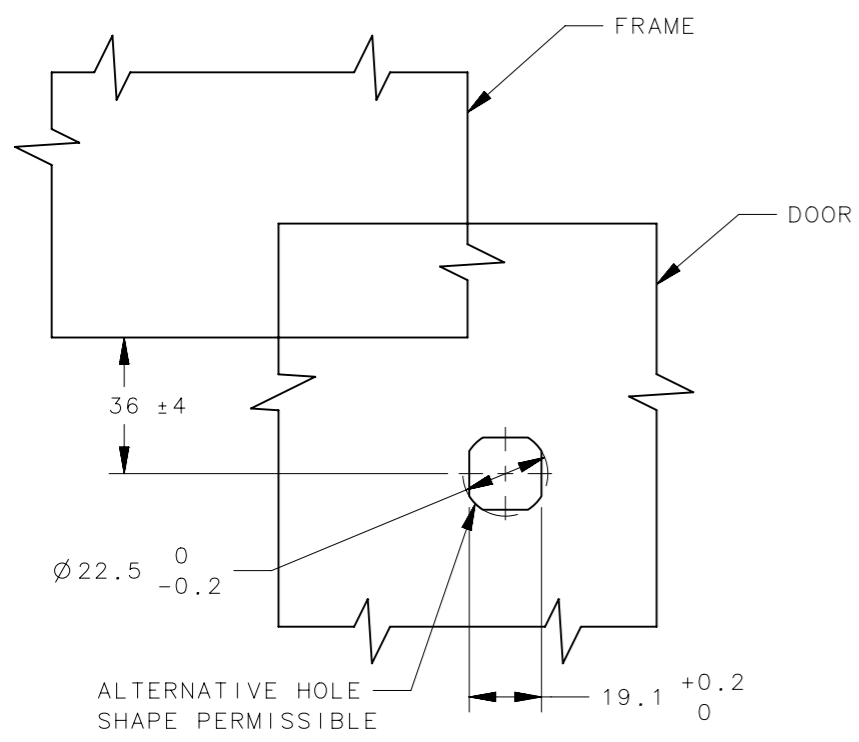

DOOR PREPARATION

- NOTES:
- OPERATION: 195° TURN OF DRIVER CAUSES CAM TO ROTATE AND PULL UP AS SHOWN.
 - DETERMINE TOTAL GRIP BY ADDING: MAX. OUTER DOOR THICKNESS(INCLUDE ALL ACCESSORIES) PLUS COMPRESSED FRAME GASKET AND FRAME THICKNESS.
 - FIND YOUR TOTAL GRIP IN CAM TABLE AND DETERMINE IF AN ASSEMBLED OR UNASSEMBLED LATCH IS TO BE USED BASED ON OUTER DOOR THICKNESS.
 - INSTALLATION:
 - INSERT LATCH INTO HOLE IN DOOR, IN THE UNLATCHED POSITION. CHECK FOR PROPER ORIENTATION AND OPERATION OF CAM.
 - RECOMMENDED MOUNTING NUT(27mm ACROSS FLATS) TIGHTENING TORQUE IS 20Nm AND CAM MOUNTING SCREW IS 10Nm.
 - ALL DRIVERS EXCEPT TUBULAR KEY STYLE MADE FROM 303/316 STAINLESS STEEL. TUBULAR KEY MADE FROM 303/316 STAINLESS STEEL.

16	-	1	SEAL	BUNA - N	NATURAL
15	-	1	GASKET SEAL	NEOPRENE	NATURAL
14	-	1	MOUNTING NUT	STAINLESS STEEL	NATURAL
13	-	1	LOCKWASHER	304 STAINLESS STEEL	PASSIVATED
12	-	1	SCREW	316 STAINLESS STEEL	PASSIVATED
11	-	1	CAM	304 STAINLESS STEEL	PASSIVATED
10	-	1	PIN	1008 STEEL	ZINC PLATE WITH YELLOW CHROMATE
9	-	1	SHAFT	316 STAINLESS STEEL	PASSIVATED
8	-	1	CAM	1075 STEEL	ZINC IMMERSION COATING
7	-	1	SLEEVE	304 STAINLESS STEEL	PASSIVATED
6	-	1	O-RING	BUNA-N	NATURAL
5	-	1	SPRING	302 STAINLESS STEEL	PASSIVATED
4	-	1	RETAINER	302 STAINLESS STEEL	NATURAL
3	-	1	BUSHING	316 STAINLESS STEEL	PASSIVATED
2	-	1	CAP	SEE NOTE 5	PASSIVATED
1	-	1	HOUSING	316 STAINLESS STEEL	PASSIVATED
-	E3-WWX-YYO		E3 LATCH SS	-	-
NO.	PART NUMBER	QTY.	TYPE OF COMPONENT	MATERIAL	FINISH

CPB NUMBER	THIRD ANGLE PROJECTION	
SURFACE AREA	MILLIMETERS [IN]	
VOLUME	TOLERANCES UNLESS OTHERWISE NOTED	DESCRIPTION E3 VISE ACTION LATCH, INTL SERIES, STAINLESS STEEL FIXED GRIP
PROPRIETARY ITEM	ALL DIMENSIONS WITHOUT TOLERANCES ARE FOR REFERENCE ONLY.	SIZE A3
EXCEPT FOR USES EXPRESSLY GRANTED IN WRITING, INFORMATION DISCLOSED HEREON IS CONFIDENTIAL AND ALL RIGHTS, PATENT AND OTHERWISE, ARE RESERVED BY SOUTHCO, INC.	PER ASME Y14.5M-2009	SYSTEM NX
		DWG NO. J-E3-10-2
		DRAWN BY LJC
		DATE 11MAY2001
		SCALE 1:1
		SHEET 1 OF 2

REVISION HISTORY			
REV	DATE	BY	DESCRIPTION
R	13JUN2024	BVM/CRM	PRN: P2024-1033

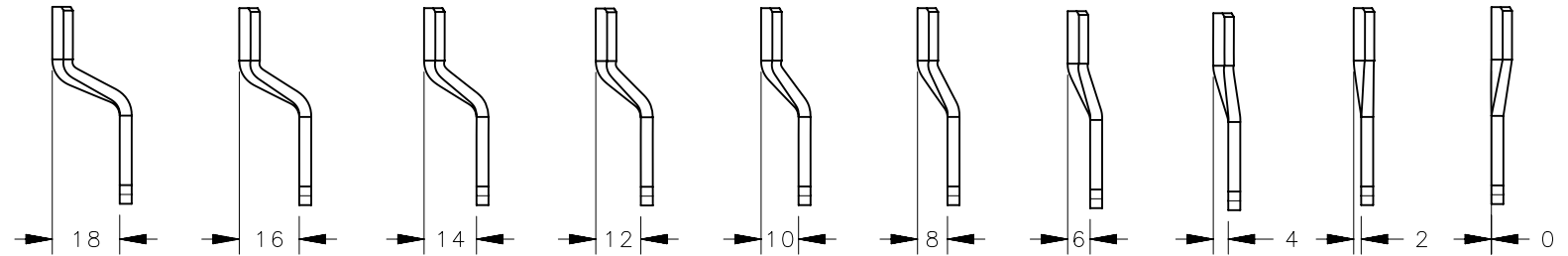

TOTAL GRIP	20	22	24	26	28	30	32	34	36	38
MAX. OUTER DOOR THICKNESS (LATCH ASSEMBLED)	1	2	4	5	6	7	7	7	7	7
GRIP (G)	00	01	02	03	04	05	06	07	08	09

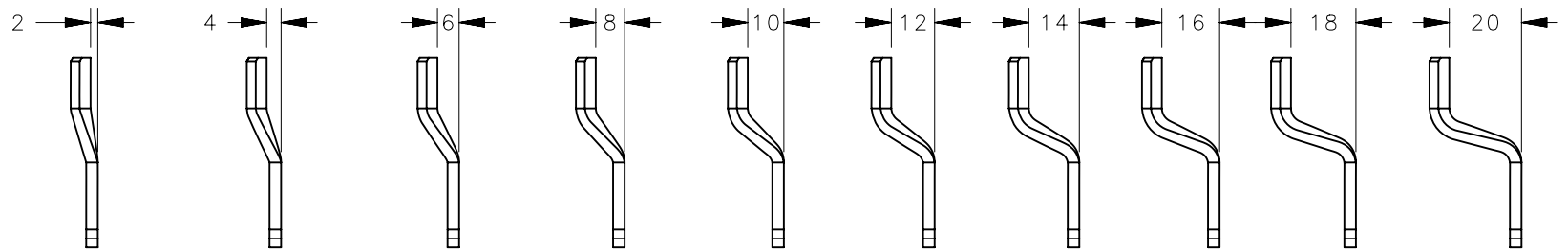

TOTAL GRIP	40	42	44	46	48	50	52	54	56	58
MAX. OUTER DOOR THICKNESS (LATCH ASSEMBLED)	7	7	7	7	7	7	7	7	7	7
GRIP (G)	10	11	12	13	14	15	16	17	18	19

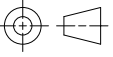
CPB NUMBER	THIRD ANGLE PROJECTION 	southco [®] CONNECT • CREATE • INNOVATE	
	MILLIMETERS [IN]		
SURFACE AREA	TOLERANCES UNLESS OTHERWISE NOTED	DESCRIPTION E3 VISE ACTION LATCH, INTL SERIES, STAINLESS STEEL FIXED GRIP	
VOLUME	ALL DIMENSIONS WITHOUT TOLERANCES ARE FOR REFERENCE ONLY.	SIZE A4	SYSTEM NX
PROPRIETARY ITEM EXCEPT FOR USES EXPRESSLY GRANTED IN WRITING, INFORMATION DISCLOSED HEREON IS CONFIDENTIAL AND ALL RIGHTS, PATENT AND OTHERWISE, ARE RESERVED BY SOUTHCO, INC.	PER ASME Y14.5M-2009	DWG NO. J-E3-10-2	
		DRAWN BY LJC	DATE 11MAY2001
		SCALE 1:2	SHEET 2 OF 2