

REVISION HISTORY			
REV	DATE	BY	DESCRIPTION
F	18OCT2016	DKM/YGC	PRN: P2016-2382

STANDARD PART NUMBER

E3 - B1 B2 - C1 C2

ACTUATION
DRIVER STYLE
GRIP
COLOR & FINISH

B1 = ACTUATION STYLE

- 10 = LATCH SHIPPED ASSEMBLED, TYPE A (TURN CAP CLOCKWISE TO LATCH)
- 12 = LATCH SHIPPED UNASSEMBLED, TYPE A (TURN CAP CLOCKWISE TO LATCH)
- 27 = LATCH SHIPPED ASSEMBLED, TYPE B (TURN CAP COUNTER-CLOCKWISE TO LATCH)
- 29 = LATCH SHIPPED UNASSEMBLED, TYPE B (TURN CAP COUNTER-CLOCKWISE TO LATCH)

C2 = COLOR AND FINISH

- 59 = BLACK HARD ANODIZE
- 06 = CLEAR POWDER COAT
- 56 = BLACK POWDER COAT
- 76 = SILVER POWDER COAT

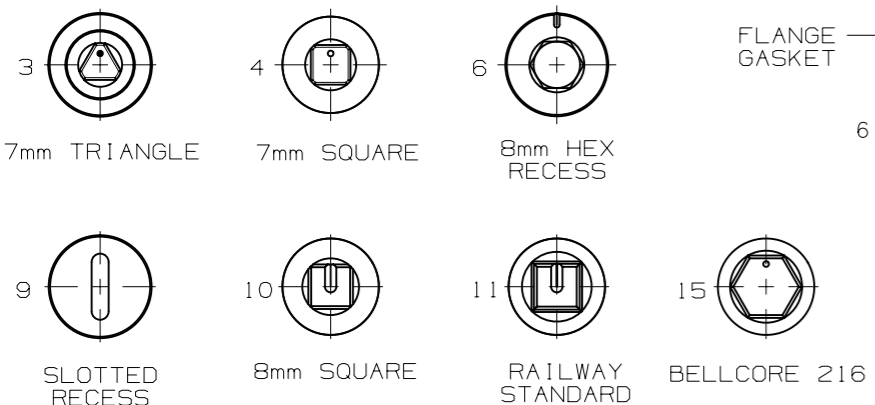
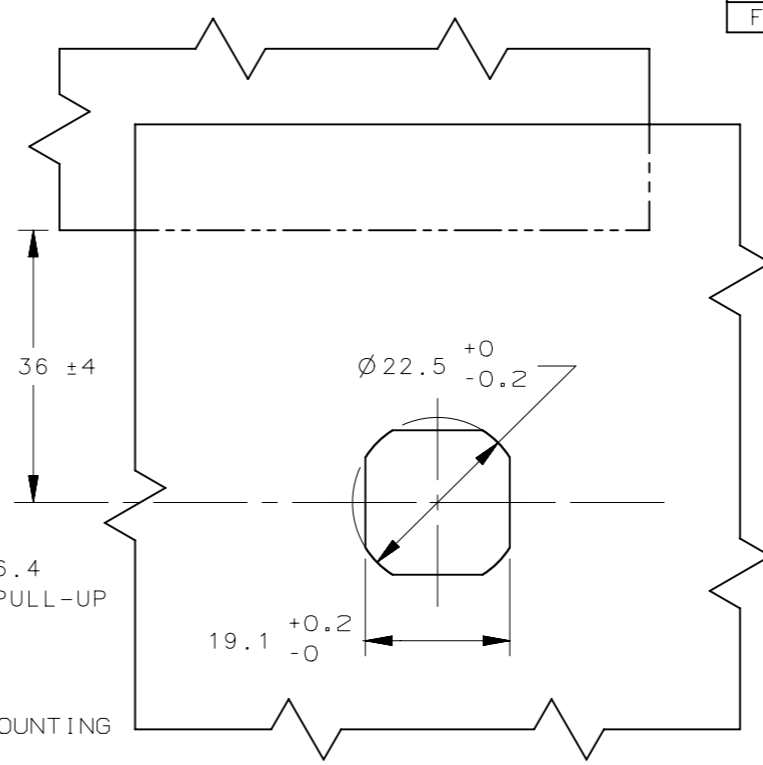
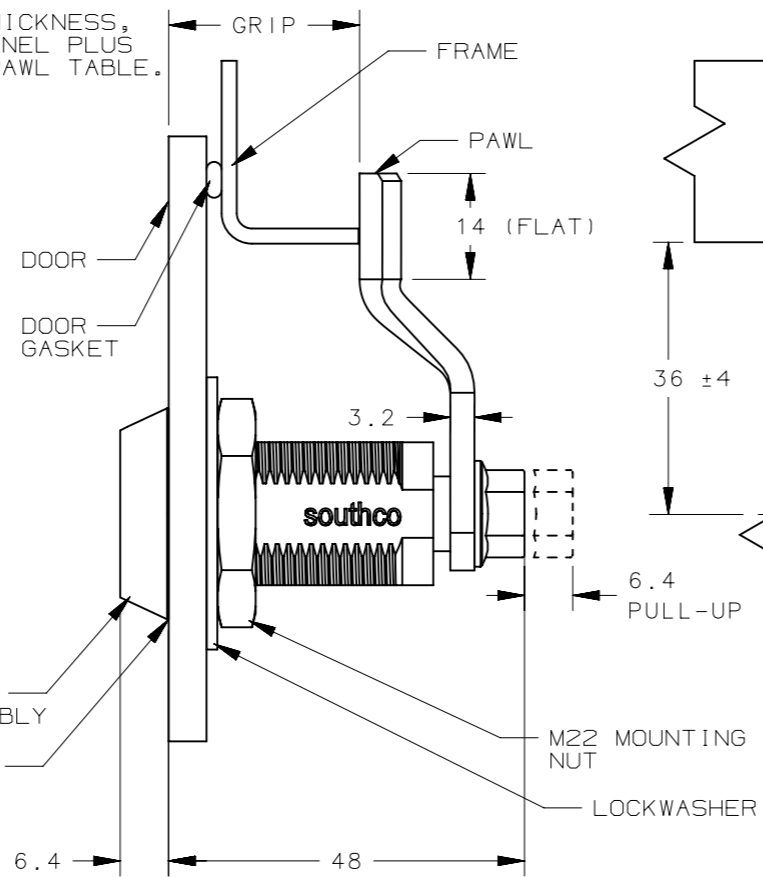
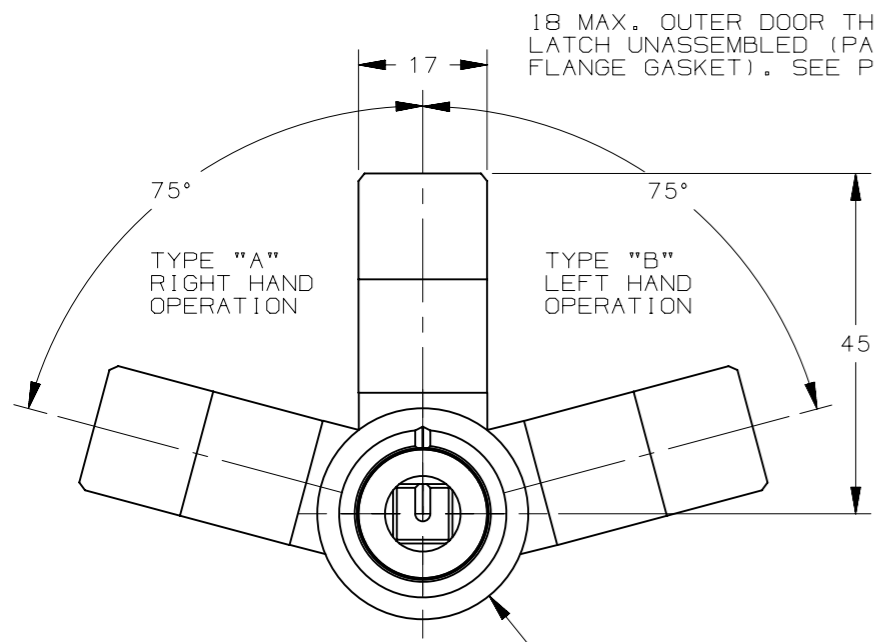

B2 = DRIVER STYLE	KEY PART NUMBER
7mm TRIANGLE	E3-3-1
7mm SQUARE	E3-4-1
8mm HEX RECESS	NOT SUPPLIED BY SOUTHCO
SLOTTED RECESS	NOT SUPPLIED BY SOUTHCO
8mm SQUARE	E3-8-1
RAILWAY STANDARD	E3-14-1
BELLCORE 216	E3-12-1

COMPONENT	MATERIAL	FINISH
HOUSING	ALUMINUM	ANODIZED OR PC
CAP	ALUMINUM	ANODIZED OR PC
BUSHING	ALUMINUM	ANODIZED OR PC
RETAINER	STAINLESS STEEL	NATURAL
SPRING	STAINLESS STEEL	NATURAL
O-RING	BUNA-N	NA
SLEEVE	STAINLESS STEEL	PASSIVATED
CAM	ALLOY STEEL	ZINC IMMERSION COATING
SHAFT	STAINLESS STEEL	PASSIVATED
PIN	STEEL	ZINC PLATE
PAWL (ANODIZED VERSION)	STAINLESS STEEL	PASSIVATED
PAWL (PC VERSION)	STEEL	ZINC PLATE
SCREW (ANODIZED VERISON)	STAINLESS STEEL	PASSIVATED
SCREW (PC VERISON)	STEEL	ZINC PLATE
LOCKWASHER (ANODIZED VERSION)	STAINLESS STEEL	PASSIVATED
LOCKWASHER (PC VERSION)	SPRING STEEL	ZINC PLATE
MOUNTING NUT (ANODIZED VERSION)	INTEC 1900	NATURAL
MOUNTING NUT (PC VERSION)	ZAMAK 3	CHROMATE
GASKET SEAL	NEOPRENE	NA
SEAL	NITRILE RUBBER	NA

- NOTES**
- OPERATION: 195° TURN OF DRIVER CAUSES PAWL TO ROTATE AND PULL UP AS SHOWN.
 - DETERMINE TOTAL GRIP BY ADDING: MAX. OUTER DOOR THICKNESS (INCLUDE ALL ACCESSORIES) PLUS COMPRESSED FRAME GASKET AND FRAME THICKNESS.
 - FIND YOUR TOTAL GRIP IN PAWL TABLE AND DETERMINE IF AN ASSEMBLED OR UNASSEMBLED LATCH IS TO BE USED BASED ON OUTER DOOR THICKNESS.
 - INSTALLATION:
 - INSERT LATCH INTO HOLE IN DOOR, IN THE UNLATCHED POSITION. CHECK FOR PROPER ORIENTATION AND OPERATION OF PAWL.
 - RECOMMENDED MOUNTING NUT (27mm ACROSS FLATS) TIGHTENING TORQUE IS 20Nm AND PAWL MOUNTING SCREW IS 10Nm.

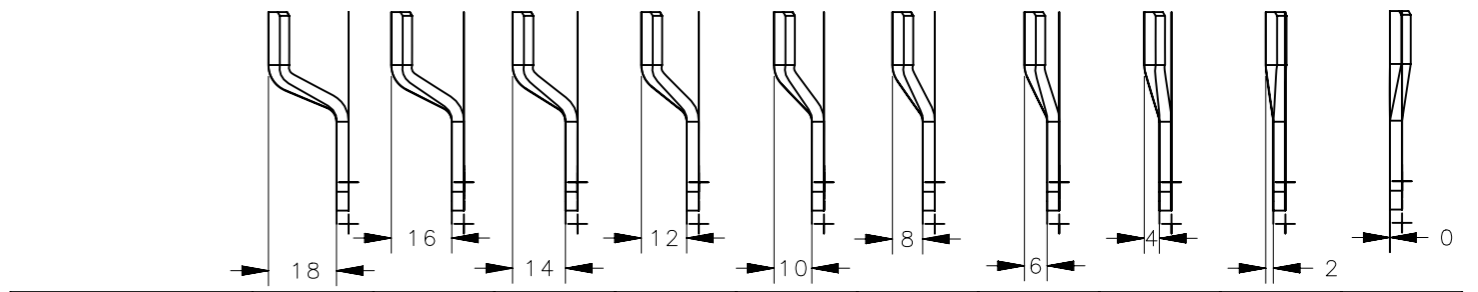

TOTAL GRIP	20	22	24	26	28	30	32	34	36	38
MAX. OUTER DOOR THICKNESS	1	2	4	5	6	7	7	7	7	7
GRIP STYLE (C1)	00	01	02	03	04	05	06	07	08	09

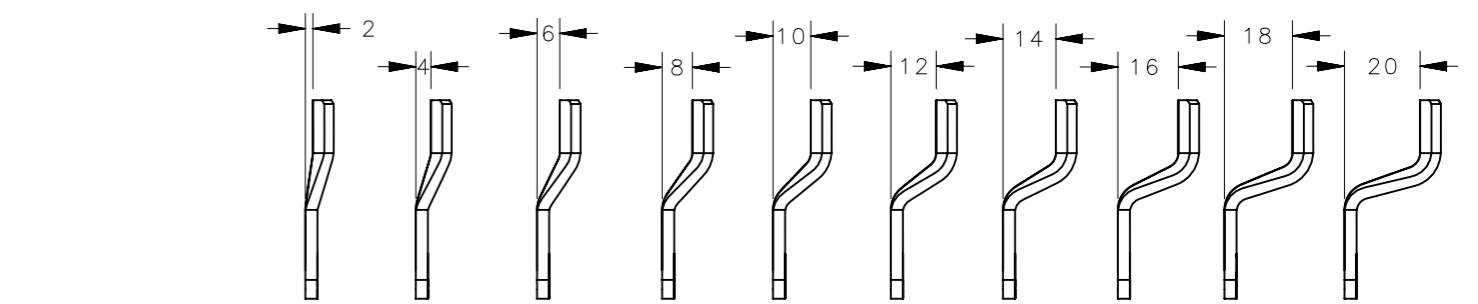

TOTAL GRIP	40	42	44	46	48	50	52	54	56	58
MAX. OUTER DOOR THICKNESS	7	7	7	7	7	7	7	7	7	7
GRIP STYLE (C1)	10	11	12	13	14	15	16	17	18	19

THIRD ANGLE PROJECTION

MILLIMETERS [IN]

TOLERANCES UNLESS OTHERWISE NOTED
ALL DIMENSIONS WITHOUT TOLERANCES ARE FOR REFERENCE ONLY.

PROPRIETARY ITEM
EXCEPT FOR USES EXPRESSLY GRANTED IN WRITING, INFORMATION DISCLOSED HEREON IS CONFIDENTIAL AND ALL RIGHTS, PATENT AND OTHERWISE, ARE RESERVED BY SOUTHCO, INC.

PER ASME Y14.5M-1994

southco
CONNECT • CREATE • INNOVATE

DESCRIPTION: Compression Latch ALUMINUM E3, MIN PROTRUSION

SIZE: A3 SYSTEM: NX DWG NO.: J-E3-12-12

DRAWN BY: ZCF DATE: 01FEB2013 SCALE: NTS SHEET: 1 OF 1