

REVISION HISTORY			
REV	DATE	BY	DESCRIPTION
G	15NOV2021	SSW/MBT	PRN: P2021-2226

ASSEMBLY PART NUMBER

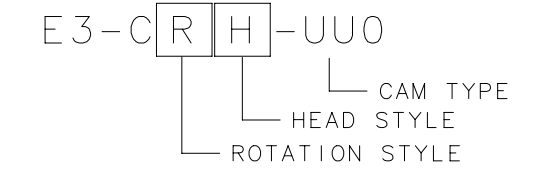

R=ROTATION STYLE:  
 12= TYPE A TURN CLOCKWISE TO LATCH  
 29= TYPE B TURN COUNTERCLOCKWISE TO LATCH

TOTAL GRIP	CAM NUMBER	TOTAL GRIP	CAM NUMBER
4	E3-28-700-24	24	E3-28-710-24
6	E3-28-701-24	26	E3-28-711-24
8	E3-28-702-24	28	E3-28-712-24
10	E3-28-703-24	30	E3-28-713-24
12	E3-28-704-24	32	E3-28-714-24
14	E3-28-705-24	34	E3-28-715-24
16	E3-28-706-24	36	E3-28-716-24
18	E3-28-707-24	38	E3-28-717-24
20	E3-28-708-24	40	E3-28-718-24
22	E3-28-709-24	42	E3-28-719-24

HEAD STYLE	KEY PART NUMBER
7mm TRIANGLE	E3-3-1
7mm SQUARE	E3-4-1
8mm TRIANGLE	E3-7-1
8mm SQUARE	E3-8-1
BELLCORE 216	E3-12-1
RAILWAY	E3-14-1

MATERIAL AND FINISH:

GASKET	PORON	NATURAL
SCREW	316 STAINLESS STEEL	PASSIVATED
FLANGE GASKET	NEOPRENE	NATURAL
LOCK WASHER	304 STAINLESS STEEL	NATURAL
MOUNTING NUT	STAINLESS STEEL	NATURAL
PIN	1008 STEEL	ZINC PLATE PLUS YELLOW CHROMATE
O-RING	BUNA-N	NATURAL
RETAINER	302 SS	NATURAL
SPRING	MUSIC WIRE	ZINC PLATE PLUS BRIGHT CHROMATE
SHAFT	304 STAINLESS STEEL	PASSIVATED
SLEEVE	1075 STEEL	ZINC IMMERSION COATING
CAM	1075 STEEL	ZINC IMMERSION COATING
CAP	304 STAINLESS STEEL	PASSIVATED
HOUSING	304 STAINLESS STEEL	PASSIVATED

NO.	E3-CRH-UU0 PART NUMBER	QTY	ASSEMBLY TYPE OF COMPONENT	GENERAL NOTES

THIRD ANGLE PROJECTION				
TOLERANCES UNLESS OTHERWISE NOTED		DESCRIPTION		
ALL DIMENSIONS WITHOUT TOLERANCES ARE FOR REFERENCE ONLY.		STAINLESS STEEL SHORT E3 LATCH VISE ACTION SERIES		
PROPRIETARY ITEM	PER ASME Y14.5M-1994	SIZE A3	SYSTEM NX	DWG NO. J-E3-C-12-2
EXCEPT FOR USES EXPRESSLY GRANTED IN WRITING, INFORMATION DISCLOSED HEREON IS CONFIDENTIAL AND ALL RIGHTS, PATENT AND OTHERWISE, ARE RESERVED BY SOUTHCO, INC.		DRAWN BY CL/BX	DATE 30JUL2015	SCALE 1:1 SHEET 1 OF 1

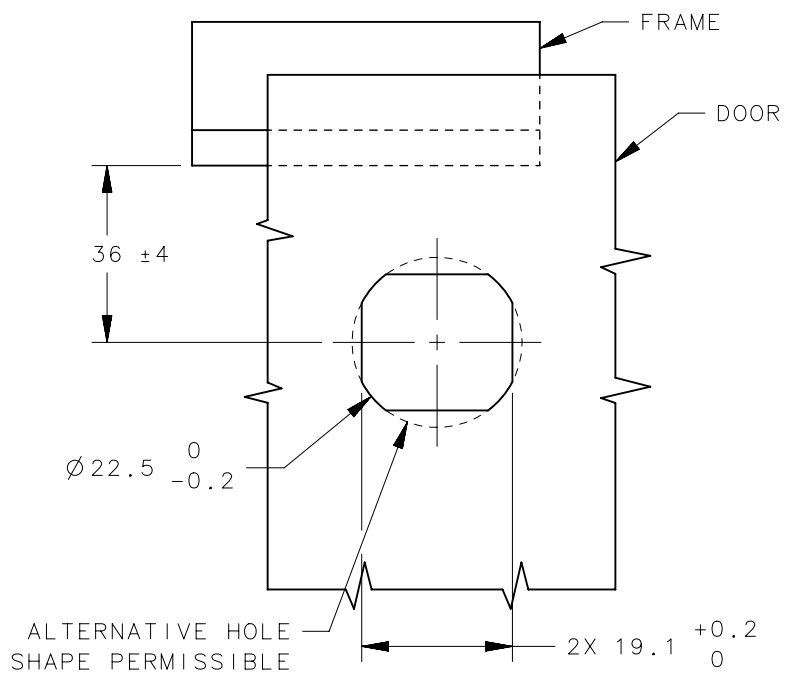
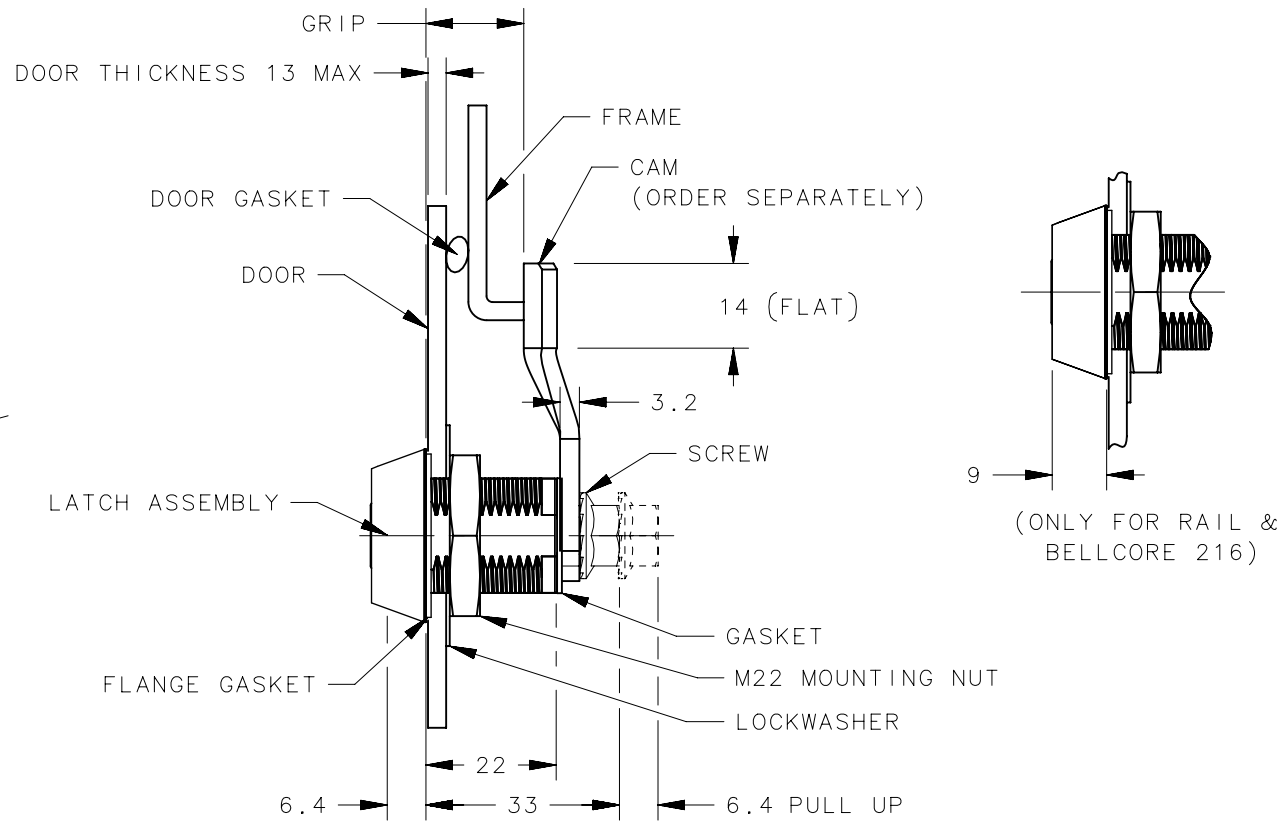
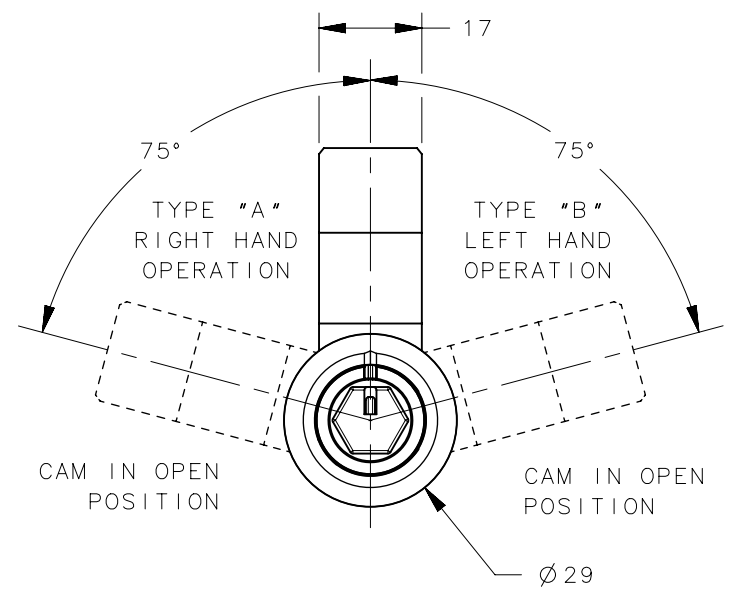

DOOR PREPARATION

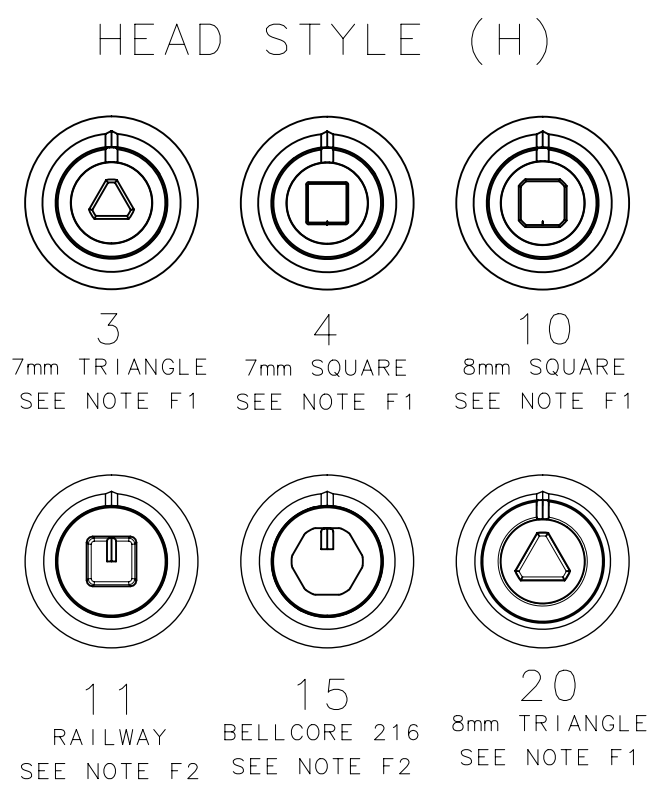

- NOTES:
- OPERATION: 195° TURN OF DRIVER CAUSES CAM TO ROTATE THEN PULL UP AS SHOWN.
  - DETERMINE TOTAL GRIP BY ADDING MAX OUTER DOOR THICKNESS(INCLUDE ALL ACCESSORIES) PLUS COMPRESSED GASKETS AND FRAME THICKNESS.
  - INSTALLATION:
    - INSERT LATCH INTO THE HOLE OF THE DOOR IN THE UNLATCHED POSITION. CHECK FOR PROPER ORIENTATION AND OPERATION OF CAM.
    - INSTALL LOCKWASHER AND MOUNTING NUT ONTO HOUSING. RECOMMENDED TIGHTENING TORQUE FOR MOUNTING IS 20 Nm.
    - INSTALL CAM AND CAM MOUNTING SCREW. RECOMMENDED TORQUE IS 10 Nm.
  - CHOOSE CAM ACCORDING TO THE TOTAL GRIP FROM THE CAM TABLE.
  - FOR ALTERNATIVE LATCH PACKAGING WITH CAM, SEE DRAWING J-E3-C-12-2A.
  - LATCH HEADSTYLE FITTING WITH KEY:
    - KEY OD Ø13.3 MAX
    - KEY OD Ø18 MAX