

REVISION HISTORY			
REV	DATE	BY	DESCRIPTION
B	19JAN2021	ABK/VK	PRN: P2021-0123

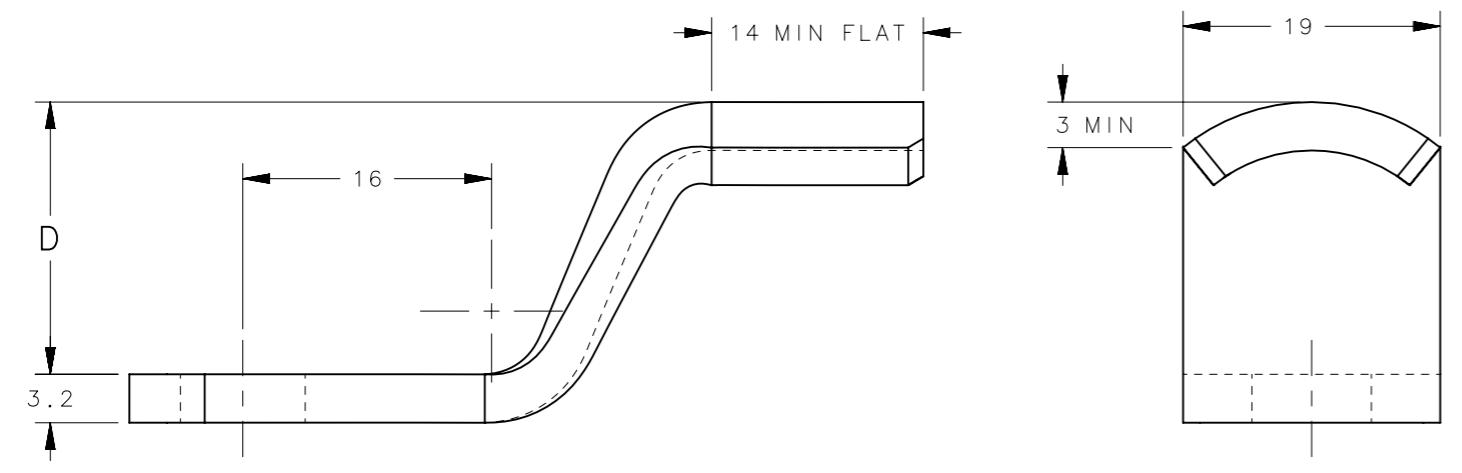

PART No. E5-2500
SHOWN HERE

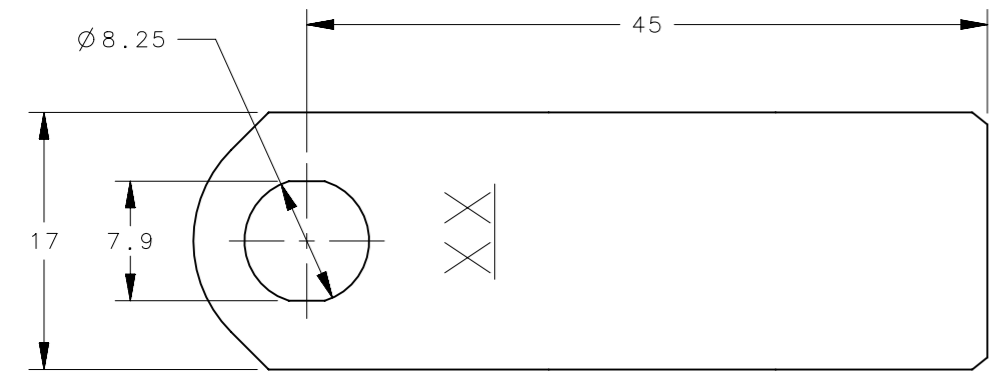
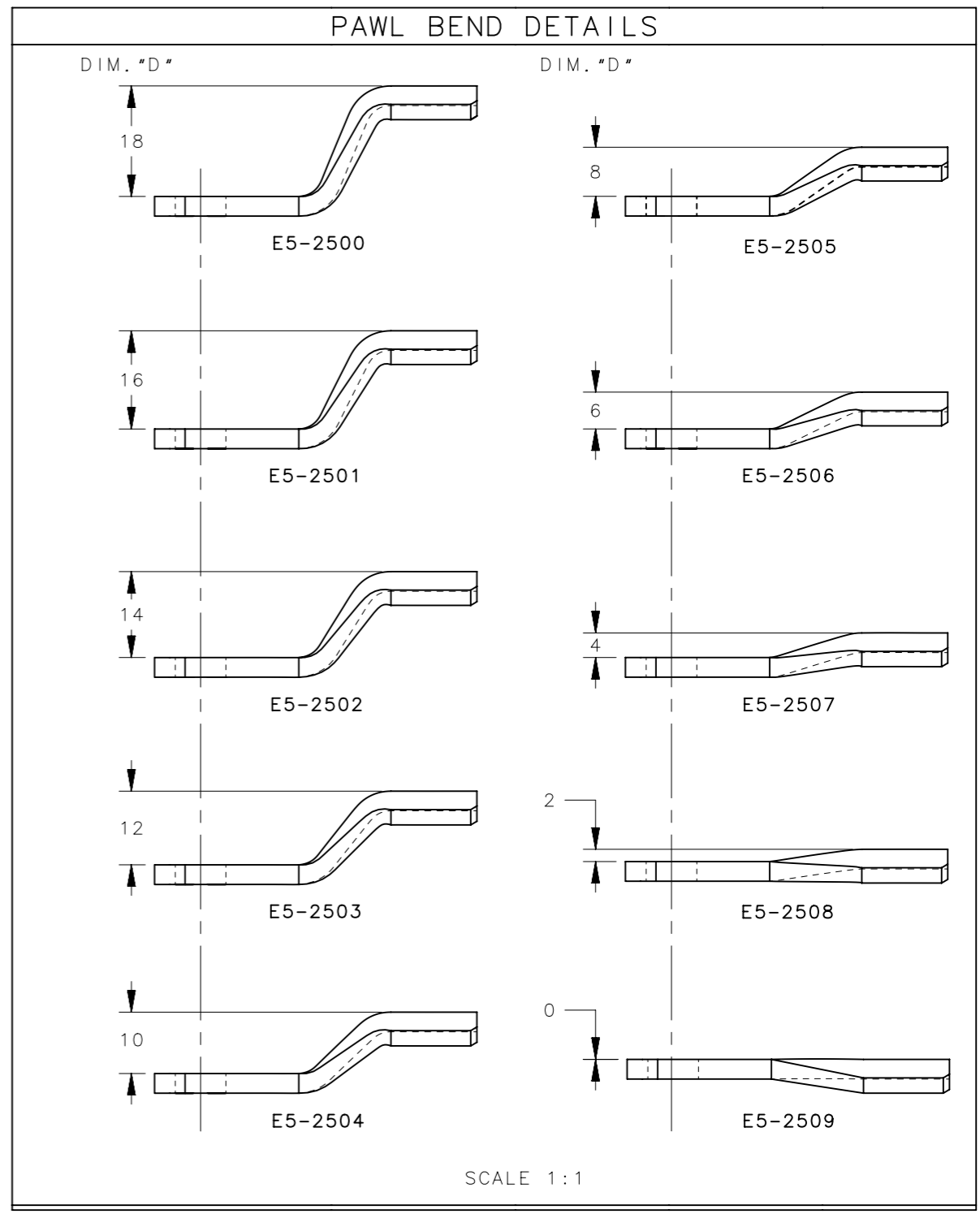

NOTES:

- ALL DIMENSIONS SHOWN IN THIS SECTION OF THE DRAWING ARE TYPICAL OF ALL PAWLS.

E5-25XX-20	PAWL	STAINLESS STEEL	NATURAL
E5-25XX-24	PAWL	STAINLESS STEEL	PASSIVATED
E5-25XX-30	PAWL	STEEL	NATURAL
E5-25XX	PAWL	STEEL	ZINC PLATE CHROMATE DIP
PART NUMBER	TYPE OF COMPONENT	MATERIAL	FINISH

THIRD ANGLE PROJECTION		southco [®] CONNECT • CREATE • INNOVATE	
MILLIMETERS [IN]			
TOLERANCES UNLESS OTHERWISE NOTED		DESCRIPTION E5 PAWL - BENT UP POSITION	
SURFACE AREA 2447.10mm ²	ALL DIMENSIONS WITHOUT TOLERANCES ARE FOR REFERENCE ONLY.	SIZE A3	SYSTEM NX
VOLUME 3021.97 mm ³		DWG NO. J-E5-25-1	
PROPRIETARY ITEM <small>EXCEPT FOR USES EXPRESSLY GRANTED IN WRITING, INFORMATION DISCLOSED HEREON IS CONFIDENTIAL AND ALL RIGHTS, PATENT AND OTHERWISE, ARE RESERVED BY SOUTHCO, INC.</small>		PER ASME Y14.5M-1994	DRAWN BY MJS
		SCALE 2:1	SHEET 1 OF 1