

REVISION HISTORY			
REV	DATE	BY	DESCRIPTION
G	30JUL2019	CMS/KH	PRN: P2019-1847

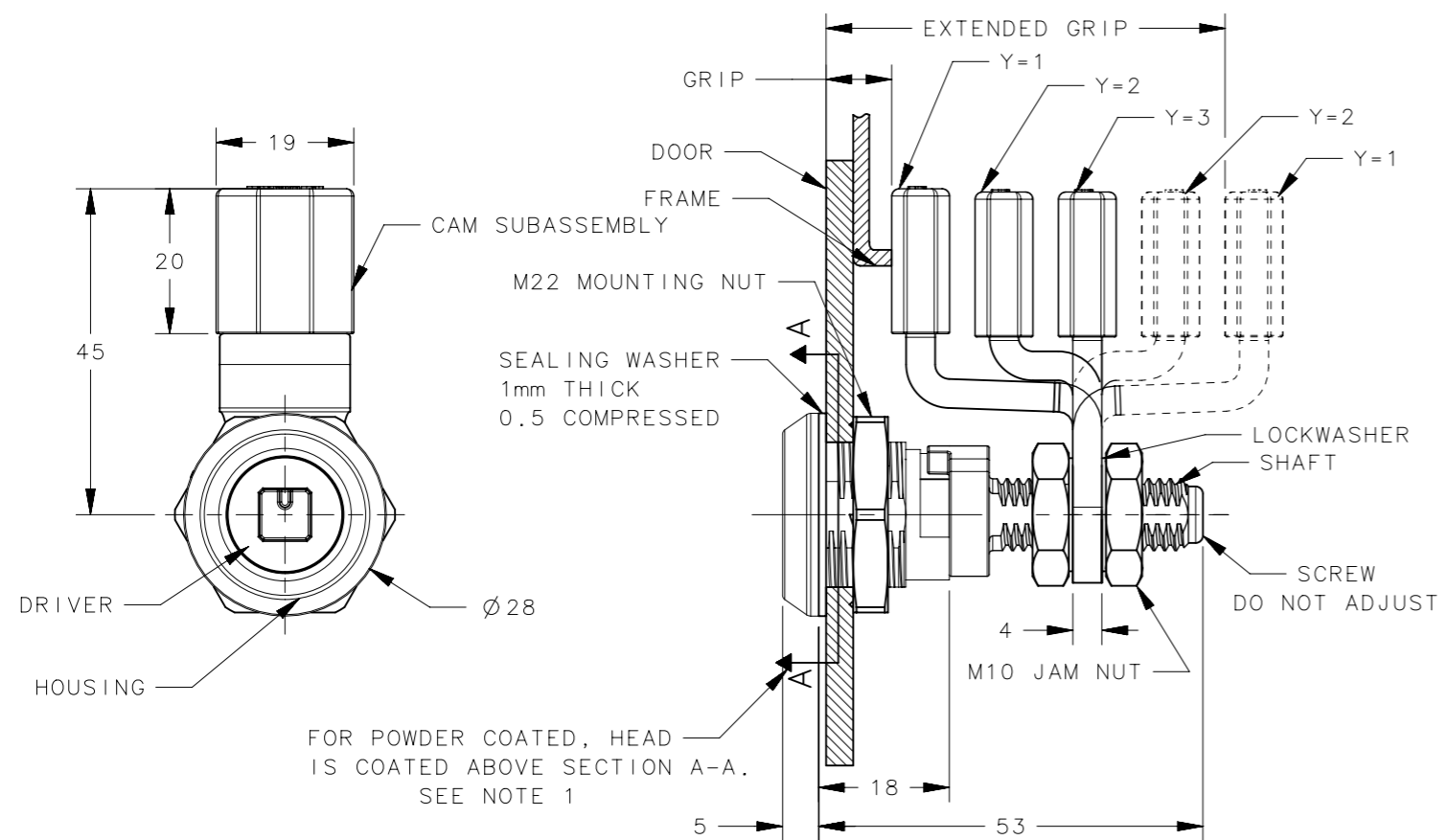

FOR POWDER COATED, HEAD IS COATED ABOVE SECTION A-A. SEE NOTE 1

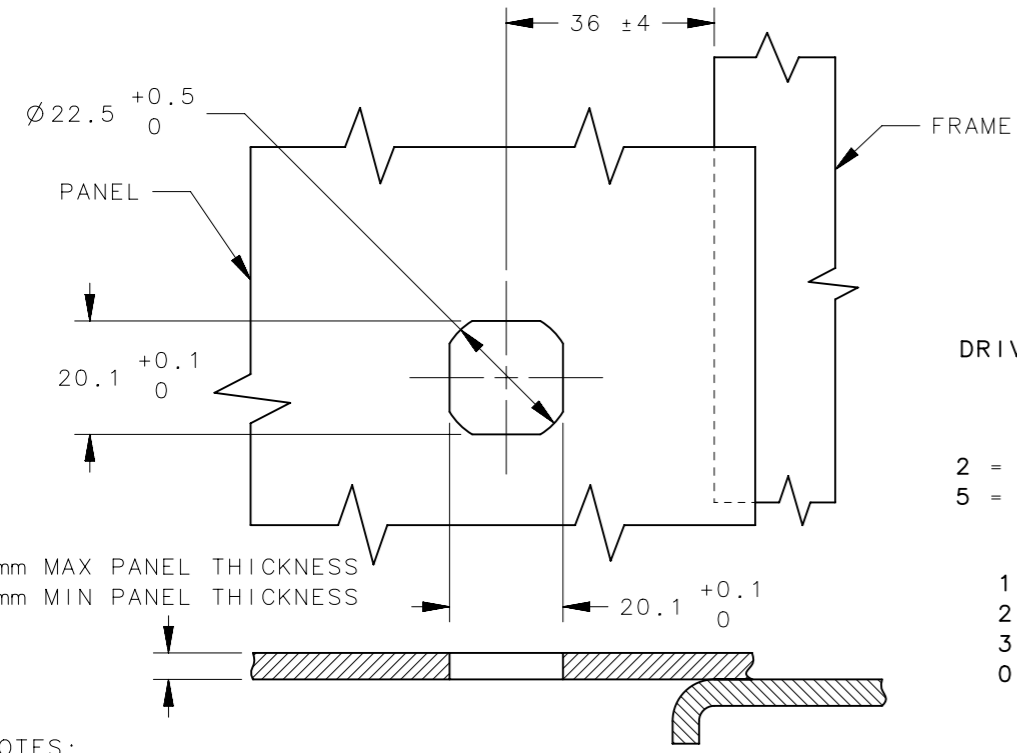

E5-6-WWX-Y1

DRIVER ACTUATION STYLE

FINISH

2 = BRIGHT CHROME PLATE
5 = BLACK POWDER COAT

CAM TYPE

1 = DEEP OFFSET CAM
2 = OFFSET CAM
3 = STRAIGHT CAM
0 = NO CAM (CAM ORDER SEPARATELY)

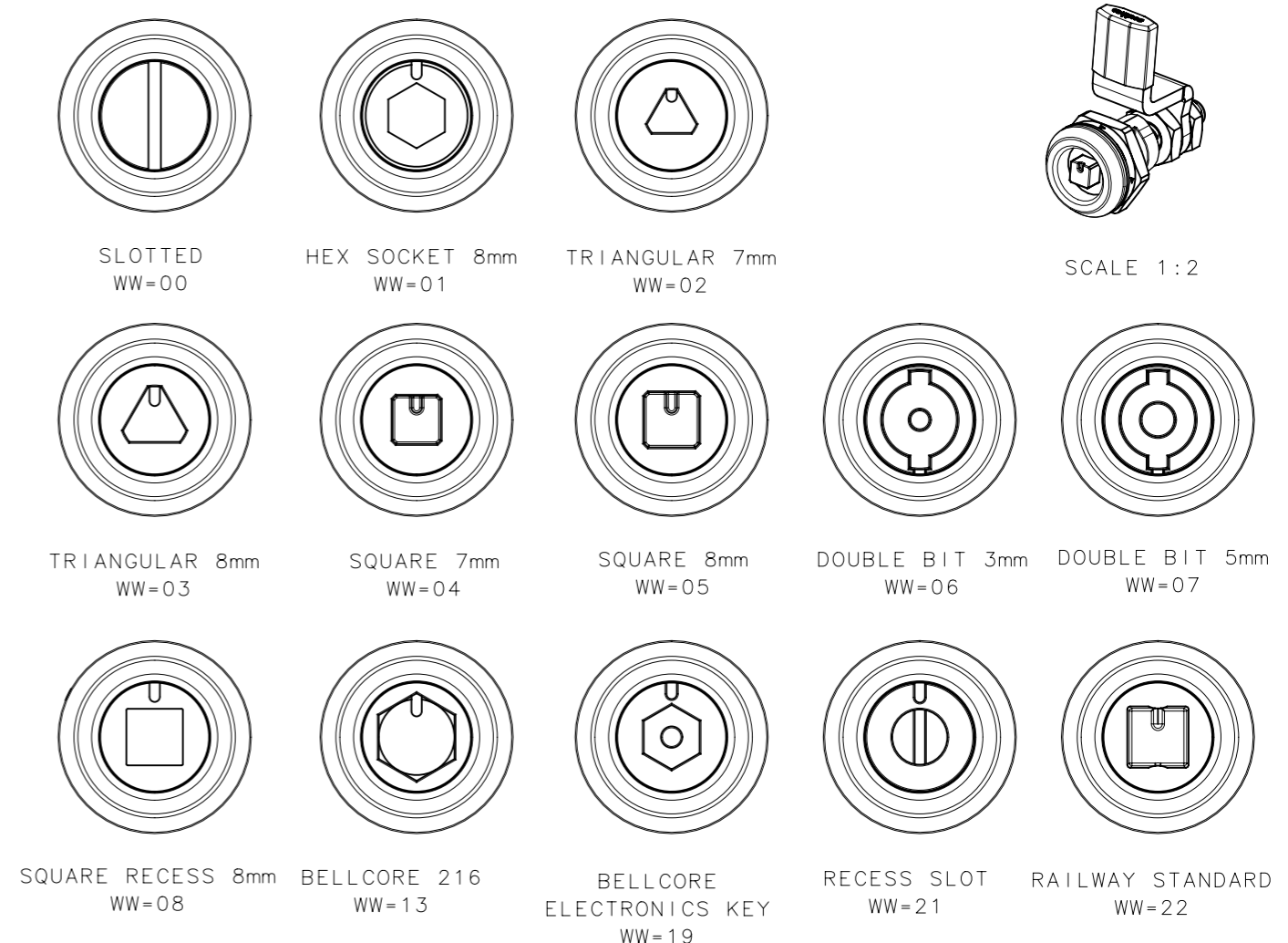

Y	DESCRIPTION	GRIP RANGE (FORWARD)	GRIP RANGE (REVERSE)	CAM PART NUMBER
1	DEEP OFFSET, CAM	5mm-16.5mm	51mm-62.5mm	E5-4001
2	OFFSET, CAM	16.5mm-28mm	39.5mm-51mm	E5-4002
3	STRAIGHT, CAM	28mm-39.5mm		E5-4003

11	-	2	LOCKWASHER	SPRING STEEL	ZINC PLATE PLUS YELLOW CHROMATE
10	-	2	M10 JAM NUT	STEEL	ZINC PLATE PLUS BRIGHT CHROMATE
9	-	1	SCREW	STEEL	ZINC PLATE PLUS BRIGHT CHROMATE
8	-	1	SHAFT	DIE CAST ZINC	NATURAL
7	-	1	SPRING	MUSIC WIRE	ZINC PLATE PLUS BRIGHT CHROMATE
6	-	1	HOUSING	DIE CAST ZINC	SEE TABLE
5	-	1	CAM SUBASSEMBLY	SEE NOTE 4	SEE NOTE 4
4	-	1	M22 MOUNTING NUT	DIE CAST ZINC	BRIGHT CHROMATE
3	-	1	O-RING	BUNA N	NATURAL
2	-	1	SEALING WASHER	LDPE (LOW DENSITY POLYETHYLENE)	BLACK
1	-	1	DRIVER	DIE CAST ZINC	SEE TABLE
-	E5-6-WWX-Y1	-	ASSEMBLY	-	-
NO.	PART NUMBER	QTY	TYPE OF COMPONENT	MATERIAL	FINISH

- NOTES:
- COSMETIC SPECIFICATION: SURFACES ABOVE A-A ARE TO CONFORM TO CLASS "B" DESIGNATION AS DESCRIBED IN SOUTHCO COSMETIC SPECIFICATIONS: S-121-01 FOR X = 2 AND S-121-03 FOR X = 5
 - INSTALLATION:
 - INSERT LATCH INTO HOLE IN DOOR. CHECK FOR PROPER ORIENTATION AND OPERATION USING PAWL.
 - INSTALL MOUNTING NUT (M22 ACROSS FLATS). TIGHTENING TORQUE IS 10Nm MAX.
 - INSTALL JAM NUT, LOCKWASHER, PAWL, LOCKWASHER AND JAM NUT ON SHAFT. ADJUST JAM NUTS TO POSITION PAWL AT CORRECT GRIP (WITH LATCH CLOSED). TIGHTENING TORQUE IS 7Nm MAX, USING TWO 17mm WRENCHES.
 - CAM AND HARDWARE SHIPPED UNASSEMBLED FROM LATCH.
 - MATERIAL AND FINISH OF CAM SUBASSEMBLY: CAM: STEEL, ZINC PLATE PLUS BRIGHT CHROMATE COVER: NYLON, BLACK.

THIRD ANGLE PROJECTION			
MILLIMETERS [IN]			
SURFACE AREA		TOLERANCES UNLESS OTHERWISE NOTED	
VOLUME		ALL DIMENSIONS WITHOUT TOLERANCES ARE FOR REFERENCE ONLY.	
PROPRIETARY ITEM		DESCRIPTION: E5 METAL QUAD LATCH (TOOL SECURED) ADJUSTABLE GRIP	
EXCEPT FOR USES EXPRESSLY GRANTED IN WRITING, INFORMATION DISCLOSED HEREON IS CONFIDENTIAL AND ALL RIGHTS, PATENT AND OTHERWISE, ARE RESERVED BY SOUTHCO, INC.		SIZE: A3	SYSTEM: NX
PER ASME Y14.5M-1994		DWG NO.: J-E5-6-1	SCALE: 1:1
		DRAWN BY: VK	DATE: 14DEC2016
		SHEET 1 OF 1	