

REVISION HISTORY			
REV	DATE	BY	DESCRIPTION
E	07FEB2018	CJ/JQ	PRN: P2018-0295

HEAD STYLE (WW)

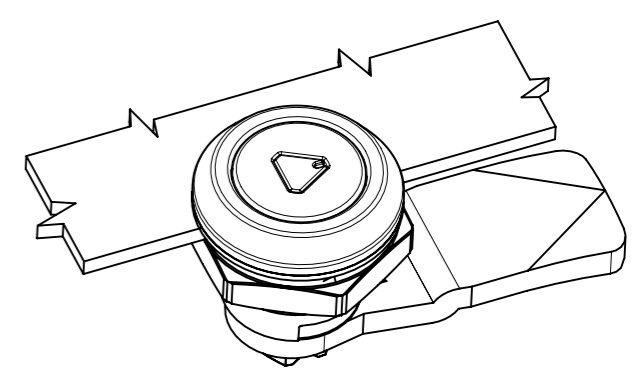
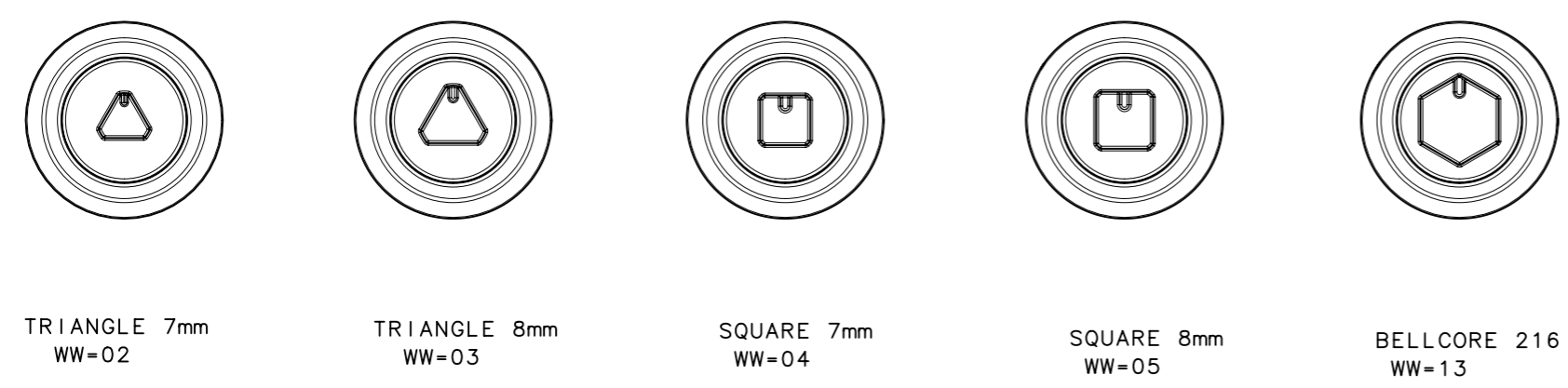

NOTES:

- MATERIAL AND FINISH:
 HOUSING/DRIVER/SLIDE BUSHING:
 DIE CASTING ZINC, CHROME PLATED OR BLACK PC;
 OR 300 SERIES STAINLESS STEEL, ELECTRONIC POLISH;
 STATIONARY BUSHING: DIE CASTING ZINC, PASSIVATED;
 OR 300 SERIES STAINLESS STEEL, ELECTRONIC POLISH;
 MOUNTING NUT: DIE CASTING ZINC, ZINC PLATED;
 OR 300 SERIES STAINLESS STEEL, PASSIVATED;
 MOUNTING SCREW: LOW CARBON STEEL, ZINC PLATED, 3M PATCH;
 OR 300 SERIES STAINLESS STEEL, PASSIVATED;
 SPRING: 300 SERIES STAINLESS STEEL, PASSIVATED
 STOP WASHER: 300 SERIES STAINLESS STEEL, PASSIVATED
 O-RING: NITRILE, BLACK
 SEALING WASHER: POLYURETHANE, BLACK
- COSMETIC SPECIFICATION: ALL SURFACES ABOVE A-A CONFIRM TO CLASS B PER SOUTHCO COSMETIC SPEC S-121. OTHERS WILL CONFIRM TO CLASS D.
- CAM LATCH E5-8-WW2/WW5-UU1 USE CAM E5-60YY AND E5-8-WW28-UU1 USE CAM E5-80YY. BOTH CAMS CAN BE ORDERED SEPERATELY.

INSTALLATION

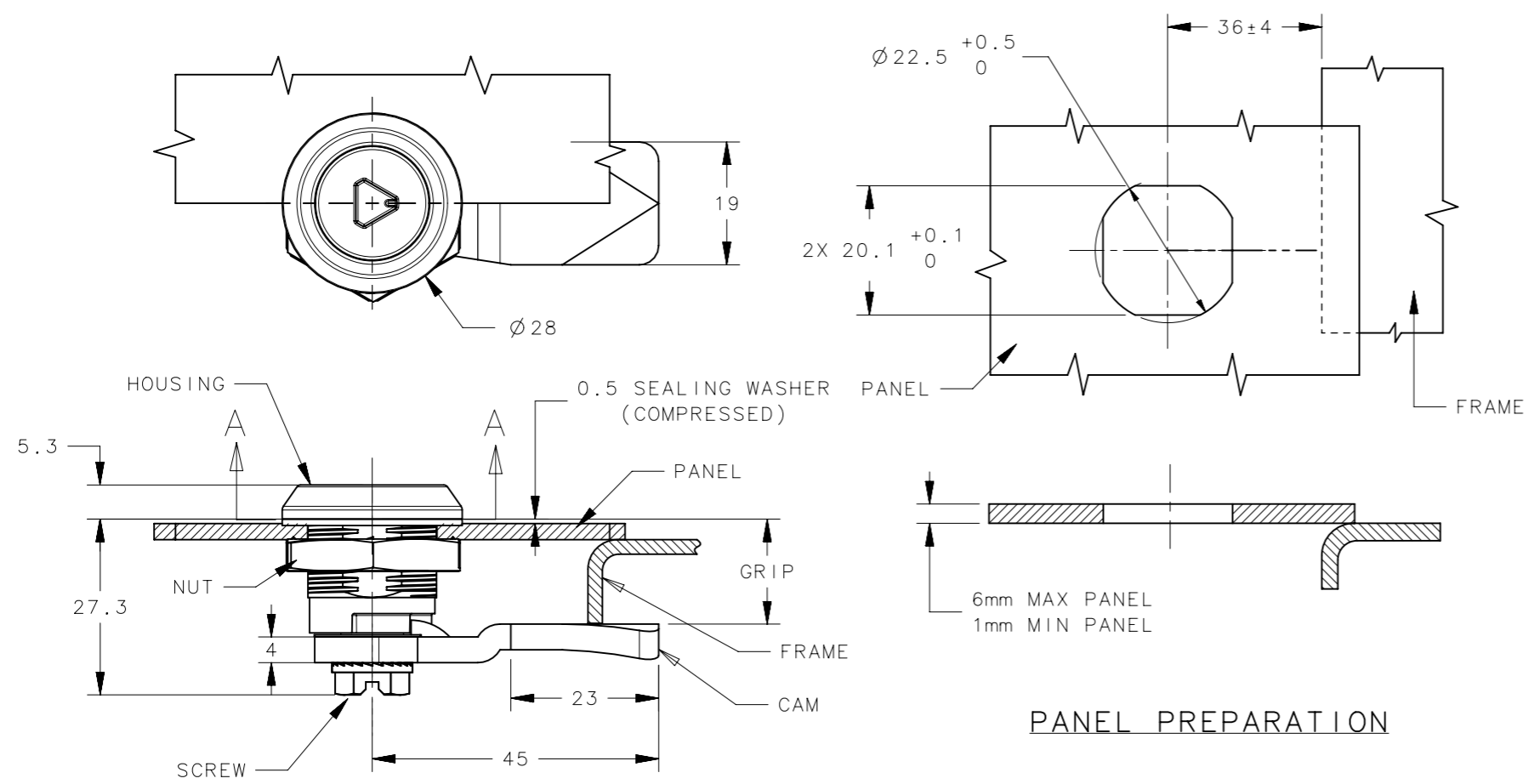

INSTALLATION METHOD

- PLACE SEALING WASHER ONTO LATCH HOUSING AND PLACE THROUGH MOUNTING HOLE.
- INSTALL MOUNTING NUT AND TIGHTEN TO 10 N.m MAX.
- ATTACH CAM TO LATCH ASSEMBLY. ASSURE THAT CAM INDICATION POINTS TO CAM LOCATION.
- INSTALL SCREW AND TIGHTEN TO 5 N.m MAX.

WW: SEE ABOVE HEAD STYLE
 X: -2 DIE CASTING ZINC, CHROME PLATED
 -5 DIE CASTING ZINC, BLACK POWDER COATED
 -28 300 SERIES STAINLESS STEEL, ELECTROPOLISHED

USE CAM E5-60YY/80YY (ORDER SEPARATELY)

GRIP (mm)	4	6	8	10	12	14	16	18	20	22	24	26	28	30	32	34	36	38	40	42
YY	03	04	05	06	07	08	09	10	11	12	13	14	15	16	17	18	19	20	21	22

E5-8-WWX-UU1	ASSEMBLY	SEE NOTES	SEE NOTES
PART NUMBER	TYPE OF COMPONENT	MATERIAL	FINISH
THIRD ANGLE PROJECTION			
MILLIMETERS [IN]			
SURFACE AREA mm ²		DESCRIPTION	
VOLUME mm ³		CAM LATCH	
PROPRIETARY ITEM		SIZE	SYSTEM
EXCEPT FOR USES EXPRESSLY GRANTED IN WRITING, INFORMATION DISCLOSED HEREON IS CONFIDENTIAL AND ALL RIGHTS, PATENT AND OTHERWISE, ARE RESERVED BY SOUTHCO, INC.		A3	NX
PER ASME Y14.5M-1994		DWG NO.	J-E5-8
DRAWN BY CJ/JQ		DATE	30JUL2015
SCALE		1:1	SHEET 1 OF 1