

REVISION HISTORY			
REV	DATE	BY	DESCRIPTION
A	23AUG2024	SBK/VK	IPN: 1P-2024-2045

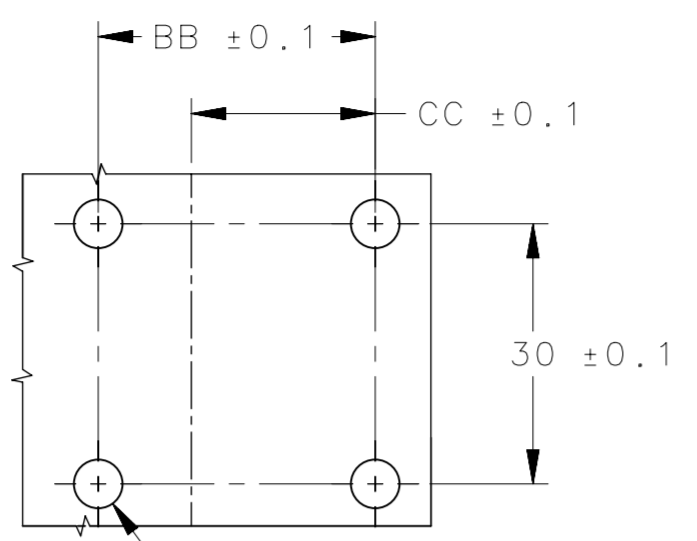

4X Ø 6.5 ± 0.1
PANEL PREPRATION

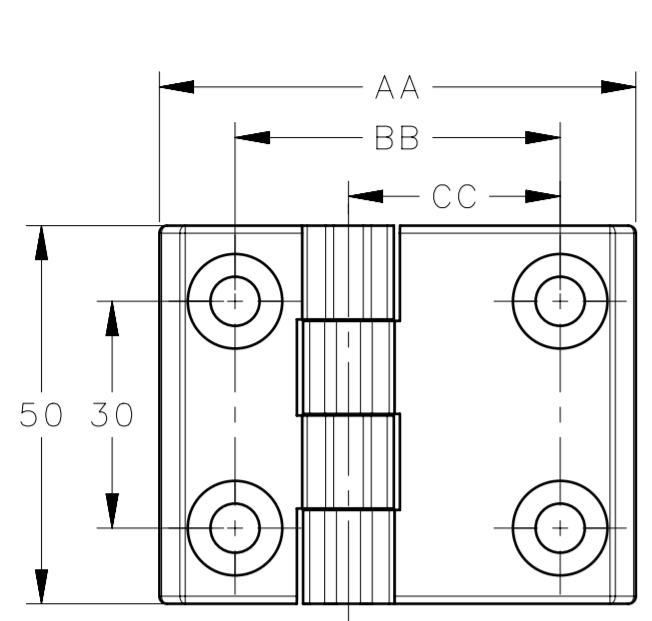
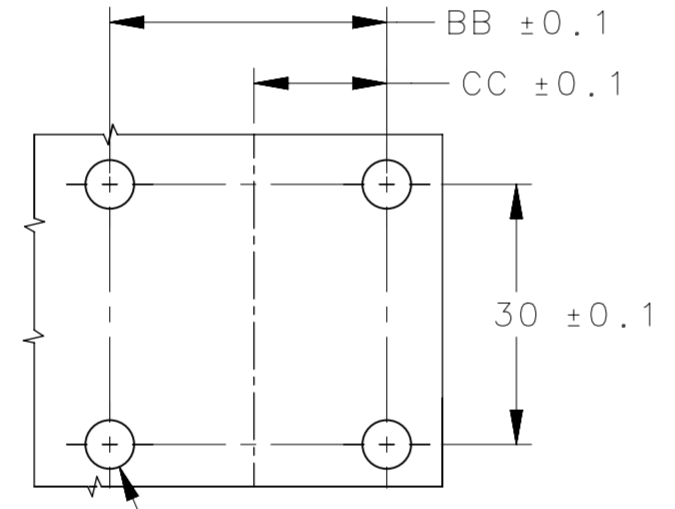
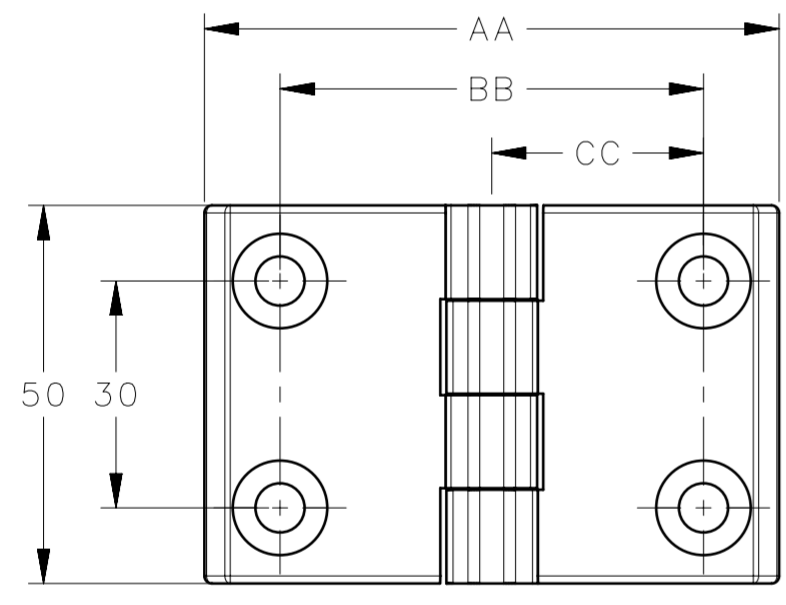
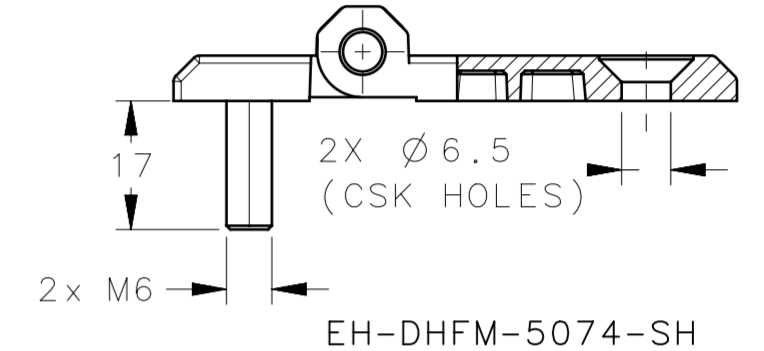
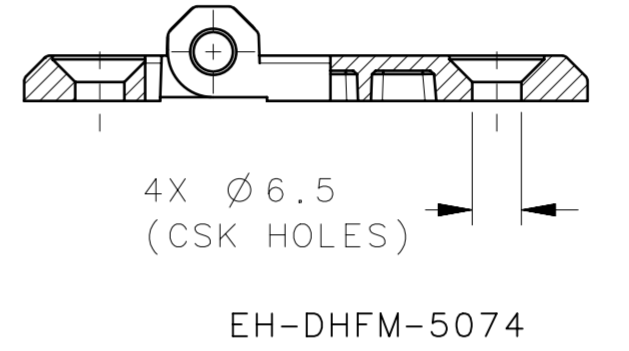
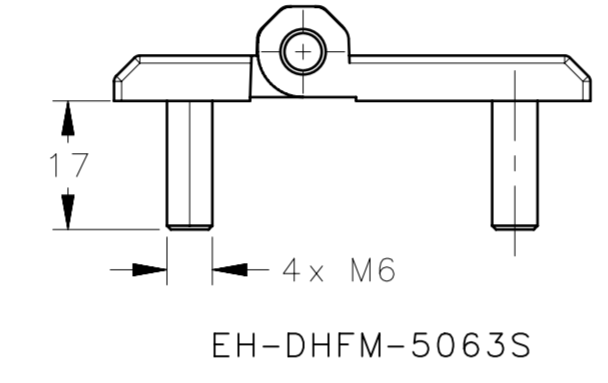
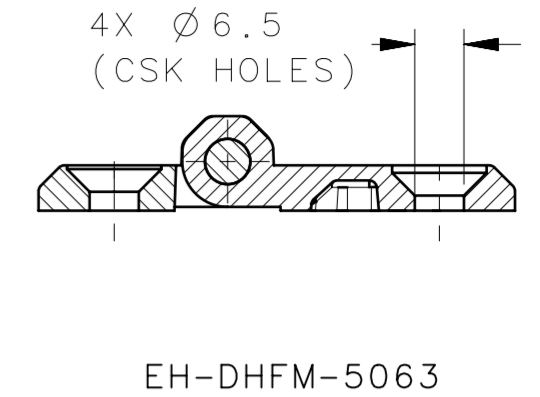
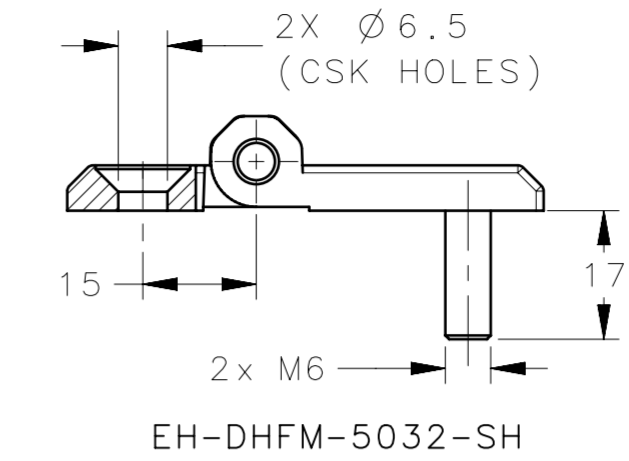
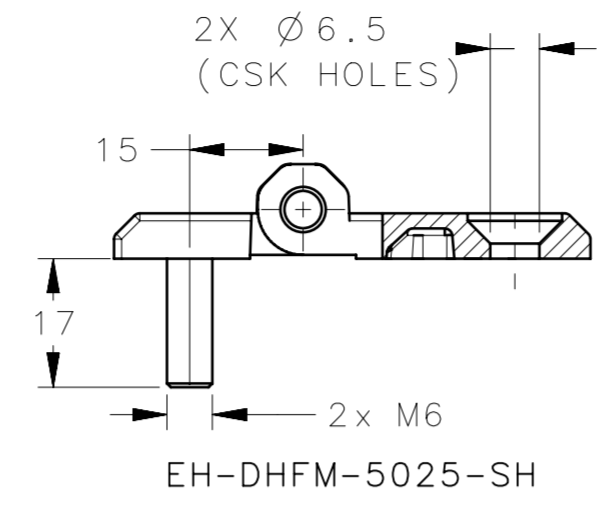

4X Ø 6.5 ± 0.1
PANEL PREPRATION

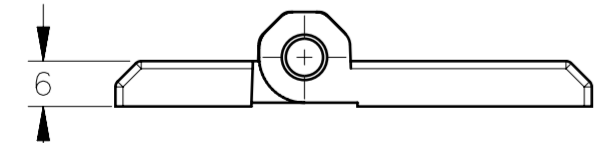
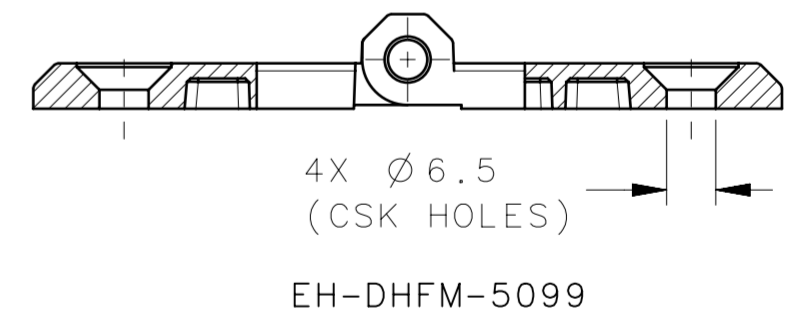
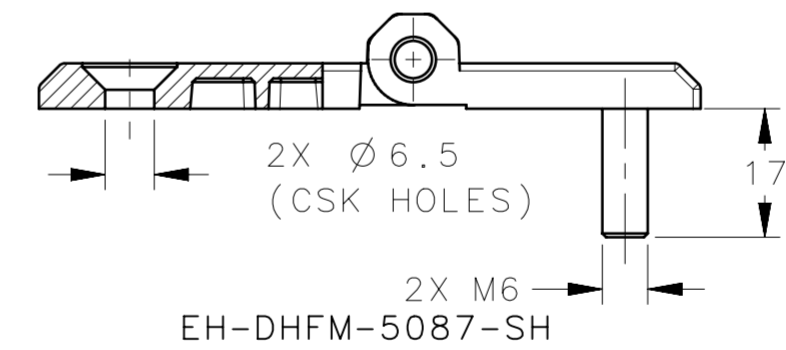
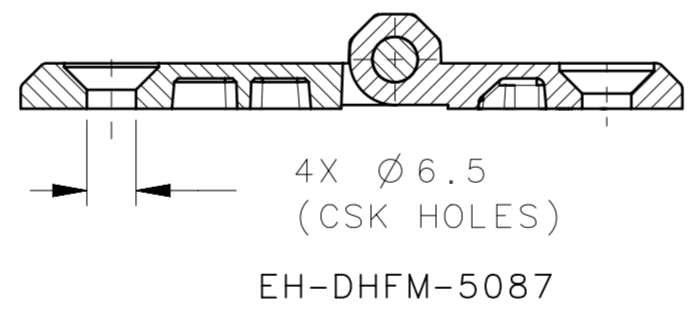
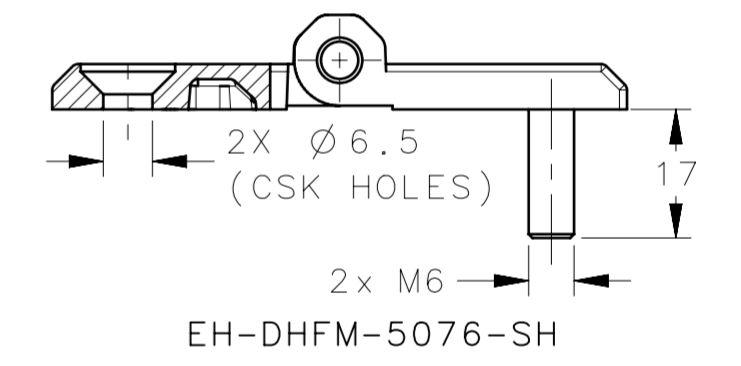
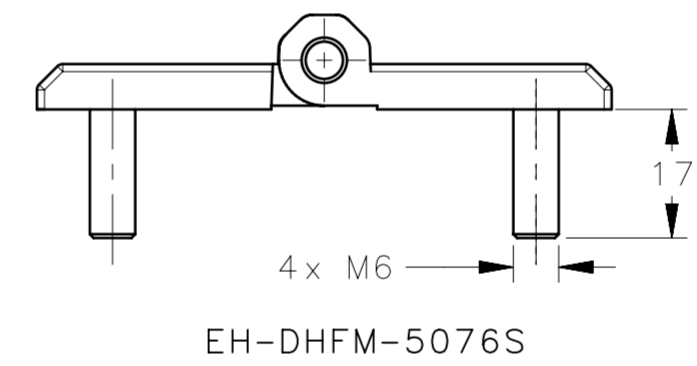
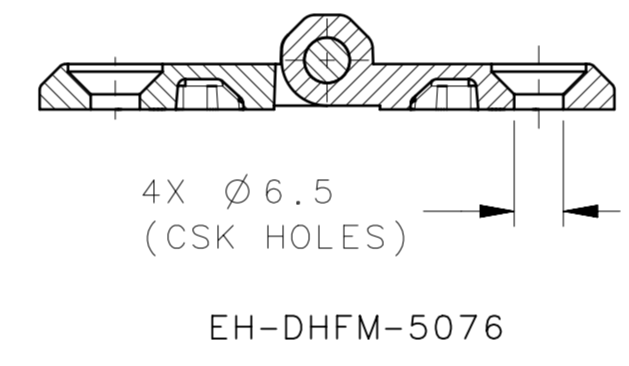

SHOWN PART NO
EH-DHFM-5063

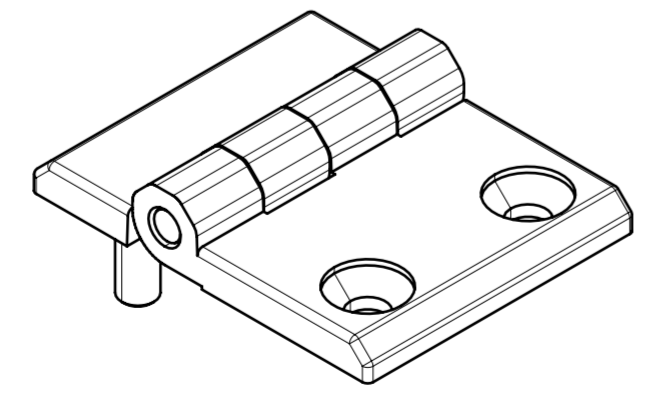

SHOWN PART NO
EH-DHFM-5025-SH

- NOTES:-
1. MOUNTING SCREWS NOT SUPPLIED.
 2. OPENING ANGLE 180°.

EH-DHFM-5025-SH	FLAT HINGE , (STUD + CSK HOLE)	ZINC DIE CAST	BLACK POWDER COATED	63	43	28
EH-DHFM-5032-SH	FLAT HINGE , (CSK HOLE + STUD)	ZINC DIE CAST	BLACK POWDER COATED	63	43	28
EH-DHFM-5063	FLAT HINGE , (CSK HOLE + CSK HOLE)	ZINC DIE CAST	BLACK POWDER COATED	63	43	28
EH-DHFM-5063S	FLAT HINGE , (STUD + STUD)	ZINC DIE CAST	BLACK POWDER COATED	63	43	28
EH-DHFM-5074	FLAT HINGE , (CSK HOLE + CSK HOLE)	ZINC DIE CAST	BLACK POWDER COATED	74.5	52.5	37.5
EH-DHFM-5074-SH	FLAT HINGE , (STUD + CSK HOLE)	ZINC DIE CAST	BLACK POWDER COATED	74.5	52.5	37.5
EH-DHFM-5076	FLAT HINGE , (CSK HOLE + CSK HOLE)	ZINC DIE CAST	BLACK POWDER COATED	76	56	28
EH-DHFM-5076S	FLAT HINGE , (STUD + STUD)	ZINC DIE CAST	BLACK POWDER COATED	76	56	28
EH-DHFM-5076-SH	FLAT HINGE , (CSK HOLE + STUD)	ZINC DIE CAST	BLACK POWDER COATED	76	56	28
EH-DHFM-5087	FLAT HINGE , (CSK HOLE + CSK HOLE)	ZINC DIE CAST	BLACK POWDER COATED	87.5	65.5	28
EH-DHFM-5087-SH	FLAT HINGE , (CSK HOLE + STUD)	ZINC DIE CAST	BLACK POWDER COATED	87.5	65.5	28
EH-DHFM-5099	FLAT HINGE , (CSK HOLE + CSK HOLE)	ZINC DIE CAST	BLACK POWDER COATED	99	75	37.5
SOUTHCO PART NUMBER	DESCRIPTION	MATERIAL	FINISH	AA	BB	CC

CPB NUMBER 2024-0676	THIRD ANGLE PROJECTION		southco CONNECT · CREATE · INNOVATE
	MILLIMETERS [IN]		
SURFACE AREA XXXXXmm ²	TOLERANCES UNLESS OTHERWISE NOTED		DESCRIPTION FLAT HINGE
VOLUME XXXXXmm ³	ALL DIMENSIONS WITHOUT TOLERANCES ARE FOR REFERENCE ONLY.		SIZE SYSTEM A2 NX
PROPRIETARY ITEM EXCEPT FOR USES EXPRESSLY GRANTED IN WRITING, INFORMATION DISCLOSED HEREON IS CONFIDENTIAL AND ALL RIGHTS, PATENT AND OTHERWISE, ARE RESERVED BY SOUTHCO, INC.	PER ASME Y14.5M-2009	DRAWN BY SBK	DATE 25JULY2024
		SCALE 1:1	SHEET 1 OF 1

DWG NO. J-EH-DHFM-5	
------------------------	--