

NOTES:
 A. MATERIAL AND FINISH:
 HOUSINGS: GLASS FILLED NYLON, SLIDE BOLT: ACETAL, INTERNAL COMPONENTS: ACETAL, AND METAL COMPONENTS
 B. ELECTRICAL SPECIFICATIONS:
 OPERATING VOLTAGE: 5±0.5 VDC
 TYPICAL OPERATING CURRENT: LESS THAN 0.4A, PEAK / STALL CURRENT: 0.5A MAX
 TOTAL STANDBY CURRENT: RETRACTED: 0 AMPS, EXTENDED: 0 AMPS
CAUTION! NO STALL PROTECTION IS PROVIDED IN LATCH. USE APPROPRIATE CIRCUIT PROTECTION.
 OPERATING TEMPERATURE RANGE: 0°C TO 60°C NON-ICING, NON-CONDENSING ENVIRONMENT
 OPERATING HUMIDITY: 85% MAX.
 NOT INTENDED FOR DIRECT EXPOSURE TO OUTDOOR ELEMENTS.

C. ELECTRICAL CONNECTIONS AND HOOKUP:
 A BASIC SPDT SWITCH CONTROL ELECTRICAL HOOKUP DIAGRAM IS PROVIDED FOR REFERENCE.
 CONSULT WITH A SOUTHCO REPRESENTATIVE FOR ADDITIONAL ELECTRICAL HOOKUP INFORMATION.
 - CONNECT GROUND, AND CONTROL SIGNAL WIRES TO AN APPROPRIATE CONTROLLER AND DC POWER SUPPLY
 - A DC POWER SUPPLY CAPABLE OF SUPPLYING 5±0.5 VDC AT 1 AMP MINIMUM PER LATCH IS RECOMMENDED
 - POWER MUST BE AVAILABLE TO OPERATE THE LATCH AND MUST REMAIN AVAILABLE DURING THE FULL TRANSIT TIME OF THE LATCH DURING EXTENDING OR RETRACTING.
CAUTION! LATCH CAN BE DAMAGED IF WIRED INCORRECTLY, OR IF IMPROPER VOLTAGE IS APPLIED!
 WIRE COLOR CODE / CONNECTOR PIN ASSIGNMENT: SEE CONNECTOR PINOUT LOCATION DETAILS
 PIN1/BROWN WIRE: GROUND(-)
 PIN2/RED WIRE: LATCH BOLT EXTENDED +5V
 PIN3/ORANGE WIRE: LATCH BOLT RETRACTED +5V

D. ELECTRICAL OPERATION:
 TO OPERATE THE LATCH IN TWO POSITION MODE:
 -FOR EXTENDED(LOCKED) POSITION: APPLY +5 VDC TO RED WIRE FOR A MINIMUM OF 600ms, THE ORANGE WIRE SHOULD NOT BE CONNECTED(OPEN CIRCUIT)
 THE LATCH WILL TRANSIT TO THE EXTENDED POSITION ONCE AND STAY THERE.
 FROM THE EXTENDED (LOCKED)POSITION, THE DOOR CAN BE PUSHED TO CLOSE AND WILL LOCK.
 -FOR RETRACTED POSITION: APPLY +5 VDC TO ORANGE WIRE FOR A MINIMUM OF 600ms, THE RED WIRE SHOULD NOT BE CONNECTED(OPEN CIRCUIT)
 THE LATCH WILL TRANSIT TO THE RETRACTED POSITION ONCE AND STAY THERE.
CAUTION! TO PREVENT LONG TERM DAMAGE TO THE ELECTRICAL COMPONENTS IT IS IMPORTANT TO NOT STALL THE SLIDE BOLT DURING ELECTRICAL OPERATION. IT IS RECOMMENDED TO LIMIT POWER ON TIME FOR EITHER POSITION TO 1.5 SECONDS MAX.
 - THE LATCH CANNOT REVERSE A CYCLE.
 - THE LATCH MUST BE ALLOWED TO REACH ITS FULLY RETRACTED TRAVEL TO COMPLETE A CYCLE.
 - SEE TECHNICAL DATA SHEET FOR CYCLE LOAD AND MAXIMUM OPERATING LOAD.

ALTERNATE ELECTRICAL OPERATION:
 TO OPERATE THE LATCH IN TRIGGER MODE:
 -WHEN OPERATED IN TRIGGER MODE THE LATCH WILL FULLY RETRACT AND THEN IMMEDIATELY EXTEND
 CONNECT BROWN WIRE TO GROUND(-), CONNECT RED WIRE TO +5VDC, PROVIDE A +5VDC CONTROL PULSE TO ORANGE WIRE.
 CONTROL SIGNAL PULSE REQUIRED ON ORANGE WIRE FOR TRIGGER MODE: 5 VDC +/-10%, 0.5A MAX
 RECOMMENDED PULSE DURATION 300 +/- 25 MILLISECONDS (ORANGE WIRE)
 IT IS RECOMMENDED TO LIMIT POWER ON TIME TO 1.5 SECONDS MAX FOR STALLED MOTOR PROTECTION (RED WIRE).

NOTE: NO MECHANICAL OVERRIDE IS PROVIDED WITHIN THE LATCH. MECHANICAL OVERRIDE FEATURES OR ACCESS TO THE LATCH SHOULD BE CONSIDERED IN CASE OF LOSS OF POWER.

E. OPTIONAL CONNECTOR:
 MANUFACTURER: MOLEX, SERIES: MICROFIT 3.0
 - CONNECTOR RECEPTICAL, SINGLE ROW, 3 CIRCUITS, 3mm, MOLEX P/N: 43645-0300
 - CONTACTS: FEMALE CRIMP TERMINAL (SOCKET) MOLEX P/N: 43030-0004
 WIRE: 26 AWG STYLE UL1007/1569
 MATE FOR CONNECTOR (NOT SUPPLIED)
 MANUFACTURER: MOLEX, SERIES: MICROFIT 3.0
 - CONNECTOR PLUG 3 CIRCUITS 3 mm, MOLEX P/N: 43640-0301
 - RECOMMENDED CONTACTS (3 REQUIRED): MOLEX, MALE CRIMP TERMINAL (PIN), MOLEX P/N: 43031-0007
 - RECOMMENDED WIRE GAGE: 24 AWG

F. MOUNTING:
 -TWO Ø3.3MM THROUGH HOLES ARE PROVIDED FOR THROUGH HOLE MOUNTING WITH M3 OR 4-40 BOLTS. (NOT SUPPLIED)
 -MAXIMUM ALLOWABLE TORQUE ON THROUGH HOLE M3 OR 4-40 SOCKET HEAD CAP SCREWS 60 N.cm [5.3 in.lb]

G. PACKAGED IN INDIVIDUAL BAGS OR ADD -1 TO PART NUMBER FOR BULK PACKAGING, ADD SYMBOL TO PACKAGE:
 EXAMPLE: EM-05-52-2001 INDIVIDUAL PACKAGE
 EM-05-52-2001-1 BULK PACKAGE

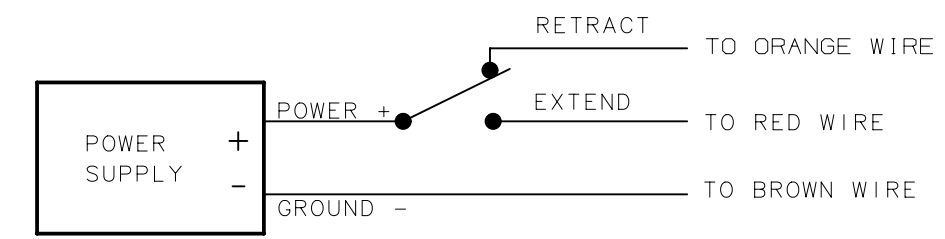
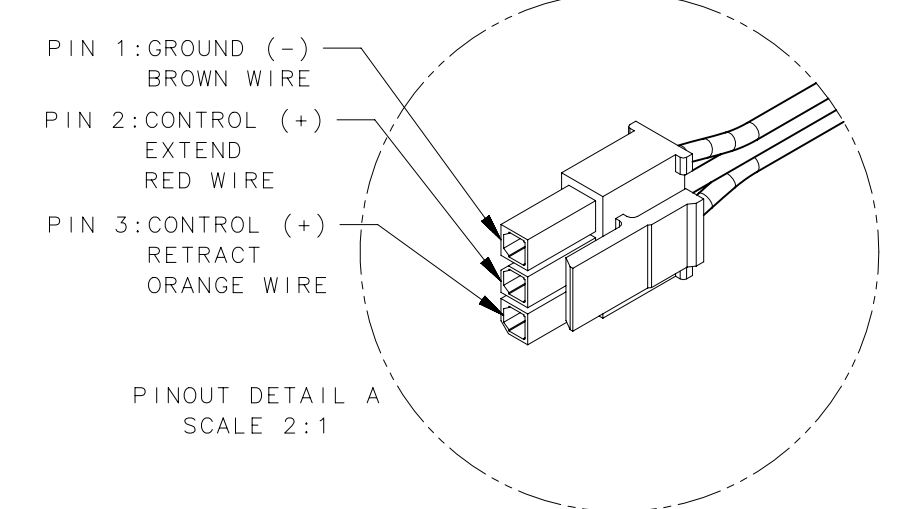

TWO POSITION MODE ELECTRICAL HOOKUP (SPDT SWITCH CONTROL)

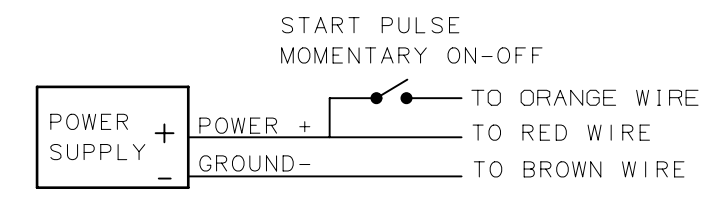

TRIGGER MODE ALTERNATE ELECTRICAL HOOKUP (START PULSE CONTROL)

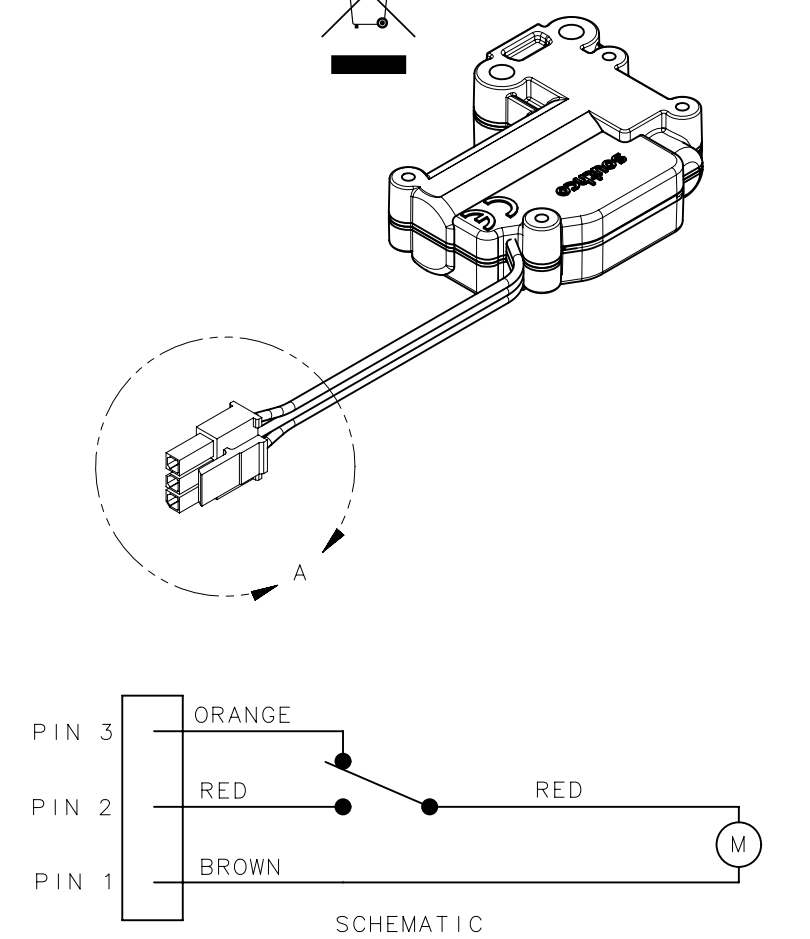

ELECTRO-MECHANICAL SLIDE BOLT SHOWN LATCH BOLT EXTENDED

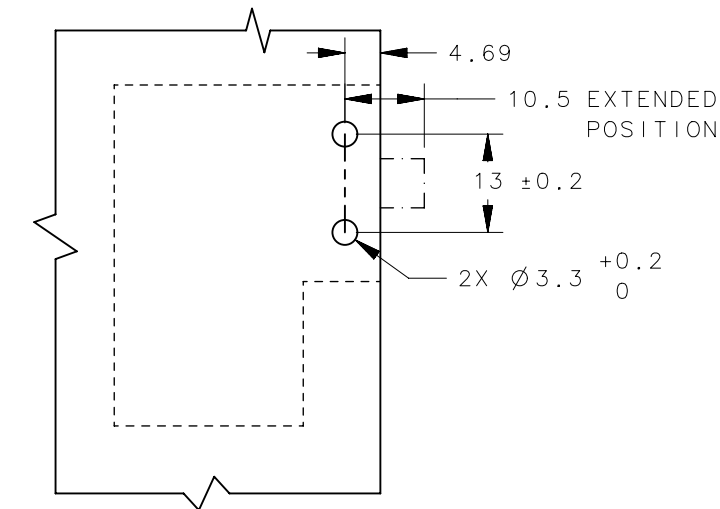
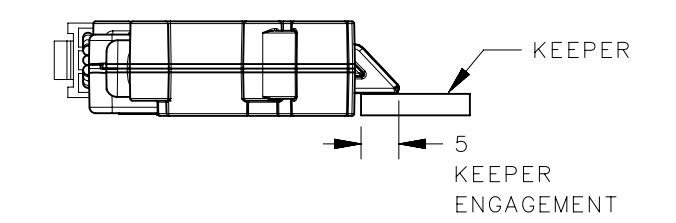

PANEL PREPARATION

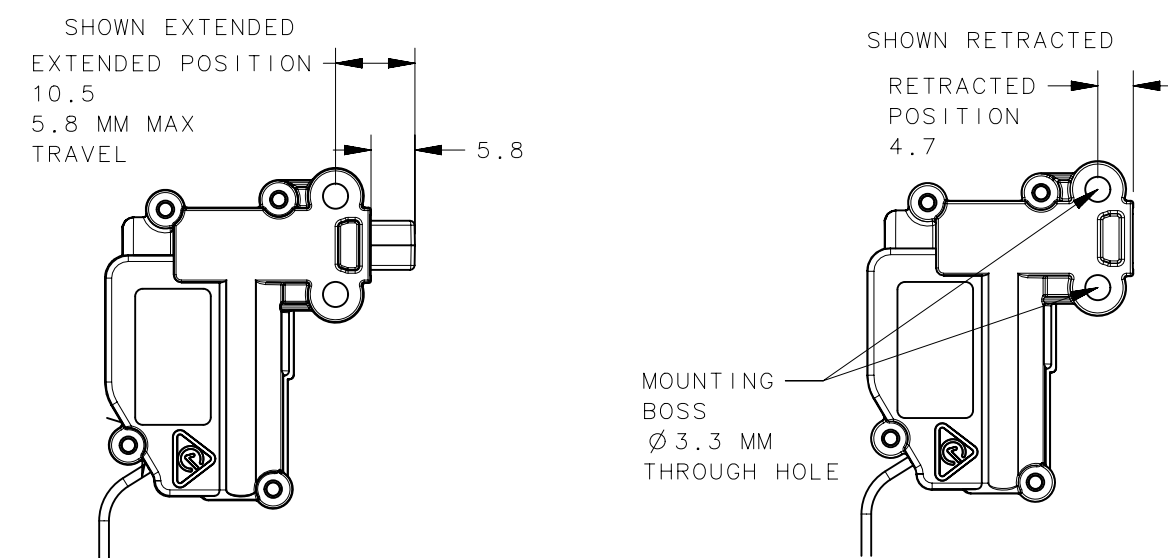

EM-05-52-2002 SHOWN

EM-05-55-2002	5V, ELECTRO-MECHANICAL SLIDE BOLT, RH, STRIPPED AND TINNED
EM-05-55-2001	5V, ELECTRO-MECHANICAL SLIDE BOLT, RH, WITH CONNECTOR
EM-05-54-2002	5V, ELECTRO-MECHANICAL SLIDE BOLT, LH, STRIPPED AND TINNED
EM-05-54-2001	5V, ELECTRO-MECHANICAL SLIDE BOLT, LH, WITH CONNECTOR
EM-05-53-2002	5V, ELECTRO-MECHANICAL SLIDE BOLT, UP, STRIPPED AND TINNED
EM-05-53-2001	5V, ELECTRO-MECHANICAL SLIDE BOLT, UP, WITH CONNECTOR
EM-05-52-2002	5V, ELECTRO-MECHANICAL SLIDE BOLT, DOWN, STRIPPED AND TINNED
EM-05-52-2001	5V, ELECTRO-MECHANICAL SLIDE BOLT, DOWN, WITH CONNECTOR
ASSEMBLY PART NUMBER DESCRIPTION	

THIRD ANGLE PROJECTION		 CONNECT · CREATE · INNOVATE	
MILLIMETERS [IN]			
SURFACE AREA XXXXXmm ²		DESCRIPTION	
VOLUME XXXXXmm ³		ELECTRONIC ACCESS SLIDE BOLT	
PROPRIETARY ITEM		ELECTRO-MECHANICAL SLIDE BOLT	
EXCEPT FOR USES EXPRESSLY GRANTED IN WRITING, INFORMATION DISCLOSED HEREON IS CONFIDENTIAL AND ALL RIGHTS, PATENT AND OTHERWISE, ARE RESERVED BY SOUTHCO, INC.		SIZE SYSTEM A2 NX	DWG NO. J-EM-05-5-1
PER ASME Y14.5M-1994		DRAWN BY GGG	DATE 04MAY2017
		SCALE 1:1	SHEET 1 OF 2

REVISION HISTORY			
REV	DATE	BY	DESCRIPTION
F	10MAR2020	JCS/DJK	PRN: P2020-0428

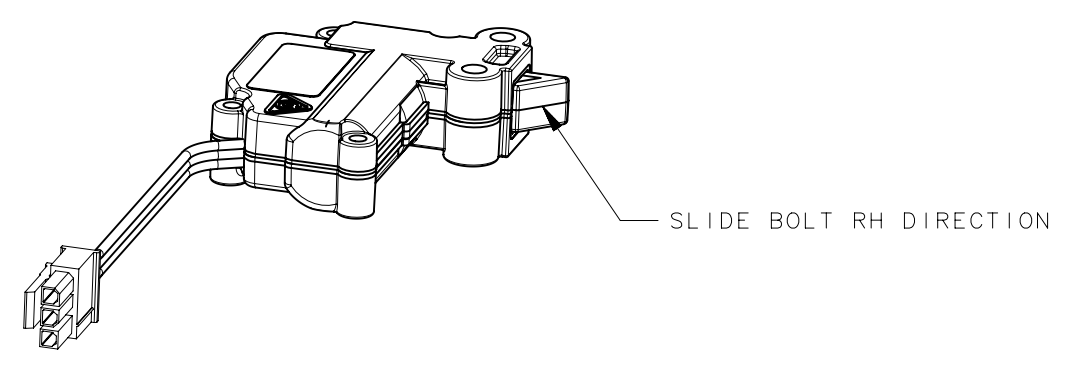
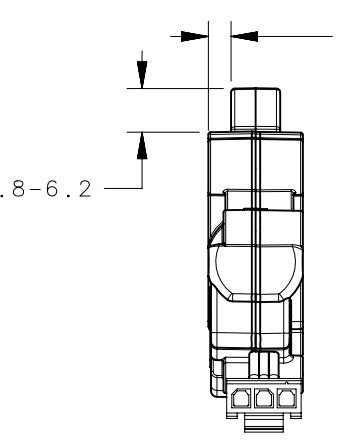
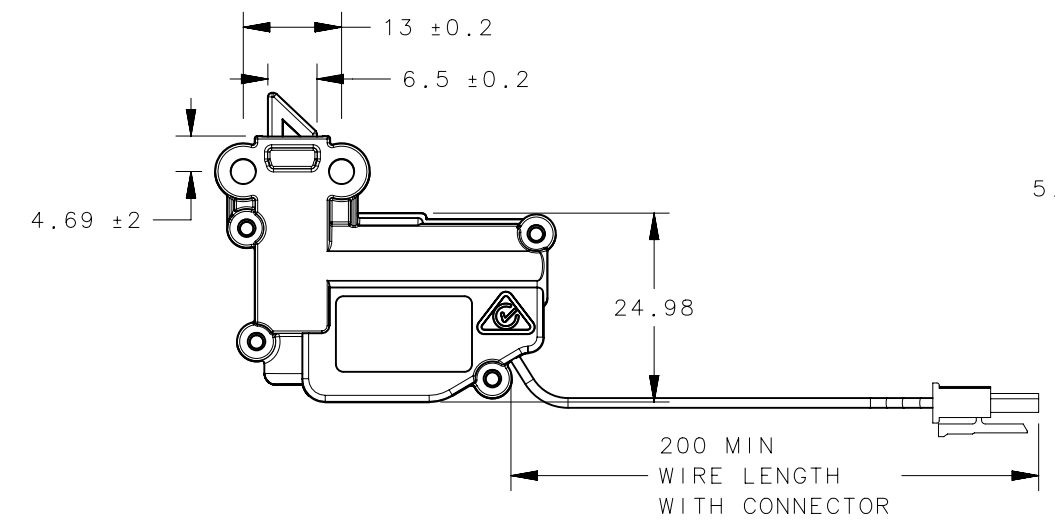
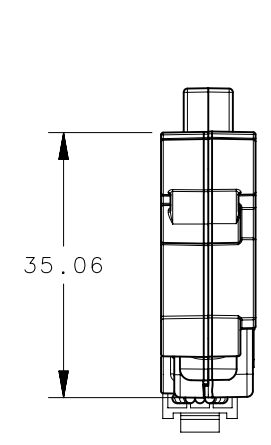

EM-05-55-2001, ELECTRO-MECHANICAL SLIDE BOLT LATCH BOLT RH, WITH CONNECTOR

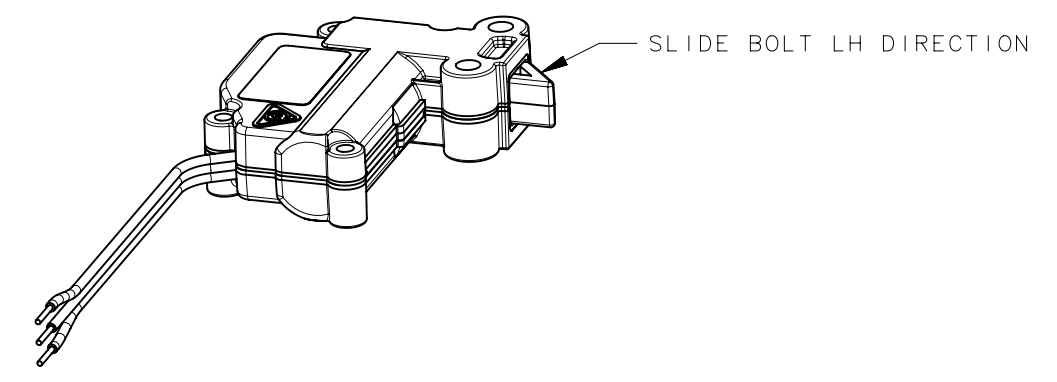
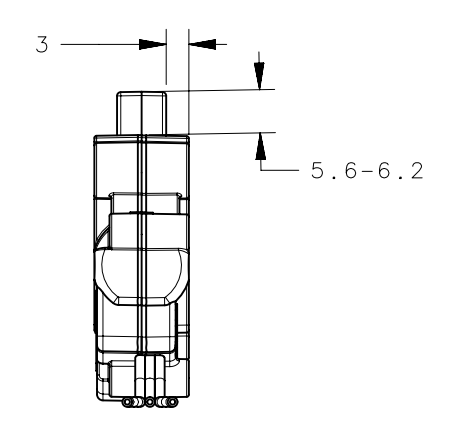
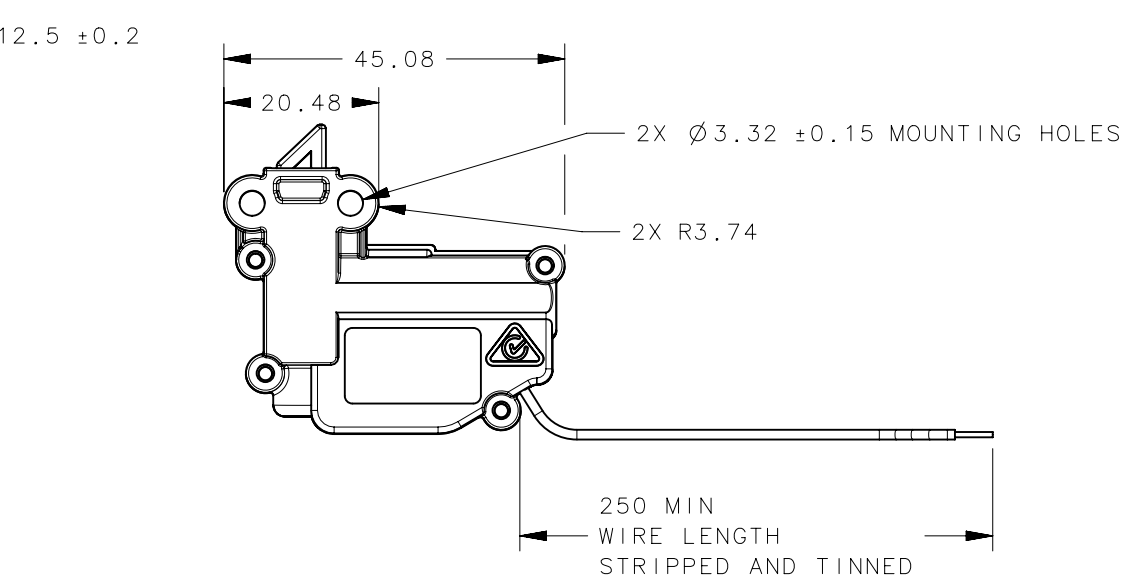
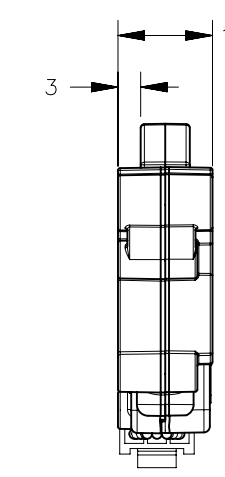

EM-05-54-2002, ELECTRO-MECHANICAL SLIDE BOLT LATCH BOLT LH, STRIPPED AND TINNED

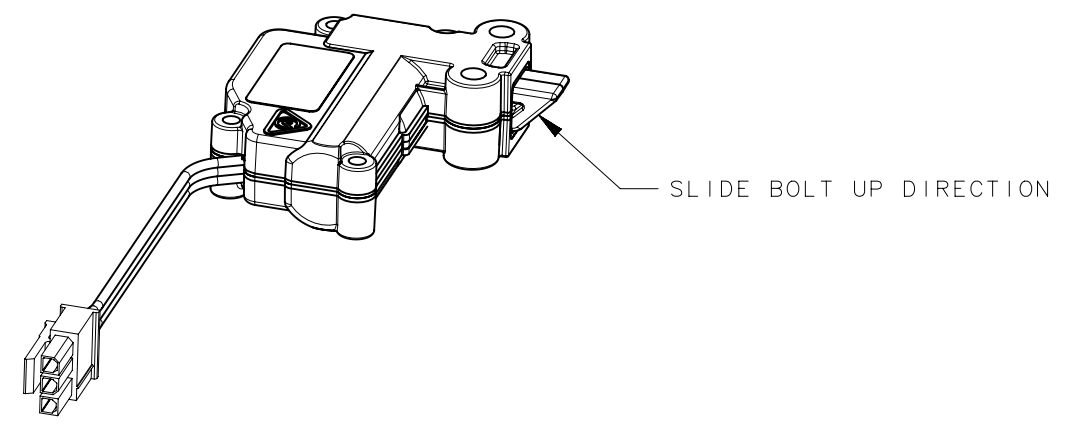
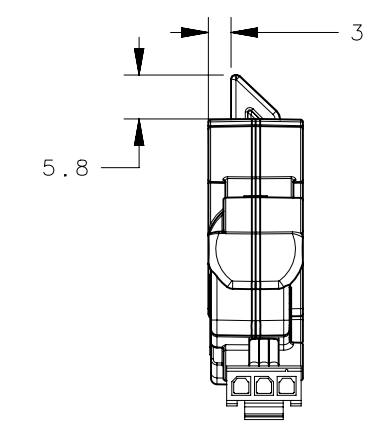
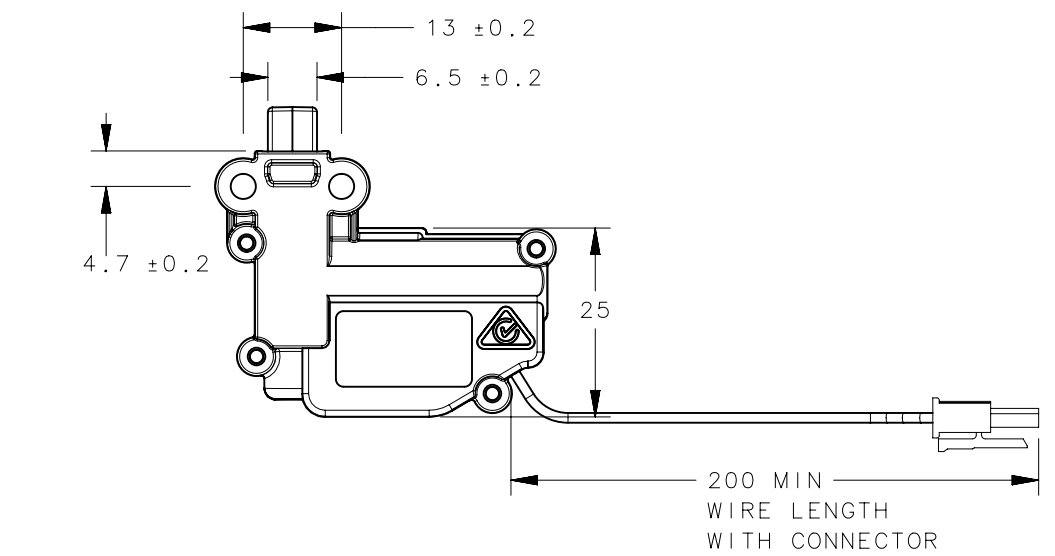
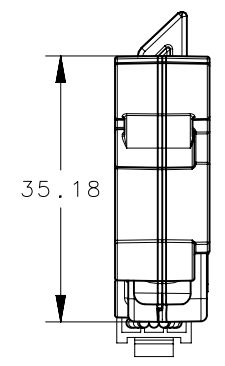

EM-05-53-2001, ELECTRO-MECHANICAL SLIDE BOLT LATCH BOLT UP DIRECTION, WITH CONNECTOR

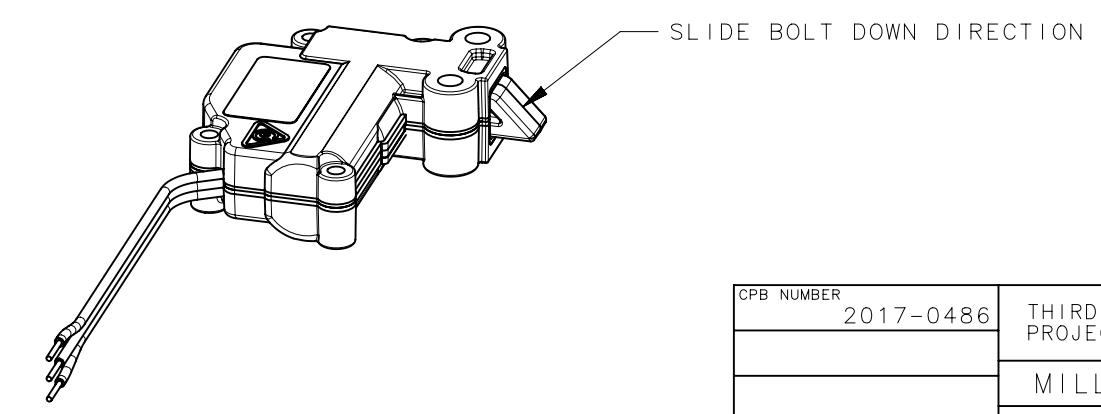
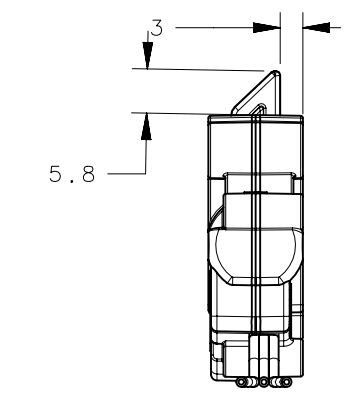
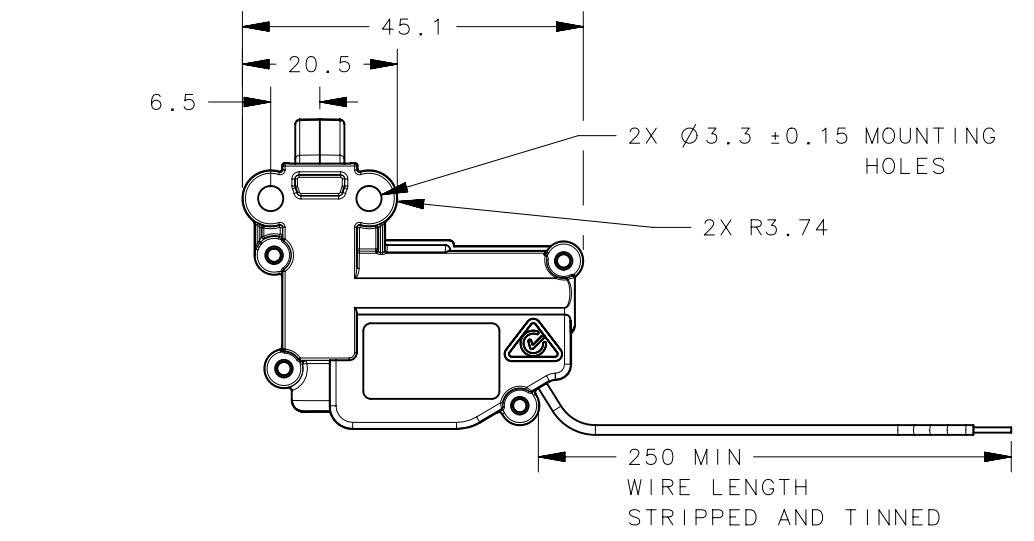
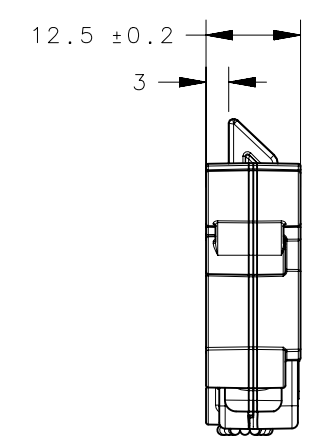

EM-05-52-2002, ELECTRO-MECHANICAL SLIDE BOLT LATCH BOLT DOWN DIRECTION, STRIPPED AND TINNED

CPB NUMBER	2017-0486	THIRD ANGLE PROJECTION			southco CONNECT · CREATE · INNOVATE	
		MILLIMETERS [IN]				
SURFACE AREA	mm ²	TOLERANCES UNLESS OTHERWISE NOTED		DESCRIPTION		
VOLUME	mm ³	ALL DIMENSIONS WITHOUT TOLERANCES ARE FOR REFERENCE ONLY.		ELECTRONIC ACCESS SOLUTION ELECTRO-MECHANICAL SLIDE BOLT		
PROPRIETARY ITEM	EXCEPT FOR USES EXPRESSLY GRANTED IN WRITING, INFORMATION DISCLOSED HEREON IS CONFIDENTIAL AND ALL RIGHTS, PATENT AND OTHERWISE, ARE RESERVED BY SOUTHCO, INC.		SIZE	SYSTEM	DWG NO.	
	PER ASME Y14.5M-1994	A2	NX	J-EM-05-5-1		
		DRAWN BY	DATE	SCALE	SHEET	
		GGG	04MAY2017	1:1	2 OF 2	