

REVISION HISTORY			
REV	DATE	BY	DESCRIPTION
A	03JUL2024	SBK/VK	IPN: IP-2024-1602

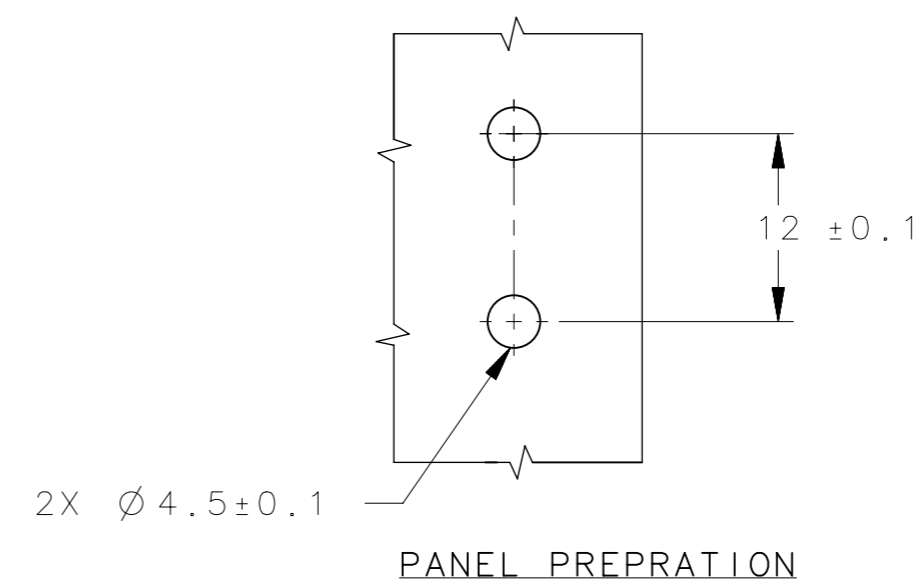

NOTES:-
 1. MOUNTING SCREWS NOT SUPPLIED.
 2. OPENING ANGLE 90°.

F6-DHIM-4015-AR	CORNER & REMOVABLE HINGES	MS	BLUE ZINC PLATED
F6-DHIM-4015-AR-SS	CORNER & REMOVABLE HINGES	304SS	ELECTRO POLISHING
SOUTHCO PART NUMBER		DESCRIPTION	
CPB NUMBER 2024-0167		THIRD ANGLE PROJECTION	
SURFACE AREA		MILLIMETERS [IN]	
VOLUME		TOLERANCES UNLESS OTHERWISE NOTED	
PROPRIETARY ITEM		ALL DIMENSIONS WITHOUT TOLERANCES ARE FOR REFERENCE ONLY.	
EXCEPT FOR USES EXPRESSLY GRANTED IN WRITING, INFORMATION DISCLOSED HEREON IS CONFIDENTIAL AND ALL RIGHTS, PATENT AND OTHERWISE, ARE RESERVED BY SOUTHCO, INC.		SIZE A3	SYSTEM NX
PER ASME Y14.5M-2009		DWG NO. J-F6-DHIM-4015-AR	DATE 23APR2024
DRAWN BY SBK		SCALE 1:1	SHEET 1 OF 1

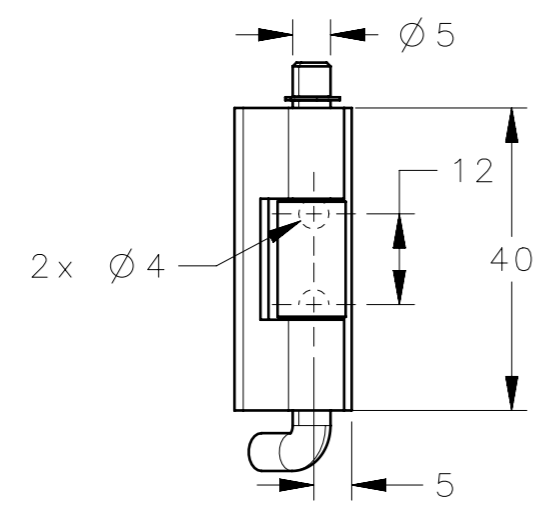
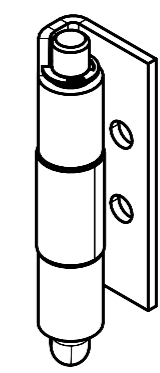
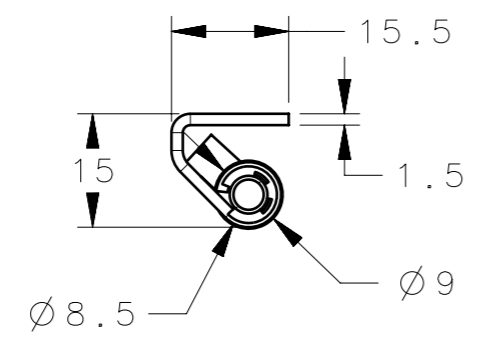

CORNER & REMOVABLE HINGES