

REVISION HISTORY			
REV	DATE	BY	DESCRIPTION
A	27NOV2014	DMS/YGC	PRN: P2014-2423

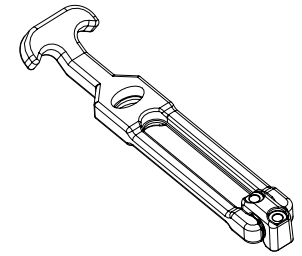

SCALE 1:4

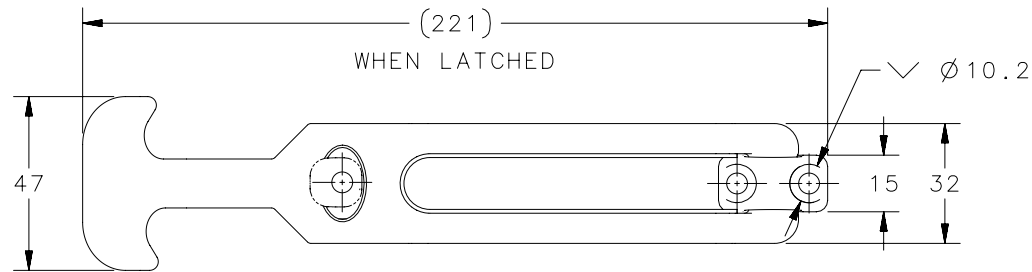
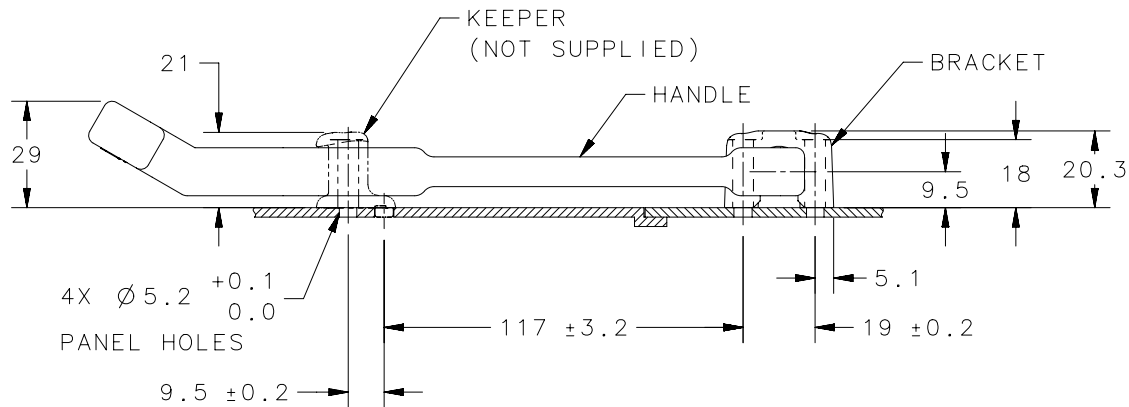

NO.	PART NUMBER	QTY	TYPE OF COMPONENT	MATERIAL	FINISH
2	-	1	HANDLE	T.P.E.	BLACK
1	-	1	BRACKET	G.R. NYLON	BLACK
-	F7-730	-	LATCH SUBASSEMBLY	-	-

NOTES:

1. MOUNT USING(3) M5 (NO.10), SCREWS OR Ø5(3/16) RIVETS (NOT SUPPLIED).
2. NOTED DIMENSIONS ARE NOT TO SCALE AND REPRESENT DISTANCE WHEN FLEXIBLE DRAW LATCH HANDLE IS STRETCHED TO LATCHED POSITION OVER THE KEEPER.

THIRD ANGLE PROJECTION		 CONNECT • CREATE • INNOVATE			
INCHES [MM]					
TOLERANCES UNLESS OTHERWISE NOTED		DESCRIPTION NUMBER F7 FLEXIBLE Draw Latch FRONT MOUNTING			
ALL DIMENSIONS WITHOUT TOLERANCES ARE FOR REFERENCE ONLY.		SIZE A	SYSTEM NX	DWG NO. J-F7-730	
PER ASME Y14.5M-1994		DRAWN BY DMS/YGC	DATE 27NOV2014	SCALE 1:2	SHEET 1 OF 1

PROPRIETARY ITEM  
EXCEPT FOR USES EXPRESSLY GRANTED IN WRITING, INFORMATION DISCLOSED HEREON IS CONFIDENTIAL AND ALL RIGHTS, PATENT AND OTHERWISE, ARE RESERVED BY SOUTHCO, INC.