

50 MINIMUM BENDING RADIUS

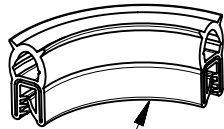

30 MINIMUM BENDING RADIUS

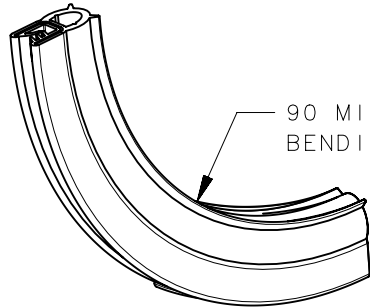

90 MINIMUM BENDING RADIUS

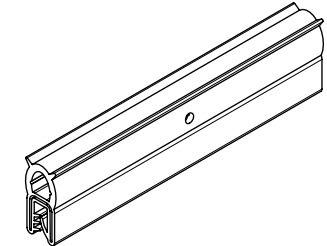
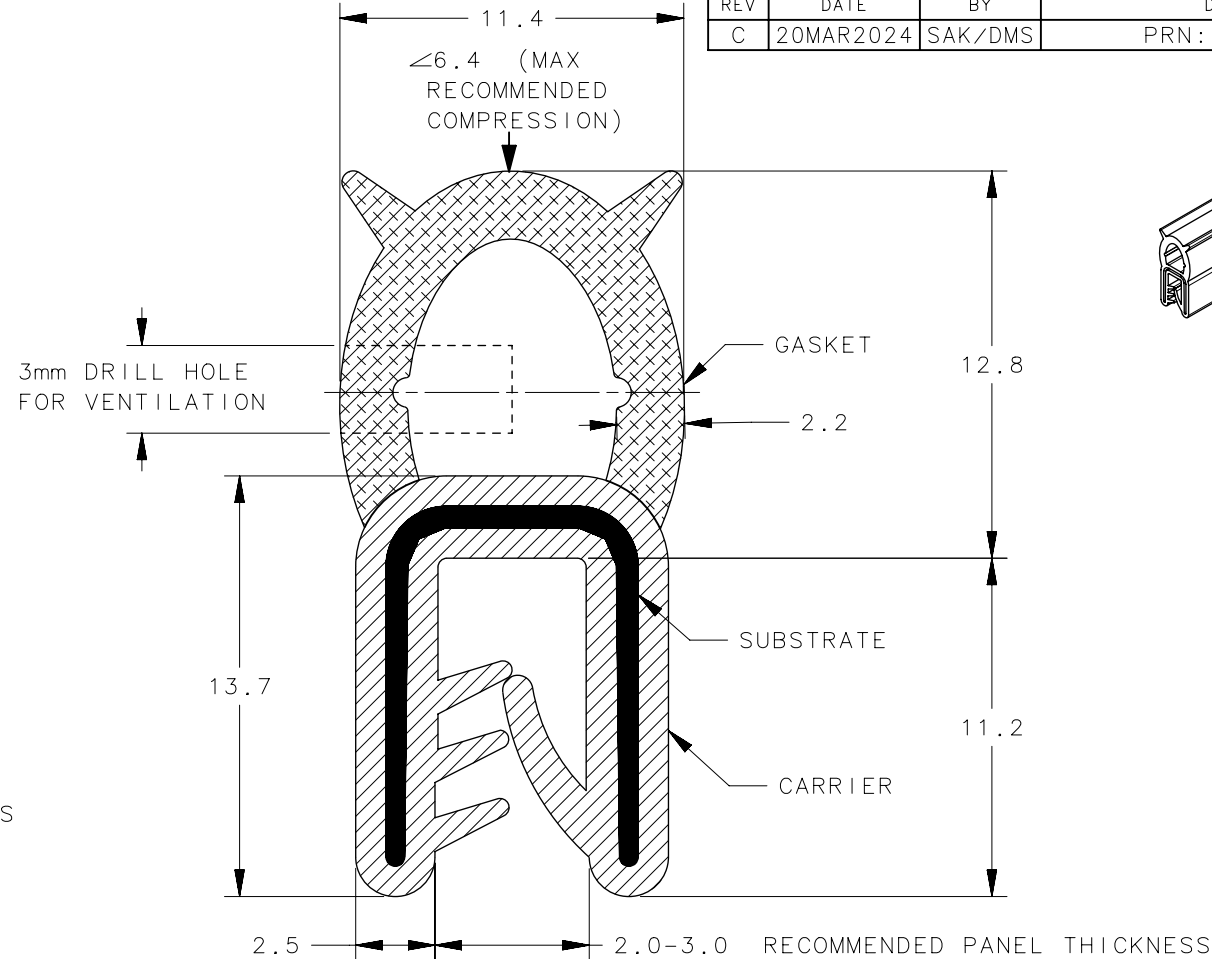

SCALE 1:2

REVISION HISTORY			
REV	DATE	BY	DESCRIPTION
C	20MAR2024	SAK/DMS	PRN: P2024-0507

- NOTES:
- A. MATERIAL
 - GASKET: EPDM SPONGE RUBBER, BLACK
 - CARRIER: 70 DUROMETER DENSE EPDM RUBBER, BLACK
 - B. COMPLIES WITH UL 94-HB (FLAMMABILITY RATING)
 - COMPLIES WITH UL JMLU2 (GASKETS AND SEALS)
 - C. FORCE TO COMPRESS 100mm LENGTH OF GASKET:
 - BY 30% (3.8 MM): 5.8 LBS (25.8 N)
 - BY 50% (6.4 MM): 8.2 LBS (36.5 N)

GA-010-82-M500	50	NON-VENTED
GA-010-82V-M500	50	VENTED
GA-010-82-M030	3	NON-VENTED
GA-010-82V-M030	3	VENTED
PART NUMBER	LENGTH (METERS)	VENTING

STANDARD	THIRD ANGLE PROJECTION			 CONNECT • CREATE • INNOVATE	
	MILLIMETERS [IN]				
	TOLERANCES UNLESS OTHERWISE NOTED	DESCRIPTION			
	ALL DIMENSIONS WITHOUT TOLERANCES ARE FOR REFERENCE ONLY.	GASKET, CLIP-ON SEALING PROFILE 010			
PROPRIETARY ITEM	PER ASME Y14.5M-2009	SIZE A4	SYSTEM NX	DWG NO. J-GA-010	
EXCEPT FOR USES EXPRESSLY GRANTED IN WRITING, INFORMATION DISCLOSED HEREON IS CONFIDENTIAL AND ALL RIGHTS, PATENT AND OTHERWISE, ARE RESERVED BY SOUTHCO, INC.		DRAWN BY CMS/IR	DATE 07MAR2022	SCALE 4:1	SHEET 1 OF 1