

MIFARE® Classic and MIFARE® DESFire® are trademarks of NXP B.V.
 HID® and iCLASS® are registered trademark of HID Global (Patented, www.hidglobal.com/patents)

REVISION HISTORY			
REV	DATE	BY	DESCRIPTION
I	22JUN2023	DPZ/CMS	PRN:P2023-1257

NOTES:

- MIN GRIP RANGE WITH FLAT CAM 15.5mm [.61]
 EXAMPLE SHOWN: 2mm OFFSET CAM - GRIP RANGE 17.5mm [.68]
- FOR CAM LENGTH 38mm [1.5] -EDGE DISTANCE 30mm [1.18]
 FOR CAM LENGTH 45mm [1.77] -EDGE DISTANCE 37mm [1.46]
- SELECT CAM PART NUMBERS ACCORDING TO TABLE TO PROVIDE GRIP REQUIRED.

CAM PART NUMBER (ORDER SEPERATELY)		
GRIP	CAM LENGTH (1) 38 MM [1.5]	CAM LENGTH (2) 45 MM [1.77]
15.5 [.61]	E5-6710	-
17.5 [.68]	E5-6711	-
19.5 [.76]	E5-6712	E5-6112
21.5 [.85]	E5-6713	E5-6113
23.5 [.93]	E5-6714	E5-6114

OTHER ADDITIONAL OFFSETS:
 (1) SEE SOUTHCO DRAWINGS J-E5-67-A & J-E5-67-B
 (2) SEE SOUTHCO DRAWINGS J-E5-61-A

- THE H3-EM-64-000 IS SHIPPED WITHOUT A LOCKPLUG. THIS PRODUCT MUST BE PAIRED WITH A SOUTHCO APPROVED LOCK TO FUNCTION PROPERLY. USE WITH AN UNAPPROVED LOCK PLUG VOIDS THE PRODUCT WARRANTY.

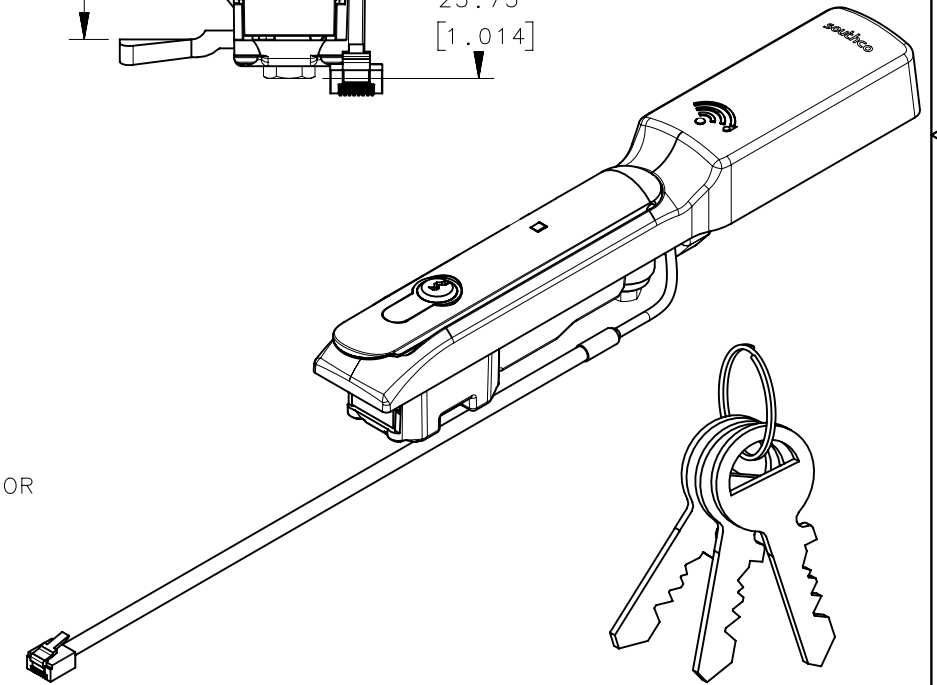
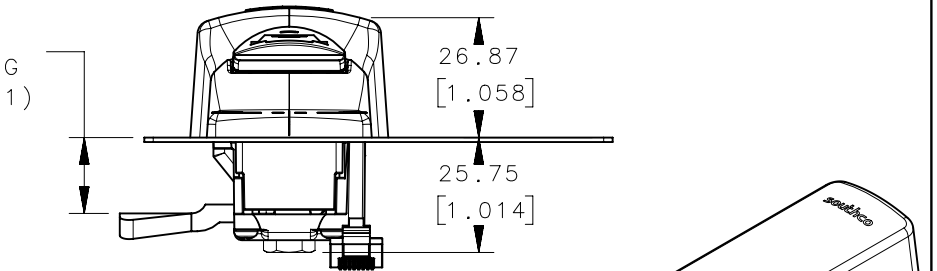
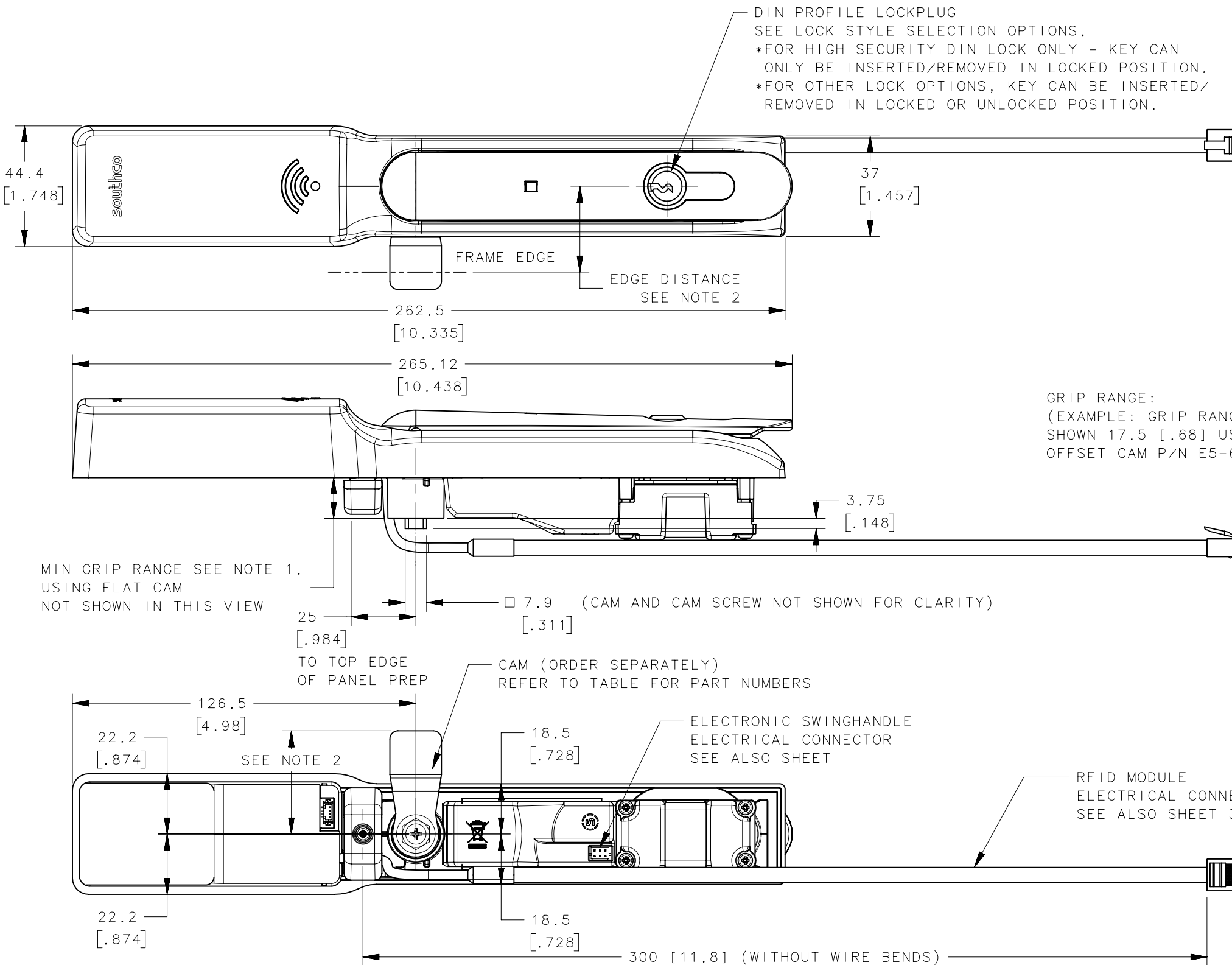

KEYS INCLUDED
 (EXCEPT FOR NO LOCK PLUG
 AND BLANK LOCK PLUG
 VERSIONS)

ELECTRONIC SWINGHANDLE PART NUMBER SELECTION
H3-EM-64-LLL-XX-P

SEE OPERATIONAL INSTRUCTIONS FOR DEFAULT COMPATIBLE CARDS

- LLL LOCK STYLE
- 000 NO LOCK OR KEYS
- 001 BLANK LOCKPLUG: BRIGHT CHROME
- 100 HIGH SECURITY DIN LOCK (3 KEYS)
- 200 KEY CODE CH-751 (2 KEYS INCLUDED)
- 3LL KEY CODE RS001 (2 KEYS INCLUDED)
- LL = 00 FOR KEY CODE RS001
- CONTACT SOUTHCO FOR OTHER AVAILABLE KEY CODES)
- 1 = BULK PACKAGE
- XX LOGO STYLE
- NONE NO LOGO
- 10 SOUTHCO LOGO

THIRD ANGLE PROJECTION	MILLIMETERS [IN]		
	TOLERANCES UNLESS OTHERWISE NOTED		
ALL DIMENSIONS WITHOUT TOLERANCES ARE FOR REFERENCE ONLY.		DESCRIPTION	H3-EM ELECTRONIC SWINGHANDLE HIGH FREQUENCY
PROPRIETARY ITEM	SIZE A3	SYSTEM NX	DWG NO. J-H3-EM-64-1
EXCEPT FOR USES EXPRESSLY GRANTED IN WRITING, INFORMATION DISCLOSED HEREON IS CONFIDENTIAL AND ALL RIGHTS, PATENT AND OTHERWISE, ARE RESERVED BY SOUTHCO, INC.	PER ASME Y14.5M-1994	DRAWN BY DJK	DATE 08OCT2014 SCALE NTS SHEET 1 OF 4

REVISION HISTORY			
REV	DATE	BY	DESCRIPTION
1	22JUN2023	DPZ/CMS	PRN:P2023-1257

CAUTION: SECURE WIRES SUCH THAT THEY DO NOT INTERFERE WITH LATCH CAM AND LOCK PLUG

CHECK THAT THE WIRES ARE NOT PINCHED BETWEEN THE LATCH HOUSING, PANEL AND TOP MOUNTING BRACKET

ROTATION LIMITER: (LEFT HAND MOUNTING SHOWN)
 SELECT THIN ROTATION LIMITER FOR STANDARD APPLICATIONS
 USE THICK ROTATION LIMITER FOR ADDITIONAL CLEARANCE AS REQUIRED ON MULTI POINT SYSTEMS
 ORIENTATION ACCORDING TO REQUIRED HANDLE OPERATION (LEFT OR RIGHT HANDED MOUNTING)

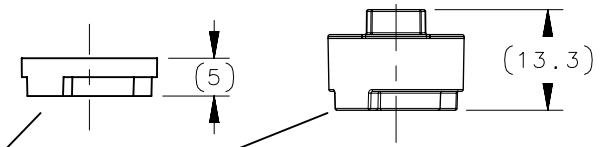

OPTION 1 FOR INSTALLATION OF ROTATION LIMITER - VIEWED FROM BACK-

OPTION 2 FOR INSTALLATION OF ROTATION LIMITER - VIEWED FROM BACK-

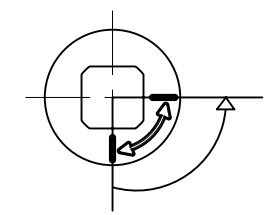
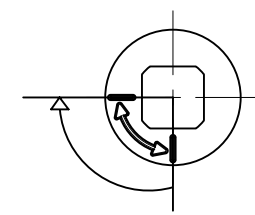

LEFT HAND MOUNTING
 TO OPEN: TURN HANDLE 90° COUNTER CLOCKWISE IF VIEWED FROM FRONT

RIGHT HAND MOUNTING
 TO OPEN: TURN HANDLE 90° CLOCKWISE IF VIEWED FROM FRONT

INSTALLATION OF BOTTOM MOUNTING BRACKET

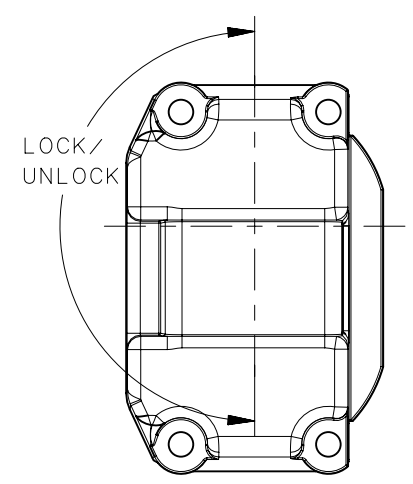
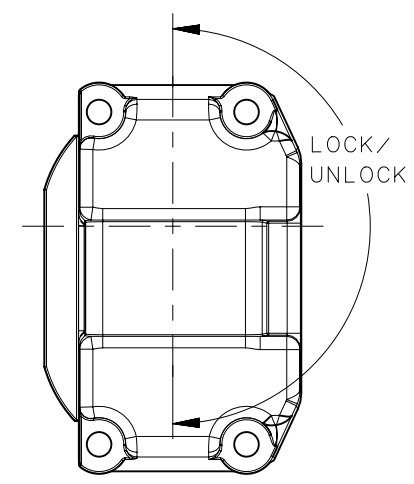

OPERATION OF LOCK PLUG CORRESPONDS WITH ORIENTATION OF BOTTOM MOUNTING BRACKET

LEFT HAND MOUNT
 WHEN H3-61-55-33 MULTI POINT SYSTEM IS USED.

RIGHT HAND MOUNT
 WHEN H3-61-56-33 MULTI POINT SYSTEM IS USED.

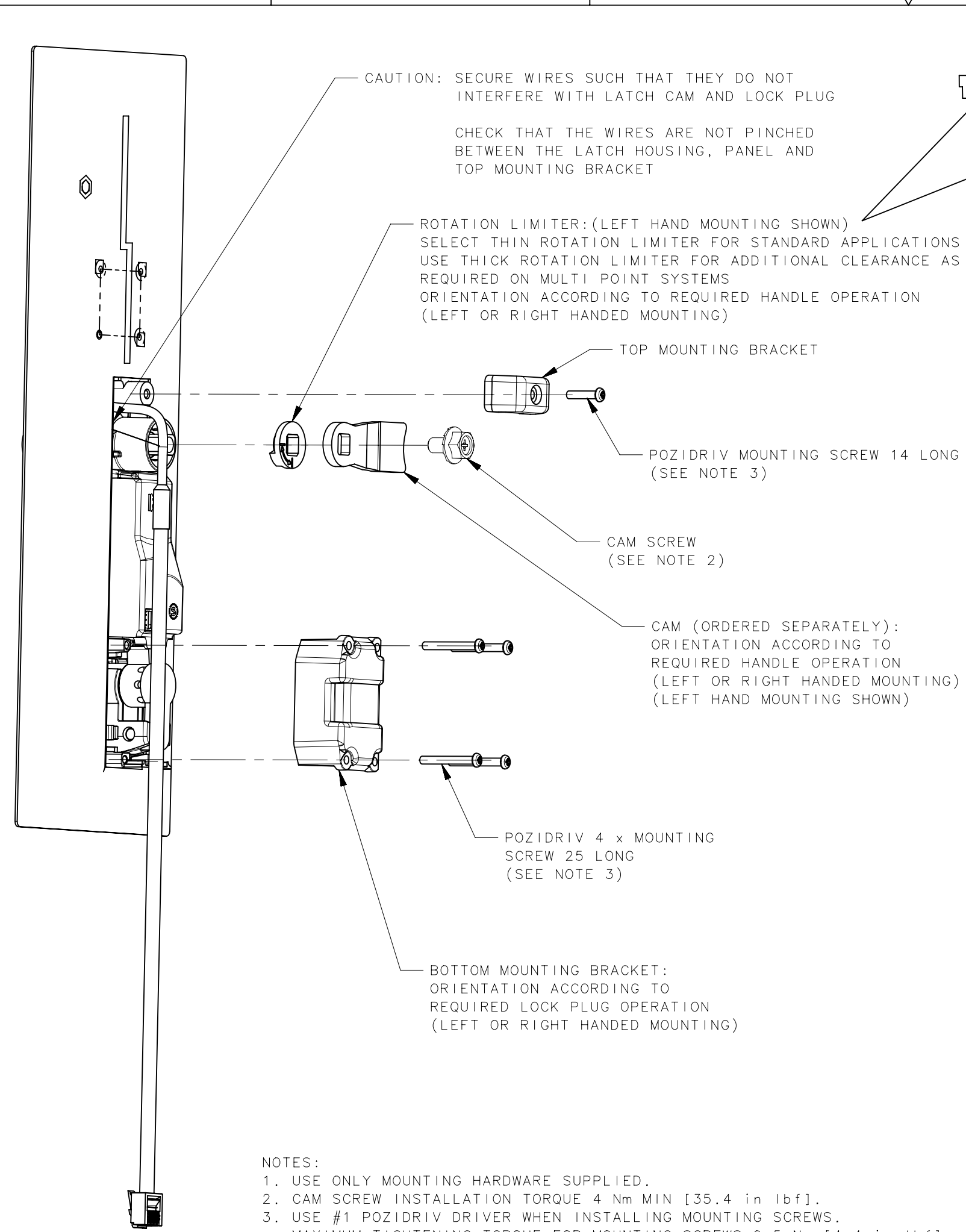

- NOTES:
1. USE ONLY MOUNTING HARDWARE SUPPLIED.
 2. CAM SCREW INSTALLATION TORQUE 4 Nm MIN [35.4 in lbf].
 3. USE #1 POZIDRIV DRIVER WHEN INSTALLING MOUNTING SCREWS.
 MAXIMUM TIGHTENING TORQUE FOR MOUNTING SCREWS 0.5 Nm [4.4 in lbf].

THIRD ANGLE PROJECTION				southco [®] CONNECT · CREATE · INNOVATE		
TOLERANCES UNLESS OTHERWISE NOTED				DESCRIPTION		
ALL DIMENSIONS WITHOUT TOLERANCES ARE FOR REFERENCE ONLY.				H3-EM ELECTRONIC SWINGHANDLE HIGH FREQUENCY		
PROPRIETARY ITEM		SIZE	SYSTEM	DWG NO.		
EXCEPT FOR USES EXPRESSLY GRANTED IN WRITING, INFORMATION DISCLOSED HEREON IS CONFIDENTIAL AND ALL RIGHTS, PATENT AND OTHERWISE, ARE RESERVED BY SOUTHCO, INC.		A3	NX	J-H3-EM-64-1		
PER ASME Y14.5M-1994		DRAWN BY	DATE	SCALE	SHEET	
		DJK	08OCT2014	1:1	2 OF 4	

ACTUATOR MODULE

ELECTRICAL SPECIFICATION:

- A. POWER: 12V TO 24V
 - OPERATING CURRENT: LESS THAN 200mA AT 12VDC WITH NO EXTERNAL MECHANICAL LOAD APPLIED TO HANDLE.
 - MAX CURRENT WITH STALLED ACTUATOR: 1A MAX AT 12VDC (STALL LIMITED TO 2 SECONDS)
 - STANDBY CURRENT: 25mA TYPICAL.
- B. CONTROL INPUT:
 - TO UNLOCK: SUPPLY 9VDC MINIMUM (DO NOT EXCEED SUPPLY VOLTAGE) FOR A MINIMUM OF 100 MILLISECONDS. THE LATCH WILL REMAIN UNLOCKED FOR AS LONG AS THE SIGNAL IS PRESENT OR A MINIMUM OF 3 SECONDS.
- C. OUTPUT:
 - OPEN COLLECTOR OUTPUT. RATING 9 TO 24VDC. 100mA MAX LOAD
 - CAUTION! TO PREVENT DAMAGE TO THE PRODUCT DO NOT EXCEED MAXIMUM LOADS STATED AND FOLLOW WIRING DIRECTIVES.
 - FOR OUTPUT SIGNAL DETAILS AND LED SEQUENCE SEE TRUTH TABLE.
- D. CONNECTIONS:
 - SIX POSITION CONNECTOR
 - HIROSE ELECTRIC CO LTD. PART NUMBER DF11-6DP-2DSA.
 - SEE PIN-OUT TABLE.

PIN	DESCRIPTION	NOTE
1	VGND	GROUND (MUST BE SAME AS RFID READER MODULE)
2	VSUPPLY	12 TO 24 VDC POWER SUPPLY INPUT
3	N/C	NO CONNECT
4	CONTROL SIGNAL	COMMAND INPUT (9VDC UP TO SUPPLY VOLTAGE, 100 MILLISECONDS MINIMUM)
5	ELECTRONIC LOCK STATUS	OPEN COLLECTOR OUTPUT (RATED FOR VSUPPLY, 100mA MAX. LOAD)
6	MECHANICAL LOCK STATUS	OPEN COLLECTOR OUTPUT (RATED FOR VSUPPLY 100mA MAX. LOAD)

- E. WIRE HARNESS (NOT INCLUDED)
 - SOUTHCO P/N: EA-W01-100 *, SEE ALSO J-EA-W01 FROM ACTUATOR MODULE TO STRIPPED AND TINNED END LENGTH 1000MM
 - *CONTACT SOUTHCO FOR OTHER LENGTHS

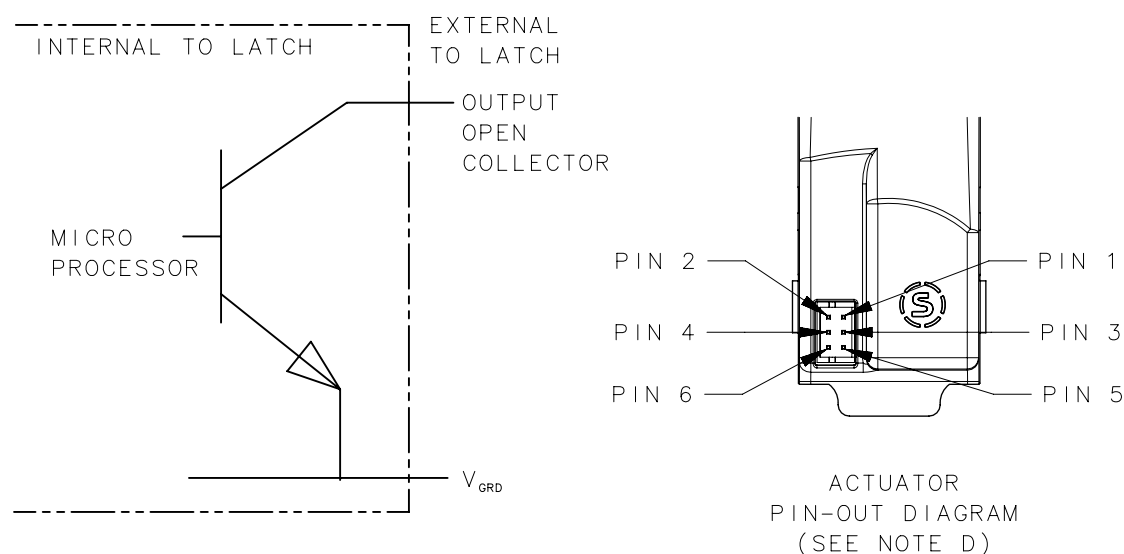

RFID READER MODULE

ELECTRICAL SPECIFICATION:

- F. - SUPPLY VOLTAGE (VCC): 12VDC TO 24VDC
- OPERATING CURRENT: 200mA MAXIMUM (NO EXTERNAL DEVICES ATTACHED)
- TRANSMIT FREQUENCY: 13.56MHz
- DATA SIGNAL VOLTAGE: 5VDC
- DATA PULSE INTERVAL TIME: 40 MICRO-SECONDS (DEFAULT)
- DATA SIGNAL DELAY: 2ms (DEFAULT)
- G. RFID READER CONNECTIONS:
 - 8 POSITIONS MODULAR PLUG
 - SEE PIN-OUT TABLE

PIN-OUT TABLE			
PIN	WIRE COLOR	DESCRIPTION	NOTE
1	WHITE/ORANGE	DATA0	DATA0 OUTPUT
2	ORANGE	DATA1	DATA1 OUTPUT
3	WHITE/GREEN	GREEN LED	GREEN LED INPUT
4	BLUE	HOLD	HOLD INPUT
5	WHITE/BLUE	RED LED	RED LED INPUT
6	GREEN	BUZZER	BUZZER INPUT
7	WHITE/BROWN	VCC	12 TO 24VDC POWER SUPPLY INPUT (MAY BE CONNECTED TO ACTUATOR MODULE V _{SUPPLY} INPUT)
8	BROWN	GROUND	GROUND (MUST BE SAME AS ACTUATOR PORTION)

- H. SEE J-H3-EM-64-100-M ELECTRONIC SWINGHANDLE OPERATING INSTRUCTIONS FOR MORE INFORMATION.

- I. OPERATING TEMPERATURE: 0 TO 45° C

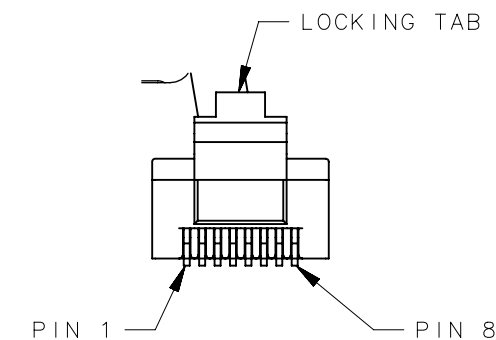

RFID READER
8 POSITIONS MODULAR PLUG
PIN-OUT DIAGRAM
VIEWED FROM MATING CONNECTOR

REVISION HISTORY			
REV	DATE	BY	DESCRIPTION
1	22JUN2023	DPZ/CMS	PRN:P2023-1257

	THIRD ANGLE PROJECTION	<p>CONNECT • CREATE • INNOVATE</p>	
	MILLIMETERS [IN]		
SURFACE AREA	TOLERANCES UNLESS OTHERWISE NOTED	DESCRIPTION H3-EM ELECTRONIC SWINGHANDLE HIGH FREQUENCY	
VOLUME	ALL DIMENSIONS WITHOUT TOLERANCES ARE FOR REFERENCE ONLY.	SIZE A3	SYSTEM NX
PROPRIETARY ITEM	PER ASME Y14.5M-1994	DWG NO. J-H3-EM-64-1	DATE 08OCT2014
EXCEPT FOR USES EXPRESSLY GRANTED IN WRITING, INFORMATION DISCLOSED HEREON IS CONFIDENTIAL AND ALL RIGHTS, PATENT AND OTHERWISE, ARE RESERVED BY SOUTHCO, INC.		DRAWN BY DJK	SCALE 1:1
			SHEET 3 OF 4

REVISION HISTORY			
REV	DATE	BY	DESCRIPTION
1	22JUN2023	DPZ/CMS	PRN:P2023-1257

LATCH STATUS DEFINITION

LATCH STATUS	LATCH LED	PIN 6 OUTPUT HANDLE LOCK	PIN 5 OUTPUT ELECTRONIC LOCK	PIN 4 CONTROL INPUT	NOTE
SECURED	BLUE	OPEN COLLECTOR	OPEN COLLECTOR	GND	ENCLOSURE SECURED- ACCESS DENIED
ELECTRONICALLY RELEASED	BLUE / MAGENTA FLASHING	OPEN COLLECTOR	LOW	V _{ss} ⁺	ENCLOSURE READY FOR ACCESS
MECHANICALLY RELEASED	BLUE FLASHING LOW	LOW	LOW	V _{ss} ⁺	ACCESS GAINED - HANDLE LIFTED OR MECHANICALLY UNLOCKED
		LOW	OPEN COLLECTOR	GND	ACCESS GAINED - HANDLE LIFTED - ELECTRONIC LOCK CLOSED
HANDLE NOT FULLY CLOSED	BLUE / RED FLASHING	OPEN COLLECTOR	LOW	GND	INTERIM STATES ONLY DURING CLOSING OF HANDLE
		LOW	LOW	GND	

ELECTRONIC SWINGHANDLE MATERIALS

COMPONENT	MATERIAL	FINISH	NOTE
H3-EM-64-LLL			
CIRCUIT BOARD	DETAILS ON REQUEST	DETAILS ON REQUEST	
MOTOR	DETAILS ON REQUEST	DETAILS ON REQUEST	
GEAR SHAFT	STAINLESS STEEL	NATURAL	
WORM GEAR	PA66 1300S	NATURAL	
PINION GEAR	POM M90-44	BLACK	
SPUR GEAR	POM M90-44	BLACK	
GEAR RETAINER	PC (LEXAN V0)	CLEAR	
MOTOR COVER	PC ABS (UL94- V0)	BLACK	
LATCH BODY	30% GF NYLON (UL94- V0)	BLACK (A&B SURFACES VD136)	
HANDLE MOULDING	30% GF NYLON (UL94- V0)	BLACK (A&B SURFACES VD136)	
LIGHT PIPE	PC (LEXAN V0)	CLEAR	
BOTTOM MOUNTING BRACKET	30% GF NYLON (UL94- V0)	BLACK	
SLIDE	30% GF NYLON (UL94- V0)	WHITE	
HANDLE SHAFT	DIE CAST ZINC	ZINC PLATE BRIGHT CHROMATE	
ROTATION LIMITER	DIE CAST ZINC	ZINC PLATE BRIGHT CHROMATE	
TOP MOUNTING BRACKET	30% GF NYLON (UL94- V0)	BLACK	
MOUNTING SCREW 25 LONG	STEEL	ZINC PLATE + BRIGHT CHROMATE	INSTALL WITH #1 POZIDRIV DRIVER
MOUNTING SCREW 14 LONG	STEEL	ZINC PLATE + BRIGHT CHROMATE	INSTALL WITH #1 POZIDRIV DRIVER
OUTPUT GEAR MOULDING	POM M90-44	BLACK	
REFLECTOR	POM M90-44	OPAQUE WHITE	
CONNECTING LEAD	DETAILS ON REQUEST	DETAILS ON REQUEST	ORDER SEPARATELY
DIN LOCKPLUG	DETAILS ON REQUEST	DETAILS ON REQUEST	OPTIONAL WITHOUT LOCKPLUG
LOCK PLUG RETAINING SCREW	STEEL	ZINC PLATE + BRIGHT CHROMATE + SEALER	
SHAFT PIN	SAE 30302/30304	PLAIN, OILED	
O-RING	BLACK NBR RUBBER	GREASED	
CAM SCREW	STEEL	ZINC PLATE + BRIGHT CHROMATE	
CAM	STEEL	ZINC PLATE + BRIGHT CHROMATE	ORDER SEPARATELY
RFID READER MODULE	DETAILS ON REQUEST	DETAILS ON REQUEST	
BLANK LOCK PLUG	DIE CAST ZINC	CHROME PLATE	OPTIONAL
SLIDE SPRING	302 STAINLESS STEEL	NATURAL	

SEE SHEET 1,
NOTE 2 FOR FRAME
EDGE DISTANCE.

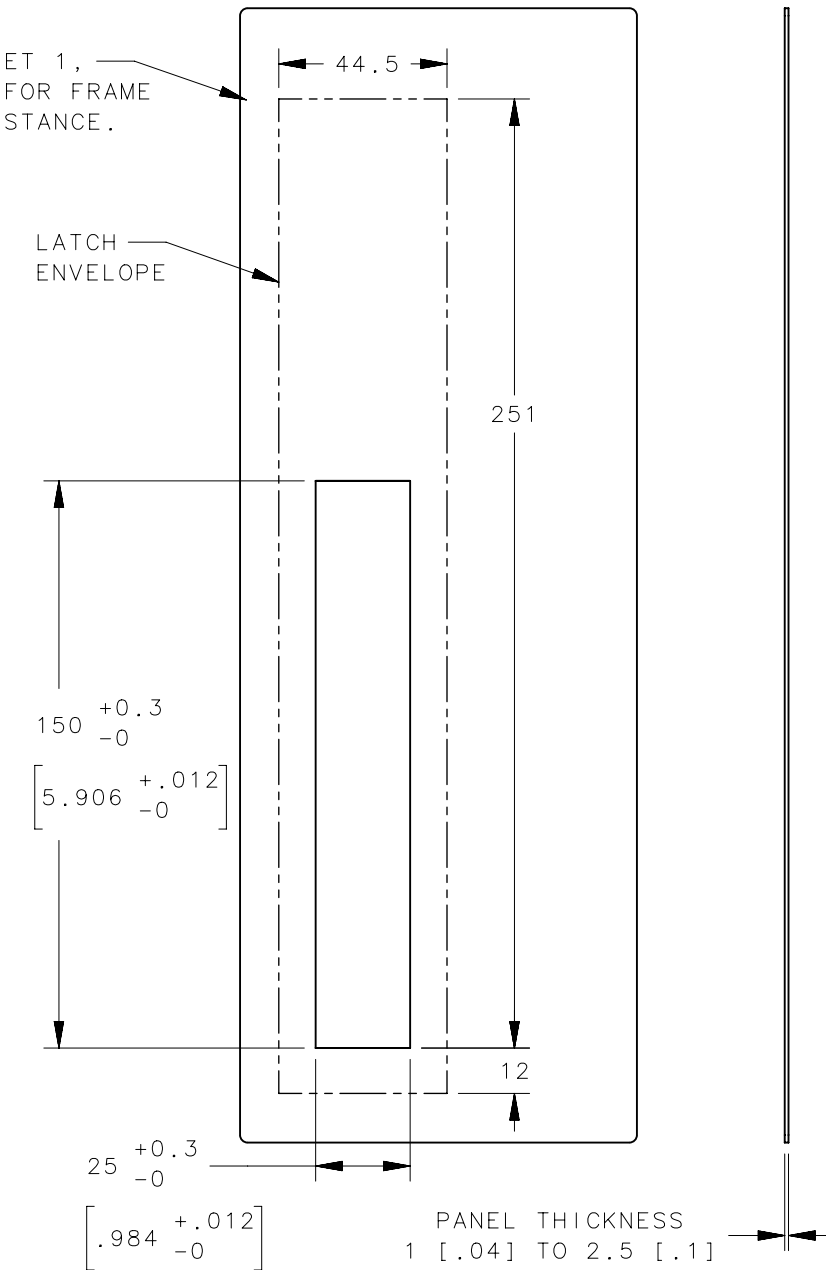

PANEL PREPARATION

NOTE: THER MUST BE 127mm [5"] OF SPACE BETWEEN LATCHES TO OPERATE CORRECTLY

THIRD ANGLE PROJECTION	 CONNECT · CREATE · INNOVATE		
TOLERANCES UNLESS OTHERWISE NOTED	DESCRIPTION H3-EM ELECTRONIC SWINGHANDLE HIGH FREQUENCY		
ALL DIMENSIONS WITHOUT TOLERANCES ARE FOR REFERENCE ONLY.	SIZE A3	SYSTEM NX	DWG NO. J-H3-EM-64-1
PROPRIETARY ITEM <small>EXCEPT FOR USES EXPRESSLY GRANTED IN WRITING, INFORMATION DISCLOSED HEREON IS CONFIDENTIAL AND ALL RIGHTS, PATENT AND OTHERWISE, ARE RESERVED BY SOUTHCO, INC.</small>	PER ASME Y14.5M-1994	DRAWN BY DJK	DATE 08OCT2014
		SCALE 1:1	SHEET 4 OF 4

H3-EM-64 Series Electronic Swinghandle with High Frequency Reader Operating Instructions

Package Contents

- H3-EM-64 Series Electronic Swinghandle with RFID Reader (qty1)
- EM-0-45827 M3x25 POZIDRIV® Mounting Screws (qty 4)
- EM-0-47151 M3x14 POZIDRIV® Mounting Screw (qty 1)
- EM-0-45825 Rotation Limiter (qty 1)
- EM-0-58124 Rotation Limiter (qty 1)
- E5-C-04 Cam Screw (qty 1)
- M3-0-24943-11 Lock Plug Screw (qty 1) (optional)
- EM-0-45826 Top Mounting Bracket (qty 1)
- EM-0-45822 Bottom Mounting Bracket (qty 1)
- Operating Instructions (qty 1)

H3-EM-64 Series Electronic Swinghandle

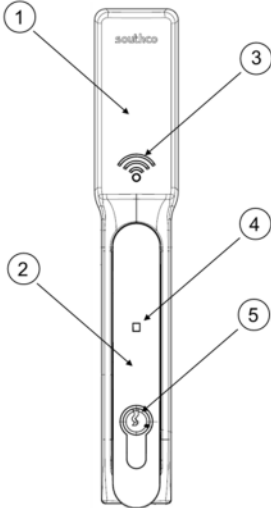

1. RFID Reader
2. Handle
3. RFID Reader Status LED
4. Actuator Status LED
5. Lock Plug (optional)

Features

- Installed 13.56MHz RFID reader module with Wiegand data output
- External control for RFID reader status LED, buzzer and hold functions
- Anti-passback
- Remote lock and unlock capability
- Single or multi-point lock actuation
- Momentary or continuous lock actuation
- Tri-color LED (blue/magenta/red) to indicate lock and handle status
- DIN lock manual override (optional)
- Accommodates both left and right doors
- Custom configurations available
- For indoor use only

⚠ WARNING: The H3-EM-64-000 is shipped without a lockplug. This product must be paired with a Southco-approved lock to function properly. **Use with an unapproved lockplug voids the product warranty.** Contact Southco for additional support.

Specifications

Actuator Module

Supply Voltage (V_{SUPPLY}):	12VDC to 24VDC (NOTE: Status LED will blink red if the supply voltage is out of range.)
Standby Current:	50mA maximum at 12VDC
Operating Current:	200mA maximum at 12VDC (with no external mechanical load applied to handle)
Stall Current:	1A maximum (at 12VDC, limited to 2 seconds)
Operating Transit Time:	1 second maximum (NOTE: Power must be present during transit times. If power is removed while the lock slide is in transit, it will complete it's cycle when power is restored.)
Electronic Unlock Time:	3 seconds minimum
Open Collector Outputs:	Rated for V_{SUPPLY} , 100mA maximum load

RFID Reader Module

Supply Voltage (V_{CC}):	12VDC to 24VDC
Operating Current:	200mA maximum (no external devices attached)
Transmit Frequency:	13.56MHz
DATA Signal Voltage:	5VDC
DATA Pulse Interval Time:	40 μ s (default)
DATA Signal Delay:	2ms (default)

⚠ WARNING: NOT FOR USE WITH PoE

Mounting and Installation

Please refer to Southco trade drawing J-H3-EM-64-1 for mounting and installation details.

⚠ NOTE: Use a #1 POZIDRIV® driver when installing the mounting screws. See Southco trade drawing J-H3-EM-64-1 for additional details.

Wiring Diagrams

The H3-EM-64 Series swinghandle contains two separate functional modules: the actuator module and RFID reader module. The actuator module controls and monitors the locking function of the swinghandle. The RFID module reads the contents of a compatible RFID card and converts it to Wiegand format; it also provides visual and audio feedback to the user thru the status LED and buzzer.

These two modules operate independently of each other and require connection to an access control unit (**not provided**), as illustrated below, for the entire product to be fully functional.

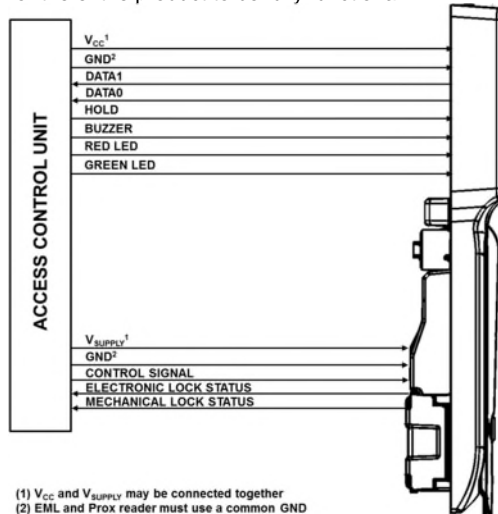

(1) V_{CC} and V_{SUPPLY} may be connected together
(2) EML and Prox reader must use a common GND

H3-EM-64 Series Electronic Swinghandle with High Frequency Reader Operating Instructions

The actuator module of the swinghandle is accessed with a six-position connector on the rear of the unit, shown below.

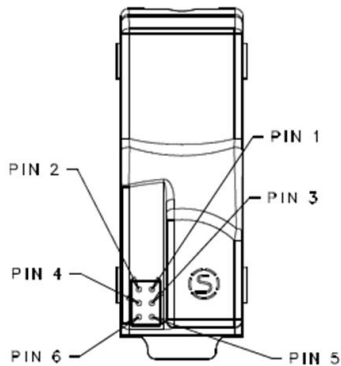

⚠ NOTE: The mating connectors/harnesses are not provided with the swinghandle. Refer to Southco trade drawing J-H3-EM-64-1 for mating connector/harness requirements.

In addition, a configuration connector is located on the rear of the RFID module. **This is for factory configuration only, and not for customer use.**

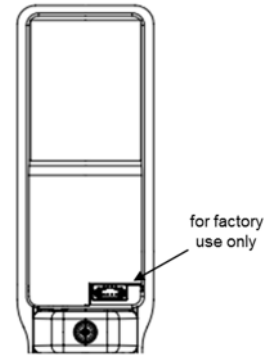

Pin	Description	Note
1	V _{GND}	ground (must be same as RFID reader module)
2	V _{SUPPLY}	12 to 24 VDC power supply input (may be connected to RFID reader V _{CC} input)
3	N/C	no connect
4	Control Signal	command input (9VDC up to supply voltage, 100 milliseconds minimum)
5	Electronic Lock Status	open collector output (rated for V _{SUPPLY} , 100mA max. load)
6	Mechanical Lock Status	open collector output (rated for V _{SUPPLY} , 100mA max. load)

Compatible Card Types

The H3-EM-64 Series is compatible with multiple card types. Please refer to the *Default Compatible Cards* section for a list of cards that can be read by the H3-EM-64 by default.

Contact Southco if additional card types are required.

Wiegand DATA Output

Data is transmitted from the RFID module on the DATA1 and DATA0 lines.

Default pulse interval and signal delay times are 40µs and 2ms, respectively.

Please refer to the *Default Compatible Cards* section for the card content and reader output

RFID Reader Status LED

The default setting for the status LED without connection to a controller is:

event	LED color
power-on	"off"
card read	green
idle	red

⚠ NOTE: The status LED will be "off" at power-on. It will remain "off" until either a compatible card is presented to the reader or the HOLD input is asserted LO.

An external access control system is able to control the LED color by driving the GREEN LED and RED LED inputs LO. If both signals are asserted, the LED will be green.

Anti-Passback

The RFID reader has an anti-passback feature. This requires a card to be removed from the reader's RF field before the next card is read. If a card remains in the RF field after being read, the status LED will flash red. If this occurs, move the card away from the reader until the status LED turns solid red, then present the next card.

The RFID reader module of the swinghandle is accessed with an eight-position RJ45 connector attached to a harness connected to the module's circuit board. The module's connector pinout is:

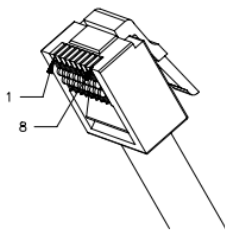

Pin	Description	Note
1	DATA0	DATA0 output.
2	DATA1	DATA1 output
3	GREEN LED	Active LO signal. Used to turn RFID status LED green.
4	HOLD	Active LO input signal. When asserted in RFID module's default state, will hold card read function until de-asserted.
5	RED LED	Active LO signal. Used to turn RFID status LED red.
6	BUZZER	Active LO input signal. When asserted in RFID module's default state, will sound buzzer until de-asserted.
7	V _{VCC}	12 to 24 VDC power supply input (may be connected to actuator module V _{SUPPLY} input)
8	V _{GND}	ground (must be same as actuator module)

HOLD Input

When asserted LO in the default state, the HOLD input will prevent a card from being read by the reader. When released, the card contents will be read and transmitted on the DATA1 and DATA0 outputs.

BUZZER Input

When asserted LO in the default state, the BUZZER input will sound the buzzer. The buzzer will sound for as long as the signal is asserted.

Control Input Signal

This signal is used to control the electronic lock slide position.

- for UNLOCKED position: Assert control signal (9VDC up to supply voltage) for at least 100 milliseconds. The lock will remain unlocked for as long as the signal is present, or a minimum of 3 seconds. Signal timing can typically be adjusted at the access control device. The control signal current draw is less than 10mA.
- for LOCKED position: Supply an open contact or 0VDC (0 to 0.5V)

Electronic Lock Status Output and Mechanical Lock Status Output Signals

Electronic Lock Status Output Signal

This output will be LOW (GND) when the lock slide is electromechanically moved to the unlocked position. It will be in the open collector state (high-impedance) when in the locked position.

Mechanical Lock Status Output Signal

This output will be LOW (GND) when the handle is in the open position or when the keylock in the actuator is manually unlocked. It will be in the open collector state (high-impedance) when in the secured position.

⚠ NOTE: These outputs are open collector outputs rated for V_{SUPPLY} with a maximum load of 100mA. To avoid damage to the H3-EM, do not exceed voltage and current ratings.

Status LED and Output Signals

The latch is equipped with a tri-color (blue/magenta/red) LED visible from the front of the latch. This LED provides a visible notification of the latch status. The different latch states are described below. Please refer to the **Control Input Signal**, **Electronic Lock Status Output Signal**, and **Mechanical Lock Status Output Signal** sections for further details on these signals.

Secured

The latch is securely closed, prohibiting access.

- The Status LED will be solid blue.
- The electronic lock status output is at its open collector state.
- The mechanical lock status output is at its open collector state.

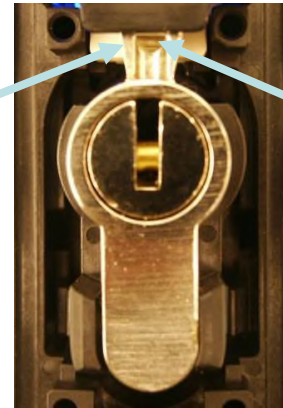

handle secured in housing, cam in locked position

electronic lock slide in locked position

"Secured" State

Electronically Released

The electronic lock slide is in the unlocked position and the handle can be pulled open.

- The Status LED will alternate flashing blue/magenta.
- The electronic lock status output is 0V while the lock slide is in the unlocked position.
- The mechanical lock status output is at its open collector state.



handle secured in housing, cam in locked position

electronic lock slide in unlocked position

"Electronically Released" State

Mechanically Released

The latch is released by opening the handle or moving the cam from its lock position.

- The Status LED will flash blue.
- The electronic lock status output will be at its open collector state if the electronic lock slide is in the locked position. It will be 0V if the lock slide is in the unlocked position.
- The mechanical lock status output is 0V.

⚠ NOTE: The lock sensor is an optical device that senses the presence of the lock pawl. Reflectivity of the lock pawl material can affect sensing. Use only Southco-supplied locks.

H3-EM-64 Series Electronic Swinghandle with High Frequency Reader Operating Instructions

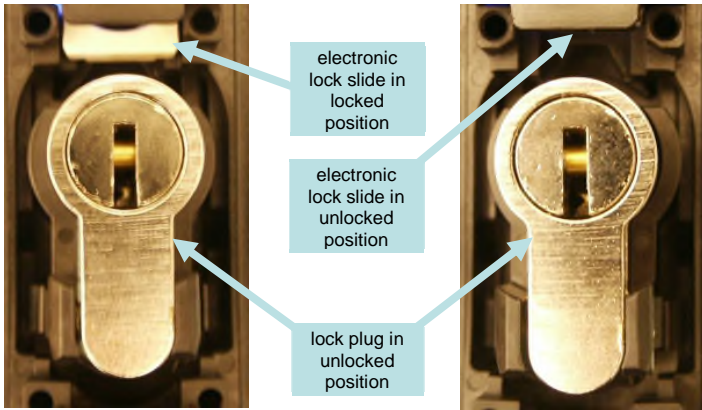

"Mechanically Released" State

Handle not Fully Closed

This is an interim state and may occur while closing the handle when the cam is not secured by the electronic lock slide. The latch is not fully secured during this state.

- The Status LED will alternate flashing blue/red if the cam is not detected. It will flash blue/red/red if the cam is detected, but the lock plate is not in the right position. This could be due to mechanical failure or tampering.
- The electronic lock status output is 0V if the lock slide is in the unlocked position. It will be at its open collector state if it is in the lock position.
- The mechanical lock status output is 0V if the cam is not detected. It will be at its open collector state if it is detected.

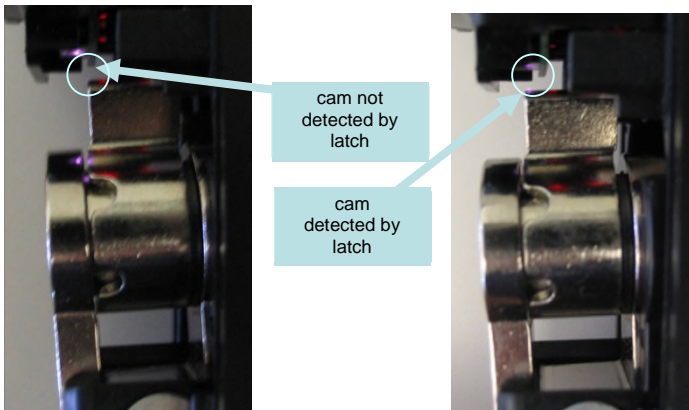

"Handle not Fully Closed" State

Electronic Lock Slide Error

The electronic lock slide does not respond to the command input signal.

- The Status LED will flash magenta if the latch is secured. It will alternate flashing red/magenta if the latch is mechanically released.
- The electronic lock status output is at its open collector state.
- The mechanical lock status output will be at its open collector state if the cam is in its lock position. It will be 0V if the mechanical key is moved from its lock position.

Error Input Command Sequence

The H3-EM can accept an input command from an external controller to flash the status LED red three times. This feature can be used to indicate that an error event has occurred (e.g. unauthorized access attempt).

The control input signal needs to meet the timing requirements shown below to flash the status LED red.

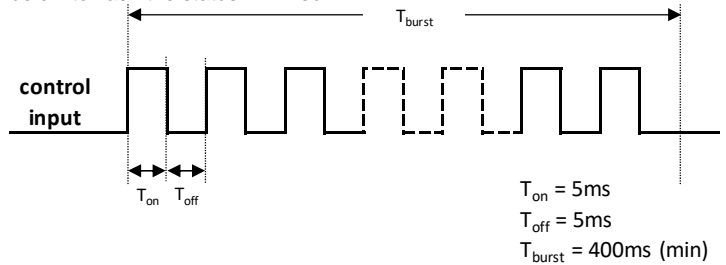

Default Compatible Cards

The H3-EM-64 Series swinghandle is compatible with the following card types by default. Contact Southco if additional card types are required.

card type	Southco part number	output content	output format (includes upper/lower parity)
iCLASS	n/a	PACS	reverse byte order
MIFARE Classic 4k HID MIFARE	n/a	UID	reverse byte order
iCLASS SE	n/a	PACS	reverse byte order
MIFARE Classic 4k SE	n/a	PACS	reverse byte order
iCLASS SR	n/a	PACS	reverse byte order
MIFARE DESFire EV1 SE	n/a	PACS	reverse byte order
iCLASS SEOS	n/a	PACS	reverse byte order
MIFARE Ultralight	n/a	UID	reverse byte order
MIFARE DESFire 4k	n/a	UID	reverse byte order
MIFARE Plus 2k	n/a	UID	reverse byte order

FCC Compliance Statement

This device complies with Part 15 of the FCC Rules. Operation is subject to the following two conditions: (1) This device may not cause harmful interference, and (2) this device must accept any interference received, including interference that may cause undesired operation.

This equipment has been tested and found to comply with the limits for a Class B digital device, pursuant to part 15 of the FCC Rules. These limits are designed to provide reasonable protection against harmful interference when the equipment is operated in a commercial environment. This equipment generates, uses, and can radiate radio frequency energy and, if not installed and used in accordance with the instruction manual, may cause harmful interference to radio communications. Operation of this equipment in a residential area is likely to cause harmful interference in which case the user will be required to correct the interference at his own expense.

Industry Canada Compliance Statement

This device complies with Industry Canada licence-exempt RSS standard(s). Operation is subject to the following two conditions: (1) this device may not cause interference, and (2) this device must accept any interference, including interference that may cause undesired operation of the device.

Le présent appareil est conforme aux CNR d'Industrie Canada applicables aux appareils radio exempts de licence. L'exploitation est autorisée aux deux conditions suivantes: (1) l'appareil ne doit pas produire de brouillage, et (2) l'utilisateur de l'appareil doit accepter tout brouillage radioélectrique subi, même si le brouillage est susceptible d'en compromettre le fonctionnement.



POZIDRIV® is a registered trademark of the Phillips Screw Company

MIFARE and MIFARE Classic are trademarks of NXP B.V.

HID® and iCLASS® are registered trademarks of HID Global (patented, www.hidglobal.com/patents)