



No. 3 LINK LOCK KICKOUT SPRING

DATE	DRAWN	CHKD	SCALE	DRAWING NUMBER
12SEP96	SWD		1 : 1	J-K3-1887

REV.	DATE	BY-CHKD	REVISIONS	PART NUMBER	MATERIAL	FINISH
				K3-1887-07	SEE NOTE A	SEE NOTE A
				K3-1887-52	SEE NOTE B	SEE NOTE B

NOTE A: ANCHOR PLATE, HOUSING, WING, UPPER CAM, LOWER CAM, AND ANCHOR PLATE RIVET ARE CARBON STEEL; ZINC PLATE, BRIGHT CROMATE DIP. SLIDE IS HARDENED ALLOY STEEL; ZINC PLATE, BRIGHT CROMATE DIP. CAP, CAM RIVET AND KICKOUT SPRING ARE STAINLESS STEEL.

NOTE B: ALL COMPONENTS ARE STAINLESS STEEL, NATURAL FINISH.

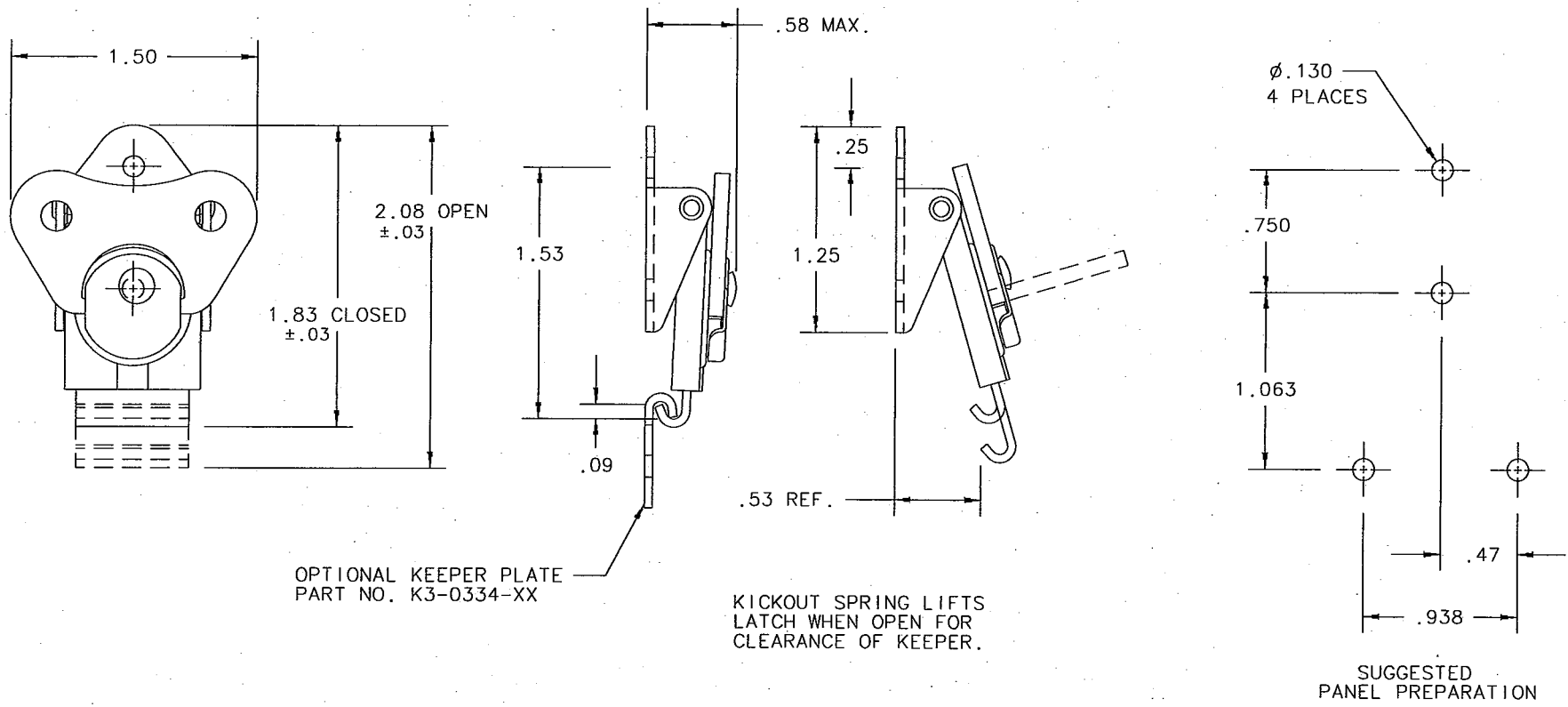

FORMAT 1 MAR 94

PROPRIETARY ITEM - EXCEPT FOR USES EXPRESSLY GRANTED IN WRITING INFORMATION DISCLOSED HEREON IS CONFIDENTIAL AND ALL RIGHTS PATENT AND OTHERWISE ARE RESERVED BY SOUTHCO, INC.

DIMENSIONS ARE IN INCHES

DRAWING NUMBER
J-K3-1887