

NOTES :

A. MATERIAL AND FINISH:

SHANK AND SPINDLE- TYPE 17-4 PH STAINLESS STEEL PER AMS 5643 OR EQUIVALENT, PASSIVATED PER ASTM A967
 HANDLE- CAST ALUMINUM ALLOY PER ASTM B85 OR 6061-T6 EXTRUDED ALUMINUM PER AMS-QQ-A-A200/8, BLACK ANODIZE PER AMS-A-8625.
 BUTTON- TYPE 303 STAINLESS STEEL PER ASTM A581/582, PASSIVATED PER ASTM A967 OR 2024 ALUMINUM ALLOY PER AMS QQ-A-225/6, BLACK ANODIZE PER AMS-A-8625.
 BALLS- 440C STAINLESS STEEL PER AMS-QQ-S-763, PASSIVATED PER ASTM A967.
 WASHER- TYPE 300 SERIES STAINLESS STEEL PER ASTM A240, PASSIVATED PER ASTM A967.
 SPRING- TYPE 302 STAINLESS STEEL PER ASTM A313, PASSIVATED PER ASTM A967.
 ATTACHING RING- 302 STAINLESS STEEL PER ASTM A313 PASSIVATED PER ASTM A967 OR HARD DRAWN CARBON STEEL WIRE PER ASTM A227.
 LANYARD- STAINLESS STEEL CABLE PER MIL-DTL-83420, TYPE 1, COMP. B WITH VINYL COATING PER MIL-I-631, TYPE F, GRADE A, CAT. 1, COLOR GREEN.

B. SOUTHCO IS A QSLM CERTIFIED MANUFACTURER OF QUICK RELEASE PINS. THE LOCKWELL QUICK RELEASE PINS ON THIS DRAWING CAN BE MANUFACTURED TO THE SPECIFICATIONS OF MS17985 AND NAS1333 THRU NAS1346. PARTS ORDERED TO MS AND NAS SPECIFICATIONS ARE CERTIFIED TO NAS1332 AND NASM23460.

C. WHEN MANUFACTURED TO MS OR NAS SPECIFICATIONS, MS OR NAS IS PUNCHED IN THIS LOCATION.

southco

PROPRIETARY ITEM - EXCEPT FOR USES EXPRESSLY GRANTED IN WRITING INFORMATION DISCLOSED HEREON IS CONFIDENTIAL AND ALL RIGHTS PATENT AND OTHERWISE ARE RESERVED BY SOUTHCO, INC.

ASSEMBLY, LOCKWELL PIN, "T" HANDLE SINGLE ACTING

DATE	DRAWN	CHKD	SCALE	DRAWING NUMBER
23JAN2009	MJS	JF	1.25:1	J-LG-CT
				INCHES
				ALL DIMENSIONS WITHOUT TOLERANCES ARE FOR REFERENCE ONLY.
THIRD ANGLE PROJECTION		B PAPER SIZE		CAGE CODE SV287

REV	DATE	DRAWN/CHKD	DESCRIPTION
A	23JAN2009	MJS/JF	INITIAL RELEASE

PART NUMBER:
 LG-D C T G F 750 L12

SHANK DIA (SEE TABLE)

GRIP IN THOUSANDTH INCH INCREMENTS
 EX: LG-4CT1000L6 = 0.25 in. DIAMETER, 1 in. GRIP LENGTH, 2-BALL, 6 in. LANYARD

LANYARD LENGTH IN INCHES
 (OMIT IF NO LANYARD REQUIRED)

LONGER NON-STD "R" DIM IN THOUSANDTH INCH INCREMENTS. (OMIT FOR STD. "R" DIM)

"F" = 4 BALL
 (OMIT FOR STANDARD LENGTH 2 BALL)

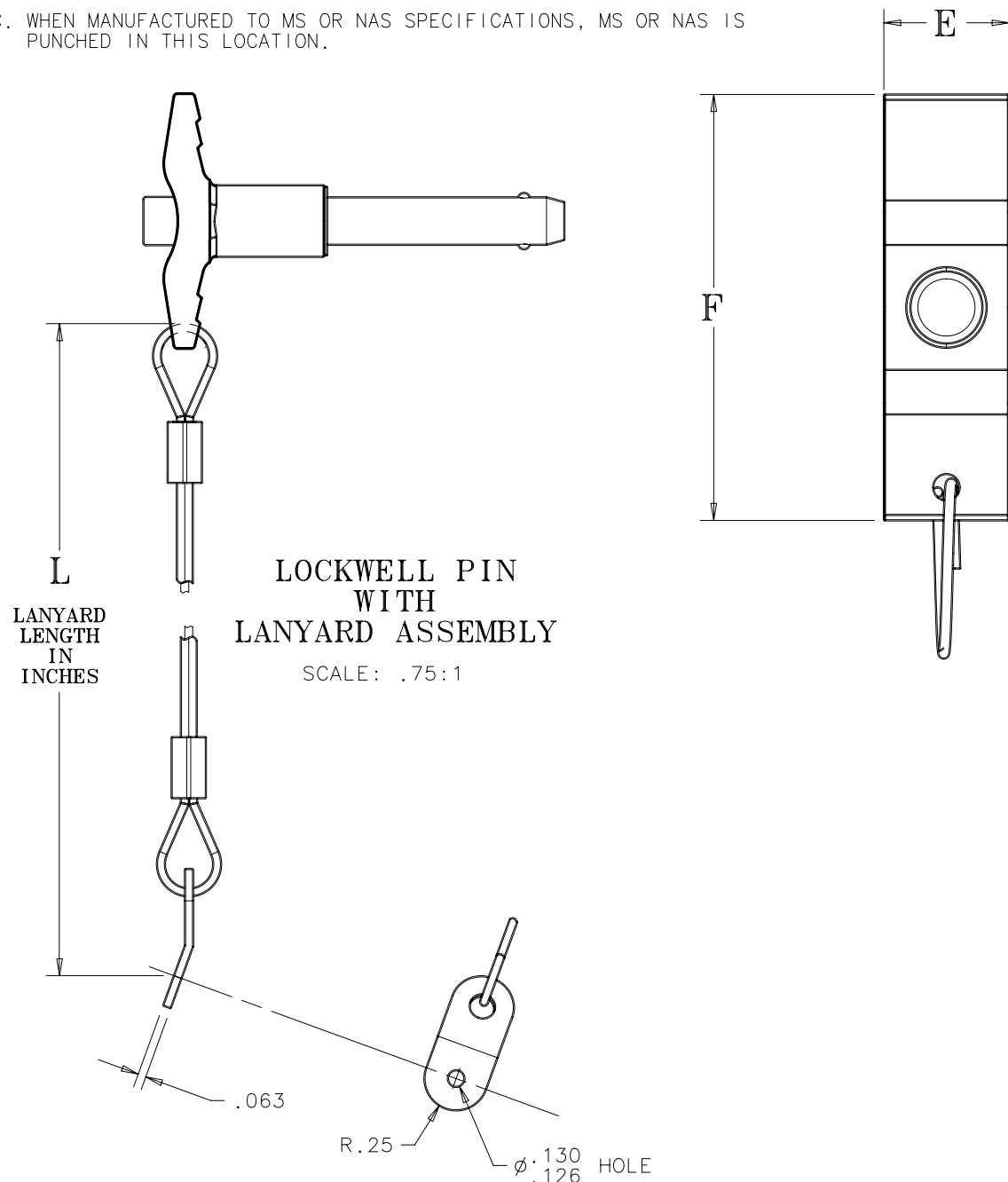

LOCKWELL PIN WITH LANYARD ASSEMBLY
 SCALE: .75:1

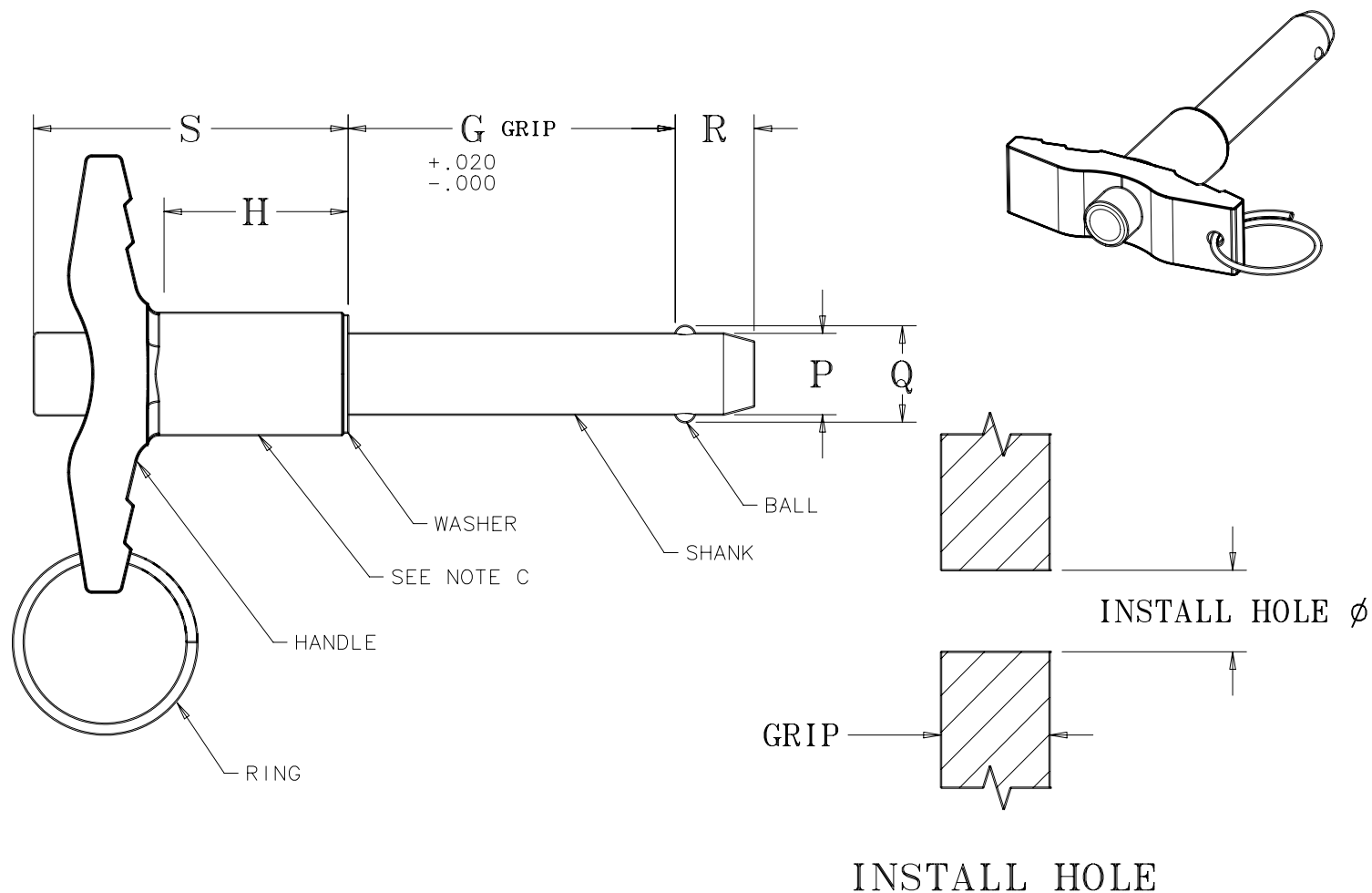

PIN SIZE	D	ØP +.0000 -.0015	Q ±.005	R +.000 -.030	E	F	S MAX.	H MIN.	MIN. TENSION LOAD CAPABILITIES		CALCULATED DOUBLE SHEAR STRENGTH	INSTALL HOLE Ø	
									2-BALL	4-BALL		MIN.	MAX.
3/16	3	.1885	.220	.260	.500/.380	1.815/1.750	1.270	.800	200 lbf	260 lbf	5150 lbf	.190	.194
1/4	4	.2485	.289	.290	.500/.380	1.815/1.750	1.270	.800	230 lbf	290 lbf	9200 lbf	.250	.254
5/16	5	.3110	.375	.330	.500/.380	1.815/1.750	1.270	.800	510 lbf	630 lbf	14400 lbf	.3125	.3165
3/8	6	.3735	.440	.365	.625/.510	2.000/1.935	1.450	.850	575 lbf	740 lbf	20600 lbf	.375	.379
7/16	7	.4360	.509	.380	.625/.510	2.065/2.000	1.470	.850	710 lbf	920 lbf	28000 lbf	.4375	.4425
1/2	8	.4985	.594	.460	.800/.630	2.345/2.250	1.600	.885	1160 lbf	1500 lbf	36800 lbf	.500	.505
9/16	9	.5610	.666	.510	.800/.630	2.345/2.250	1.600	.885	1420 lbf	1840 lbf	46000 lbf	.5625	.5675
5/8	10	.6235	.750	.580	.975/.810	3.000/2.250	1.700	.980	2070 lbf	2690 lbf	57500 lbf	.625	.630
3/4	12	.7485	.887	.670	1.000/.810	3.000/2.250	1.720	1.030	2950 lbf	3835 lbf	82500 lbf	.750	.757
7/8	14	.8735	1.046	.760	1.320/1.120	3.000/2.750	2.140	1.310	3900 lbf	5070 lbf	112500 lbf	.875	.882
1	16	.9985	1.219	.890	1.320/1.180	3.000/2.750	2.140	1.310	5480 lbf	7120 lbf	147000 lbf	1.000	1.010