

REVISION HISTORY			
REV	DATE	BY	DESCRIPTION
A	25SEP2017	NBK/DMS	PRN: P2017-2367

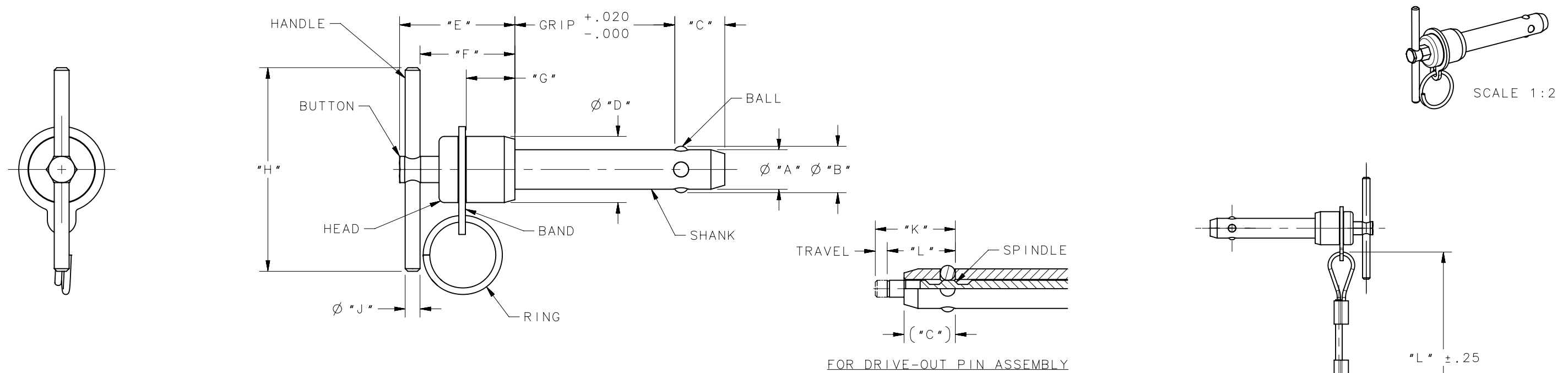

NOTES:

- A. PART NUMBER INFO:
- |  |   |
|--|---|
| LH - 4 C T 1500 D E 750 L 12 - MS      |   |
| LOCKWELL DOUBLE ACTING PIN             | MS = PINS SUPPLIED AS MEETING MS STANDARDS  |
| SHANK DIA IN 1/16THS (1/4 DIA)         | NAS = PINS SUPPLIED AS MEETING NAS STANDARDS  |
| MATERIAL                               | LANYARD LENGTH IN INCHES  |
| "T" BAR HANDLE STYLE                   | "L" EXTENSION AND SUFFIX FOR LANYARD REQUIREMENT. OMIT THIS SUFFIX IF NO LANYARD IS REQUIRED            |
| GRIP LENGTH IN THOUSAND INCH INCREMENT | LONGER NON-STANDARD "C" DIM IN THOUSANDTHS INCH INCREMENTS ( OMIT FOR STANDARD TABULATED "C" DIMENSION. |
| DRIVE OUT                              | "F" = FOUR BALL PIN   |
| D = DRIVE OUT                          | OMIT FOR TWO BALL PIN   |
| OMIT FOR STANDARD                      |   |
| NON DRIVE CONSTRUCTION                 |   |

B. MATERIAL AND FINISH: ALL COMPONENTS STAINLESS STEEL, PASSIVATED; CABLE-STAINLESS STEEL, VINYL COATED(GREEN)

PIN DASH No.	A +.0000 -.0015	B	C +.000 -.050	Ø D	E MAX	F MIN	G	H	Ø J MIN	K MAX	L MAX
3	.1885	.225/.215	.410	.450/.360	1.030	.780	.480/.415	1.750/1.375	.105	.64	.50
4	.2485	.292/.284	.410	.450/.360	1.030	.780	.480/.415	1.750/1.375	.105	.64	.50
5	.3110	.377/.370	.440	.505/.445	1.030	.780	.480/.415	1.750/1.375	.105	.68	.55
6	.3735	.443/.435	.510	.630/.510	1.090	.830	.540/.445	2.000/1.875	.134	.79	.64
7	.4360	.512/.504	.510	.630/.510	1.090	.830	.540/.445	2.000/1.875	.134	.79	.64
8	.4985	.598/.589	.590	.755/.640	1.270	.880	.540/.445	2.250/2.125	.200	.92	.75
9	.5610	.671/.661	.660	.755/.640	1.270	.880	.540/.445	2.250/2.125	.200	1.02	.82
10	.6235	.753/.745	.750	.870/.805	1.465	1.000	.575/.510	2.500/2.375	.231	1.15	.93
12	.7485	.892/.882	.790	.960/.890	1.465	1.000	.595/.530	2.500/2.375	.231	1.19	.97
14	.8735	1.048/1.041	.950	1.150/1.070	1.640	1.180	.730/.665	2.875/2.750	.231	1.44	1.18
16	.9985	1.222/1.214	1.100	1.280/1.200	1.830	1.320	.865/.800	2.875/2.750	.231	1.65	1.35

THIRD ANGLE PROJECTION				
SURFACE AREA	TOLERANCES UNLESS OTHERWISE NOTED		DESCRIPTION	
VOLUME	ALL DIMENSIONS WITHOUT TOLERANCES ARE FOR REFERENCE ONLY.		LH QUICK RELEASE PIN "T" HANDLE DOUBLE ACTING	
PROPRIETARY ITEM	SIZE	SYSTEM	DWG NO.	
EXCEPT FOR USES EXPRESSLY GRANTED IN WRITING, INFORMATION DISCLOSED HEREON IS CONFIDENTIAL AND ALL RIGHTS, PATENT AND OTHERWISE, ARE RESERVED BY SOUTHCO, INC.	B	NX	J-LH-T	
PER ASME Y14.5M-1994	DRAWN BY	DATE	SCALE	SHEET
	NBK/DMS	23SEP2017	1:1	1 OF 1