

METRIC DIMENSIONS

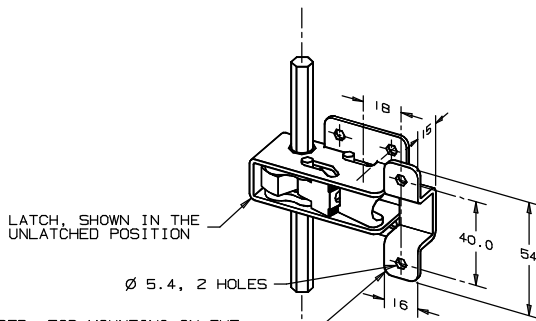

OPTIONAL KEEPER, FOR MOUNTING ON THE FRONT SURFACE OF THE CABINET OR FRAME. GRIP RANGE, FROM LATCH MOUNTING SURFACE TO KEEPER MOUNTING SURFACE: 15 MIN. TO 30 MAX.

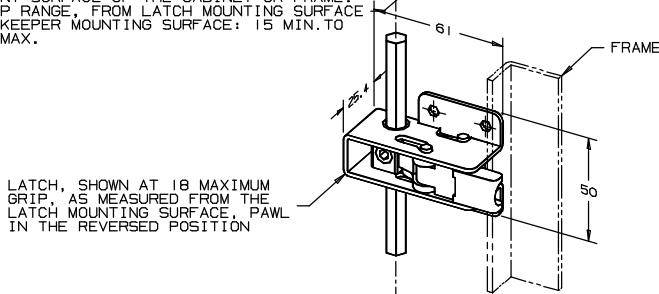

LATCH, SHOWN AT 18 MAXIMUM GRIP, AS MEASURED FROM THE LATCH MOUNTING SURFACE, PAWL IN THE REVERSED POSITION

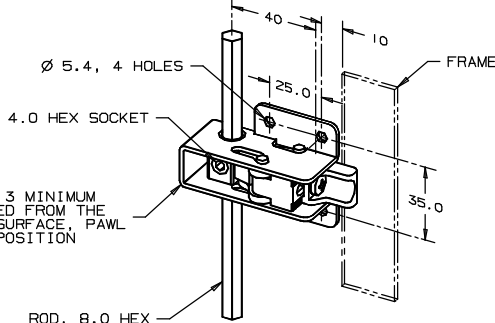

LATCH, SHOWN AT 3 MINIMUM GRIP, AS MEASURED FROM THE LATCH MOUNTING SURFACE, PAWL IN THE FORWARD POSITION

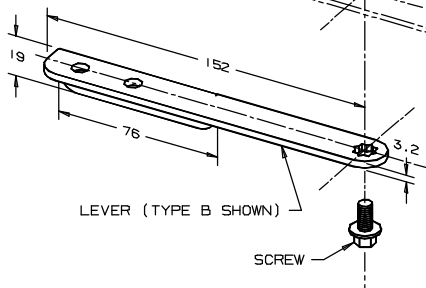
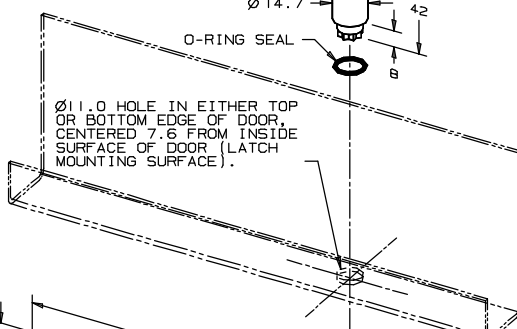
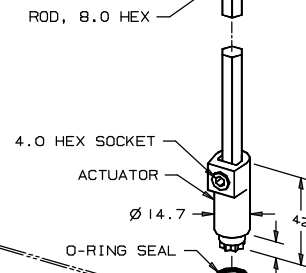

PART NUMBERS

LEVER, TYPE B (USED ON LOWER LEFT HAND CORNER OF TYPE B DOORS OR UPPER RIGHT HAND CORNER OF TYPE A DOORS), INCLUDING ACTUATOR, O-RING SEAL AND SCREW: M3-32.

LATCH: M3-50

KEEPER: M3-51

ROD: M3-XXX, WHERE XXX IS THE TOTAL LENGTH IN CENTIMETERS. MINIMUM ROD LENGTH = DISTANCE FROM THE EDGE OF THE DOOR TO THE CENTERLINE OF THE MOST REMOTE LATCH.

NOTE: RODS ARE MANUFACTURED TO SPECIAL SPECIFICATIONS STEELS NOT SUPPLIED BY SOUTHCO SHOULD BE STAINLESS STEEL OR STEEL AND SHOULD HAVE NO MORE THAN 1° TWIST IN ANY 1 METER LENGTH.

SPECIFICATIONS

25 MM INWARD CLEARANCE REQUIRED FOR THE LATCH. (31 WHEN LATCH IS ADJUSTED TO MAXIMUM GRIP). 11 INWARD CLEARANCE REQUIRED FOR THE ACTUATOR, AS MEASURED FROM ITS CENTERLINE.

THE ROD WILL BOW ENOUGH TO ALLOW THE HOLE IN THE EDGE OF THE DOOR TO BE MOVED INWARD BY AS MUCH AS 2.5, PROVIDED THE DISTANCE FROM THE EDGE OF THE DOOR TO THE NEAREST LATCH IS NOT LESS THAN 20 CM.

THE LATCH HAS AN OVER-CENTER TOGGLE ACTION WITH APPROXIMATELY 5.1 MM OF PAWL PULL-UP TO THE FULLY LATCHED POSITION. (DURING LATCHING, THE PAWL PULLS UP 6.4 MM AND DROPS BACK 1.3 MM)

PULL-UP FORCE PER LATCH SHOULD NOT EXCEED 445 NEWTONS. TO DETERMINE THE MINIMUM NUMBER OF LATCHES WHICH MUST BE USED, DIVIDE THE TOTAL REQUIRED PULL-UP FORCE IN NEWTONS BY 445.

INSTALLATION INSTRUCTIONS

ATTACH THE LATCHES TO THE DOOR. WITH THE LATCHES IN THE LATCHED POSITION, SLIDE THE ROD THROUGH ALL OF THE ROD ASSEMBLIES. INSTALL THE ACTUATOR ON THE END OF THE ROD AND TIGHTEN THE SETSCREW TO 4.5 TO 6.8 NEWTON-METERS TORQUE. SLIDE THE ROD TOWARDS THE EDGE OF THE DOOR, SEATING THE O-RING SEAL, AND TIGHTEN THE SETSCREWS IN THE LATCHES TO 4.5 TO 6.8 NEWTON-METERS TORQUE. ATTACH THE LEVER TO THE END OF THE ACTUATOR. ADJUST THE LATCHES FOR THE PROPER GRIP (PAWL ADJUSTS TO 0.8 INCREMENTS) AND TIGHTEN THE PAWL SCREWS SECURELY.

MATERIAL AND FINISH

THE LEVER ASSEMBLY CONSISTS OF LEVER, 1008/1010 STEEL, BLACK POWDER COATED; ACTUATOR, DIE CAST ZINC, CHEMICAL PROTECTIVE FILM; SETSCREW, STEEL, ZINC PLATED, YELLOW, WITH NYLON PATCH; O-RING SEAL, BUNA N, NATURAL; AND SCREW, STEEL, BLACK FLUOROPOLYMER.

THE LATCH CONSISTS OF CRANK, PAWL SUPPORTS AND PAWL, DIE CAST ZINC, CHEMICAL PROTECTIVE FILM; HOUSING AND LINKS, 1008/1010 STEEL, ZINC PLATED, BRIGHT; BUSHINGS, STEEL, ZINC PLATED, BRIGHT; LONG PIN, LOW CARBON STEEL, NICKEL PLATED; SHORT PIN, LOW CARBON STEEL, ZINC PLATED; SCREW, LOCKWASHER AND NUT, STEEL, ZINC PLATED, YELLOW; AND SETSCREW, STEEL, ZINC PLATED, YELLOW, WITH NYLON PATCH.

THE KEEPER IS 1008/1010 STEEL, ZINC PLATED, YELLOW.

THE ROD IS TYPE 303 STAINLESS STEEL, NATURAL.

TOLERANCES

ZERO PLACE: ±1 ONE PLACE: ±0.1