

REV.	DATE	DRAWN	BY	DESCRIPTION	REVISION	PART NUMBER	DIN LOCK	PLUG	PADLOCK	OPTION
H	28DEC2002	AJH/VN	JRN	P2002-0882		M3-40-110-25	NO			SUPPLIED BY SOUTHCO
I	10FEB2004	AJH/RLR	JRN	P2004-0134		M3-40-111-25	YES			SUPPLIED BY SOUTHCO
						M3-40-120-25	NO			NOT SUPPLIED
						M3-40-121-25	YES			NOT SUPPLIED

ALL DIMENSIONS ARE IN MILLIMETERS.  
ALL DIMENSIONS WITHOUT TOLERANCES ARE REFERENCE.

A3 PAPER SIZE  
THIRD ANGLE PROJECTION

INSTALLATION INSTRUCTIONS:

INSERT LIFT HANDLE ACTUATOR INTO PANEL CUTOUT, POSITION BRACKET ON OPPOSITE SIDE OF PANEL AND FASTEN TO LIFT HANDLE ACTUATOR USING MOUNTING SCREWS. TIGHTEN MOUNTING SCREWS WITH DRIVER SET TO 3.4 N-m MIN. - 4.5 N-m MAX. TORQUE. INSERT CRANK INTO SLIDE. WITH REMOTE LATCHES (NOT SHOWN) IN THE CLOSED POSITION, INSERT ROD THROUGH REMOTE LATCHES AND CRANK.

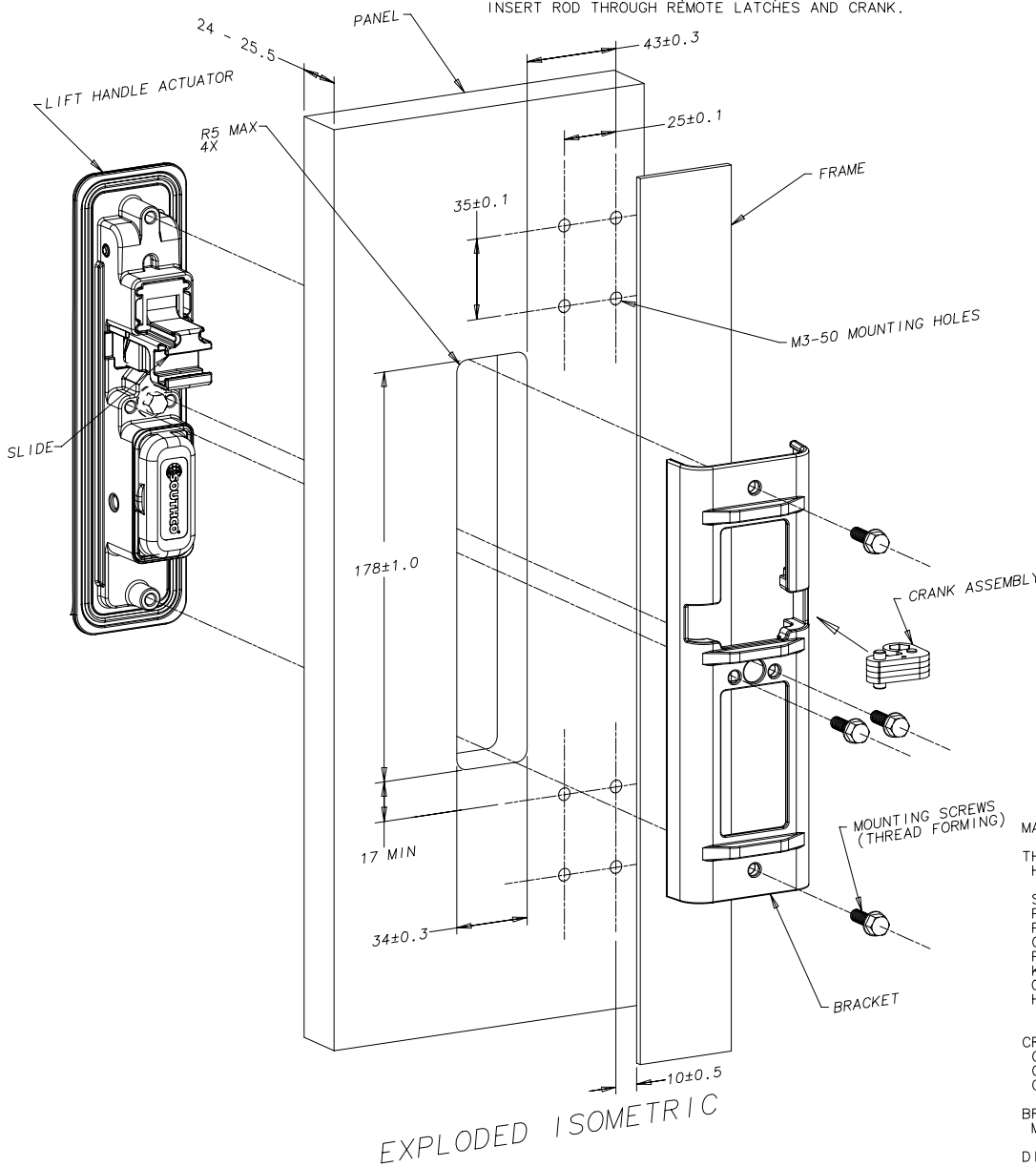

EXPLODED ISOMETRIC

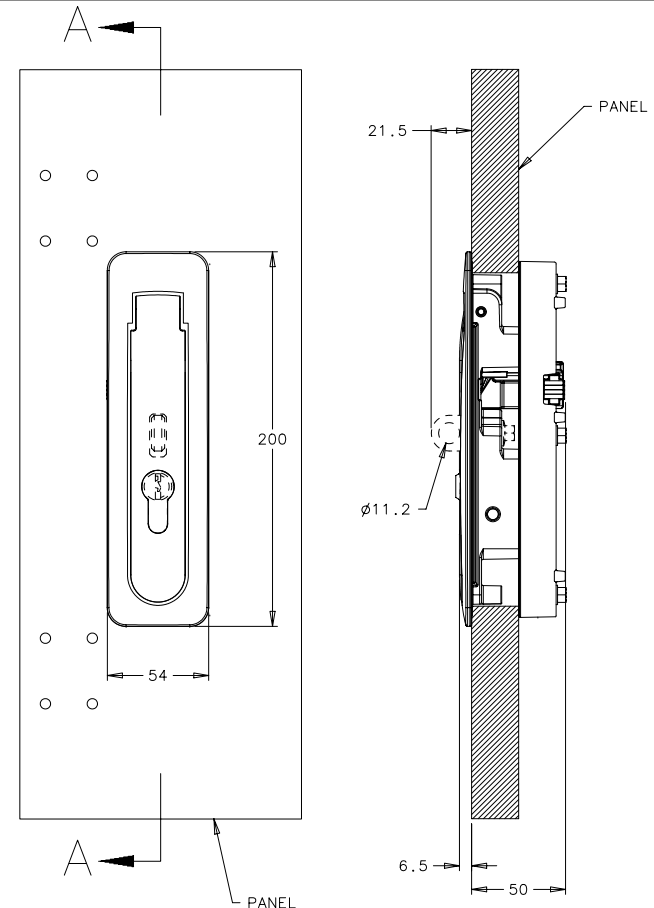

SECTION A-A  
PANEL SECTIONED ONLY

INSTALLED VIEWS

MATERIAL AND FINISH: SCALE: .38:1

THE LIFT HANDLE ACTUATOR CONSISTS OF:  
HOUSING, HANDLE, COVER PLATE, - DIE CAST ZINC, BLACK POWDER COATED, WITH SILICONE AND URETHANE GASKETS

SLIDE - DIE CAST ZINC, ORGANIC COATING  
PIVOT PIN OUTER SHELL - 303 STAINLESS STEEL, PASSIVATED  
PIVOT PIN INNER SHELL - 303 STAINLESS STEEL, PASSIVATED  
CAGE - POLYETHER IMIDE, BLACK  
PIVOT PIN SPRING - 302 STAINLESS STEEL, NATURAL  
KICK OUT SPRING - 301 STAINLESS STEEL, PASSIVATED  
O-RINGS - EPDM, BLACK  
HASP - 316 STAINLESS STEEL, RESIN IMPREGNATED  
HASP MOUNTING SCREW - STEEL, ZINC PLATE BRIGHT

CRANK ASSEMBLY  
CRANK LAMINATE - 304 STAINLESS STEEL, PASSIVATED  
CRANK PIN - 300 STAINLESS STEEL, PASSIVATED  
CRANK RIVET - STAINLESS STEEL, PASSIVATED

BRACKET - DIE CAST ZINC, BLACK POWDER COAT  
MOUNTING SCREWS - STEEL, ZINC PLATE BRIGHT

DIN LOCK PLUG - BODY - BRASS WITH DULL NICKEL PLATING