

REVISION HISTORY			
REV	DATE	BY	DESCRIPTION
A	13SEP2012	CMS/RES	PRN: P2012-1234

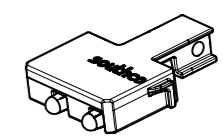

ROUND STYLE LIGHT PIPE
SCALE 1:1

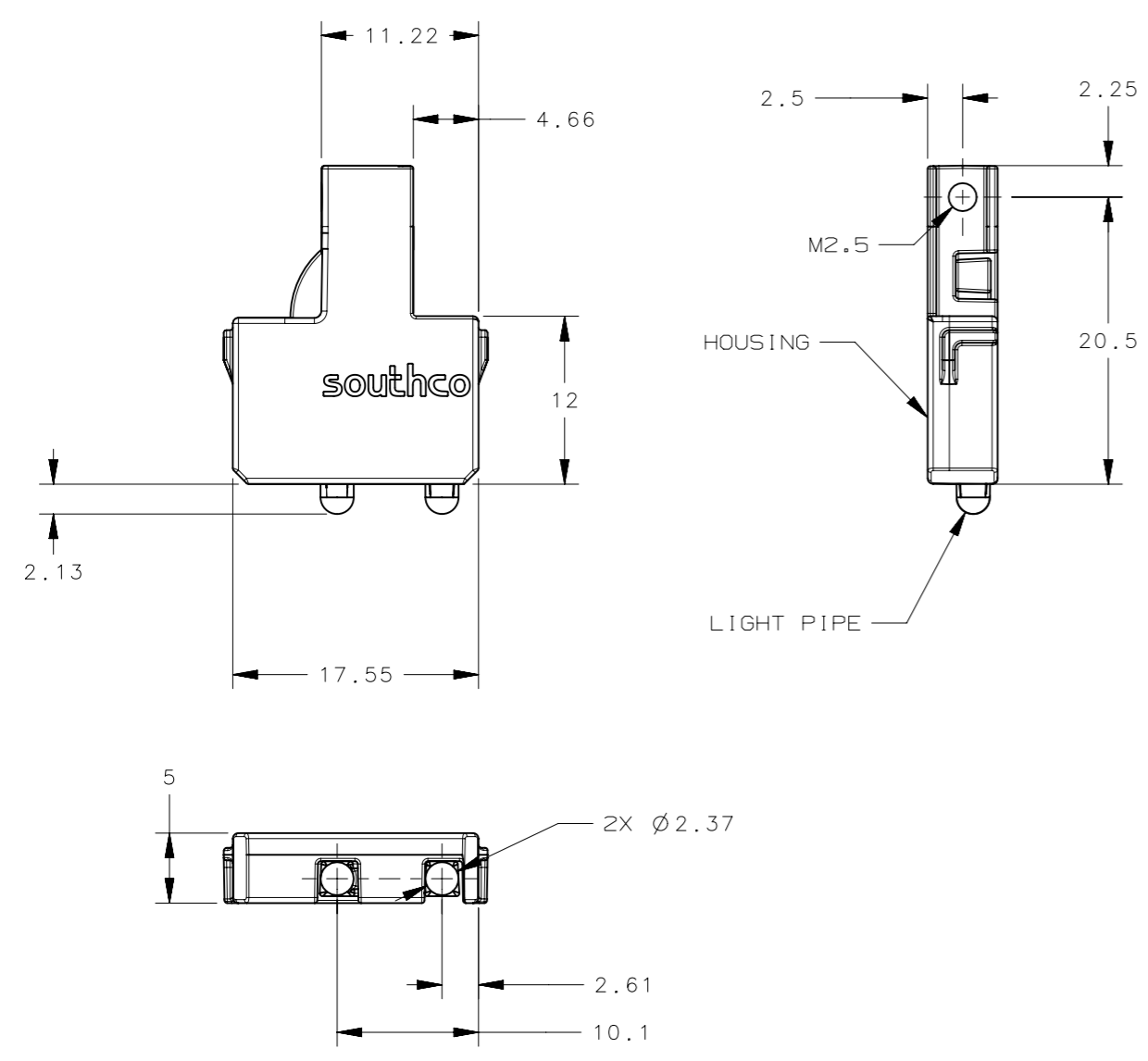

- NOTES:
- A. MATERIAL AND FINISH:
HOUSING - DIE CAST ZINC, CLEAR CHROMATE
LIGHT PIPE - POLYCARBONATE, CLEAR, UL94-V0
 - B. THIS ASSEMBLY IS RoHS COMPLIANT
 - C. HOUSING TO MEET CLASS C REQUIREMENTS;
LIGHT PIPE TO MEET CLASS A REQUIREMENTS OF
SOUTHCO COSMETIC SPECIFICATION S-121
 - D. MEETS REQUIREMENTS OF PICMG AMC.0 R2.0
SPECIFICATION

P7-L-812		LIGHT PIPE ASSEMBLY		ROUND	
PART NUMBER		TYPE OF COMPONENT		LIGHT PIPE STYLE	
THIRD ANGLE PROJECTION		MILLIMETERS [IN]		 CONNECT • CREATE • INNOVATE	
SURFACE AREA XXXXXmm ²		TOLERANCES UNLESS OTHERWISE NOTED			
VOLUME XXXXXmm ³		ALL DIMENSIONS WITHOUT TOLERANCES ARE FOR REFERENCE ONLY.		DESCRIPTION Inject/Eject Mechanism AMC MIDSIZE MODULE LIGHT PIPE ASSEMBLY	
PROPRIETARY ITEM		PER ASME Y14.5M-1994		SIZE A3	SYSTEM NX
EXCEPT FOR USES EXPRESSLY GRANTED IN WRITING, INFORMATION DISCLOSED HEREON IS CONFIDENTIAL AND ALL RIGHTS, PATENT AND OTHERWISE, ARE RESERVED BY SOUTHCO, INC.		DRAWN BY RES		DATE 13SEP2012	DWG NO. J-P7-L-812
				SCALE 2:1	SHEET 1 OF 2

REVISION HISTORY			
REV	DATE	BY	DESCRIPTION
A	13SEP2012	CMS/RES	PRN: P2012-1234

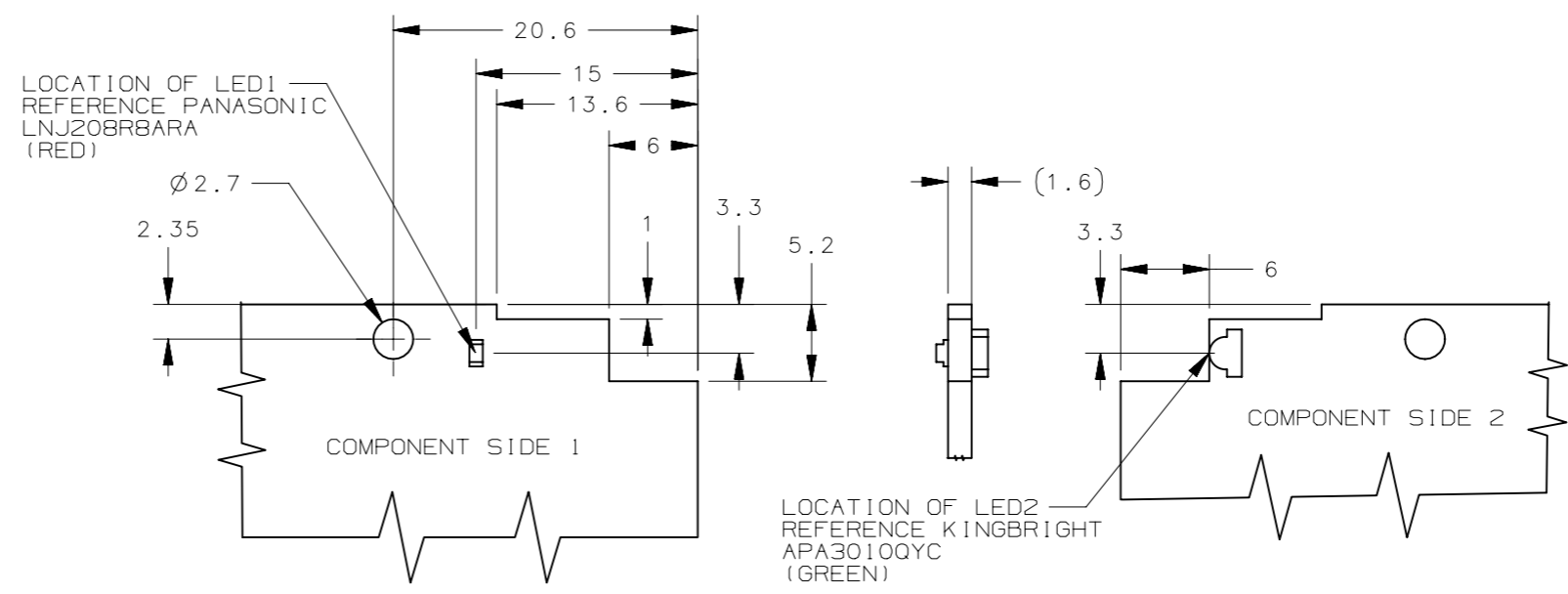

- INSTALLATION:
1. SNAP HOUSING INTO FACE PLATE
 2. ATTACH PCB USING M2.5 SCREW (NOT SUPPLIED)

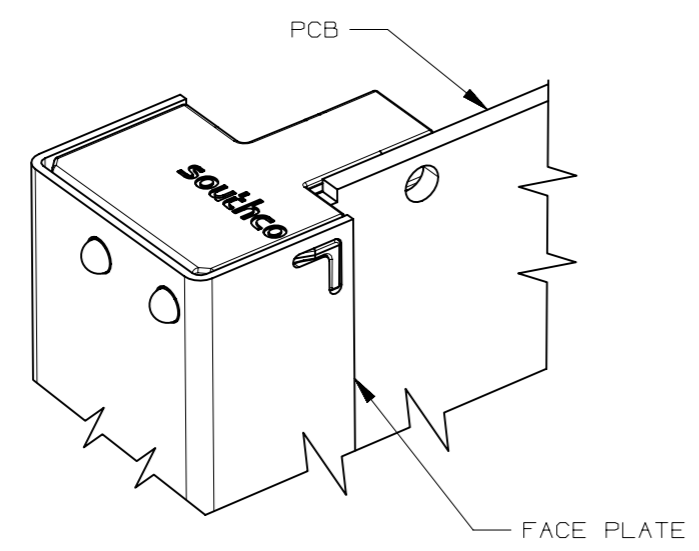

ALL PANEL PREPARATION TOLERANCES
TO BE ± 0.1

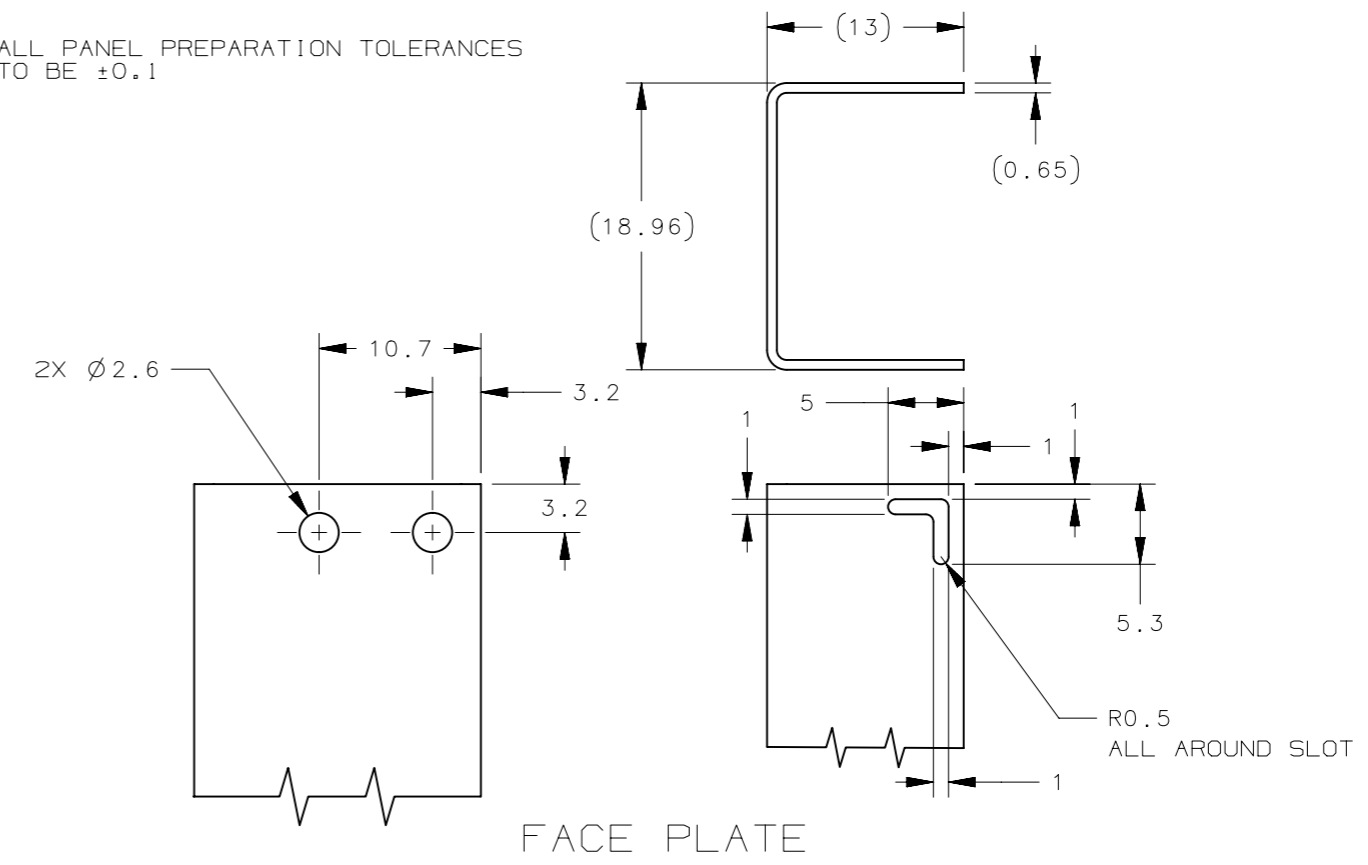

THIRD ANGLE PROJECTION				southco [®] CONNECT • CREATE • INNOVATE	
MILLIMETERS [IN]					
TOLERANCES UNLESS OTHERWISE NOTED		DESCRIPTION			
SURFACE AREA XXXXXmm ²		Inject/Eject Mechanism			
VOLUME XXXXXmm ³		AMC MIDSIZE MODULE LIGHT PIPE ASSEMBLY			
PROPRIETARY ITEM		SIZE A3	SYSTEM NX	DWG NO. J-P7-11-812	
EXCEPT FOR USES EXPRESSLY GRANTED IN WRITING, INFORMATION DISCLOSED HEREON IS CONFIDENTIAL AND ALL RIGHTS, PATENT AND OTHERWISE, ARE RESERVED BY SOUTHCO, INC.		PER ASME Y14.5M-1994		DRAWN BY RES	DATE 13SEP2012
		SCALE 2:1	SHEET 2 OF 2		