

REVISION HISTORY			
REV	DATE	BY	DESCRIPTION
B	21DEC2023	SBK/VK	PRN:P2023-2365

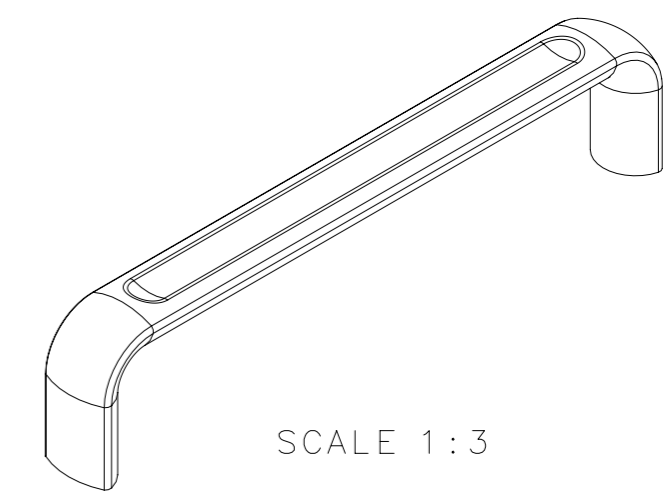

PANEL PREPARATION

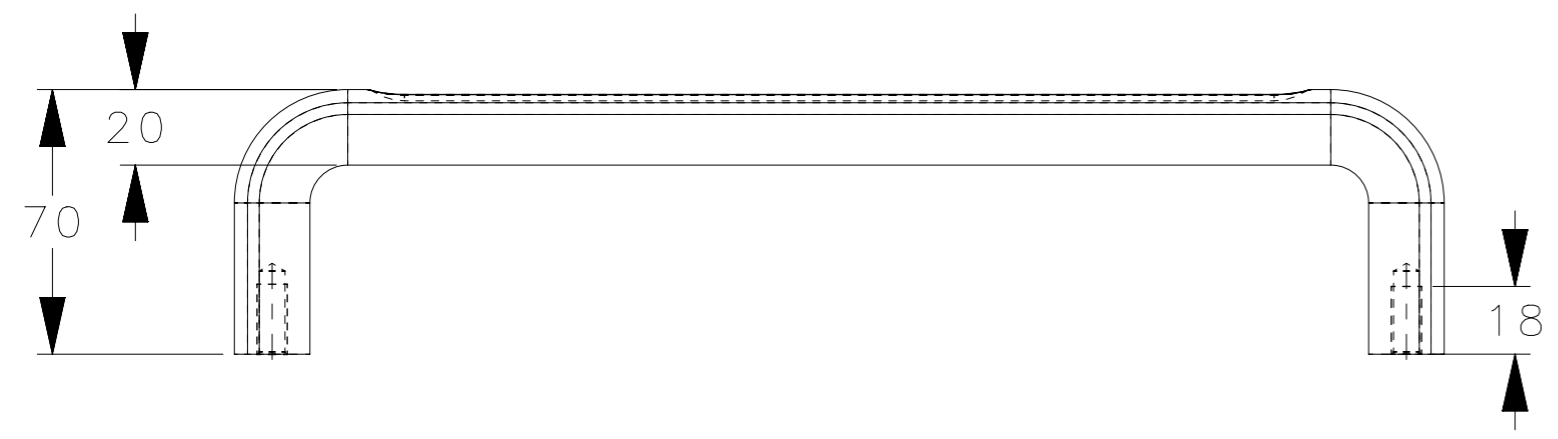
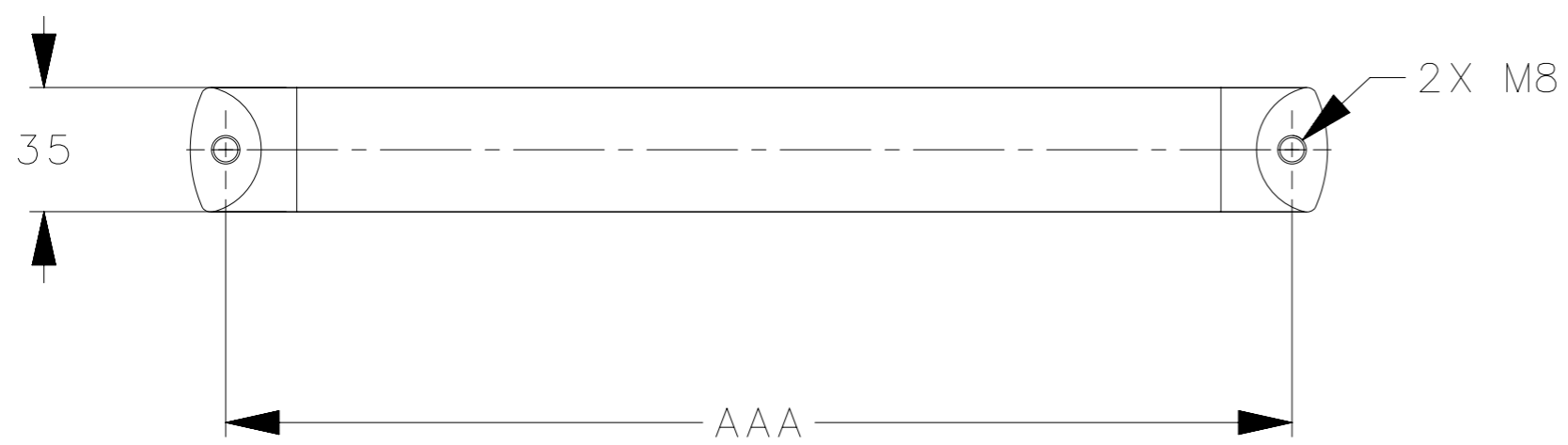
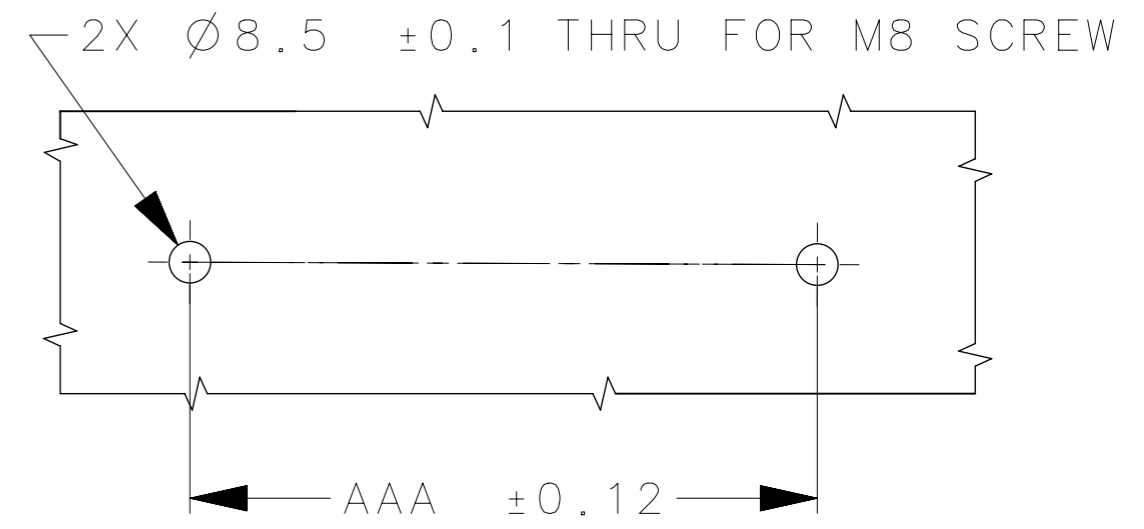

P8-DHAE-3-600-PC	P8 -LARGE PULL HANDLE	ALUMINUM	BALCK POWDER COATING	600
P8-DHAE-3-500-PC	P8 -LARGE PULL HANDLE	ALUMINUM	BALCK POWDER COATING	500
P8-DHAE-3-400-PC	P8 -LARGE PULL HANDLE	ALUMINUM	BALCK POWDER COATING	400
P8-DHAE-3-300-PC	P8 -LARGE PULL HANDLE	ALUMINUM	BALCK POWDER COATING	300
P8-DHAE-3-250-PC	P8 -LARGE PULL HANDLE	ALUMINUM	BALCK POWDER COATING	250
P8-DHAE-3-600-SPC	P8 -LARGE PULL HANDLE	ALUMINUM	SILVER SPARKLE POWDER COATING	600
P8-DHAE-3-500-SPC	P8 -LARGE PULL HANDLE	ALUMINUM	SILVER SPARKLE POWDER COATING	500
P8-DHAE-3-400-SPC	P8 -LARGE PULL HANDLE	ALUMINUM	SILVER SPARKLE POWDER COATING	400
P8-DHAE-3-300-SPC	P8 -LARGE PULL HANDLE	ALUMINUM	SILVER SPARKLE POWDER COATING	300
SOUTHCO PART NUMBER	DESCRIPTION	MATERIAL	FINISH	LENGTH (AAA)

CPB NUMBER 2023-0391	THIRD ANGLE PROJECTION			
	MILLIMETERS [IN]			
SURFACE AREA mm ²	TOLERANCES UNLESS OTHERWISE NOTED	DESCRIPTION P8 -LARGE PULL HANDLE		
VOLUME mm ³	ALL DIMENSIONS WITHOUT TOLERANCES ARE FOR REFERENCE ONLY.	SIZE A3	SYSTEM NX	DWG NO. J-P8-DHAE-3
PROPRIETARY ITEM EXCEPT FOR USES EXPRESSLY GRANTED IN WRITING, INFORMATION DISCLOSED HEREON IS CONFIDENTIAL AND ALL RIGHTS, PATENT AND OTHERWISE, ARE RESERVED BY SOUTHCO, INC.	PER ASME Y14.5M-2009	DRAWN BY SBK/VK	DATE 05JUL2023	SCALE 1:1
			SHEET 1 OF 1	

NOTES:-
 1. MOUNTING SCREWS NOT SUPPLIED.
 2. FOR e.g AAA=300 THE REAL LENGTH IS 300.