

REVISION HISTORY			
REV	DATE	BY	DESCRIPTION
H	15MAR2018	CBI/DMS	PRN: P2018-0655

PART NUMBER: R4-81-SL1-PP-KC

- S = LATCH STAGE AND BUMPER OPTIONS
 2= SINGLE STAGE
 4= TWO STAGE
 6= SINGLE STAGE WITH INTEGRATED BUMPER
 8= TWO STAGE WITH INTEGRATED BUMPER

- L = LOCKING OPTIONS
 1 - REVERSIBLE KEY (R001), NO KEYS INCLUDED
 2 - REVERSIBLE KEY (R001), 2 KEYS INCLUDED
 3 - REVERSIBLE KEY (MULTIPLE KEYCODES), 2 KEYS INCLUDED
 4 - STANDARD KEY (CH751), NO KEYS INCLUDED
 5 - STANDARD KEY (CH751), 2 KEYS INCLUDED
 6 - STANDARD KEY (MULTIPLE KEYCODES), 2 KEYS INCLUDED
 9 - NO LOCKPLUG INSTALLED

- PP = PADDLE FINISH OPTIONS
 30 - POLISHED CHROME PADDLE
 50 - BLACK POWDER COAT PADDLE

- KC = KEY CODE OPTIONS
 KD10 - KEYED DIFFERENTLY, 10 CODES (ONLY USED IF L= 3 OR 6)
 MK10 - MASTER KEYED, KEYED DIFFERENTLY, 10 CODES (ONLY USED IF L= 6)

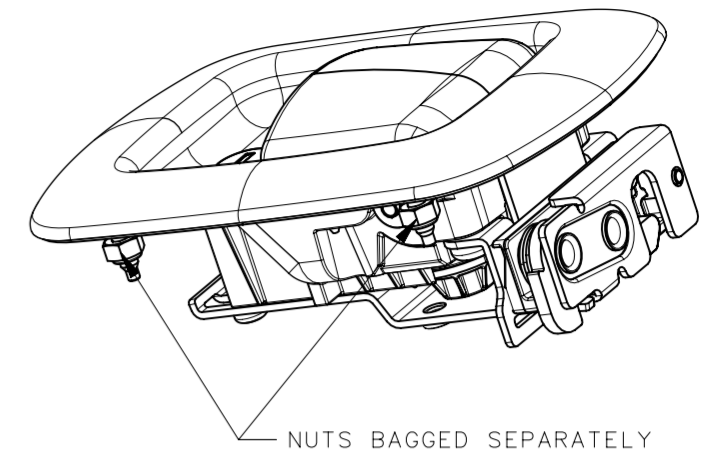
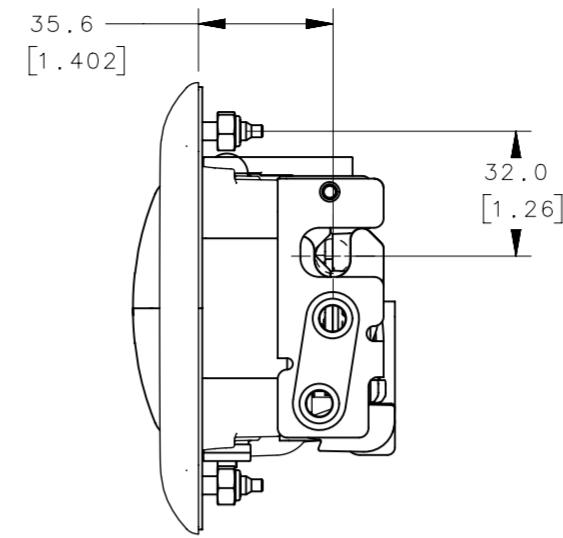
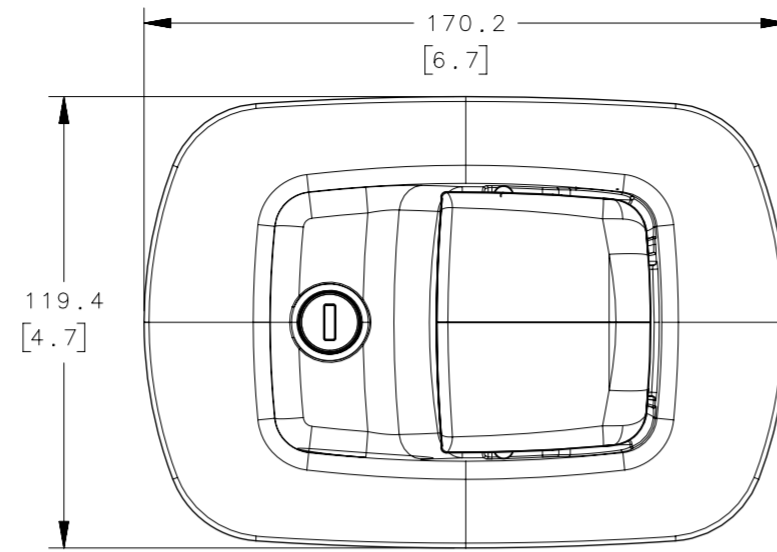

LATCH WITH INTEGRATED BUMPER OPTION

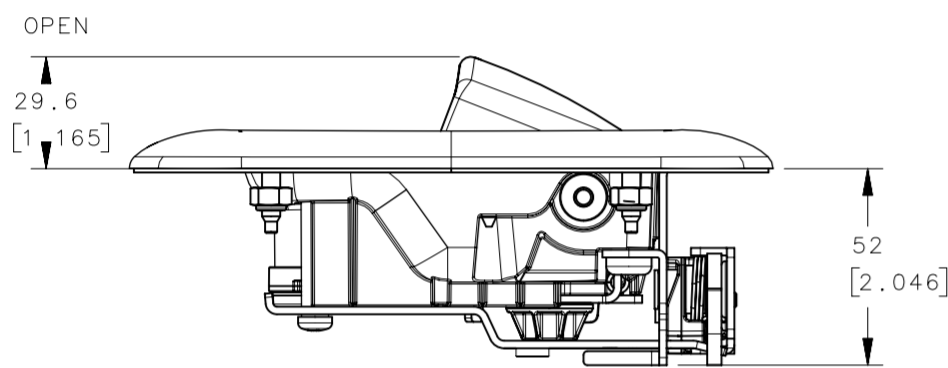

STANDARD LATCH WITHOUT BUMPER OPTION

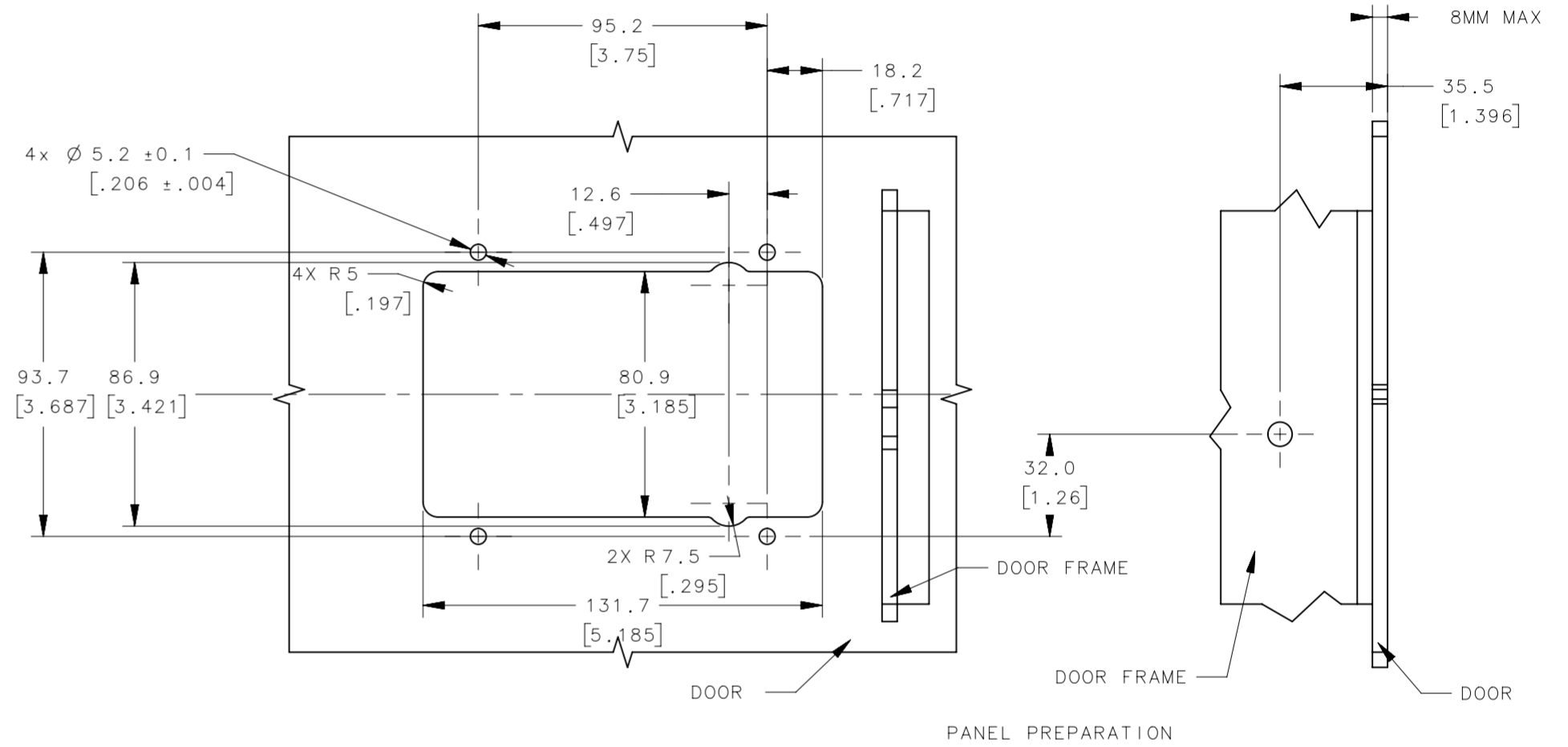
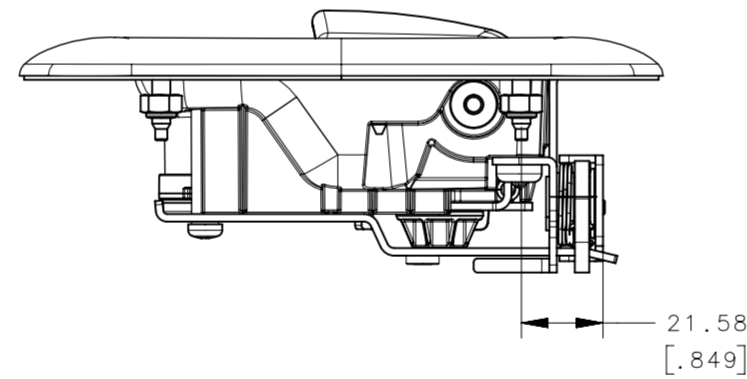
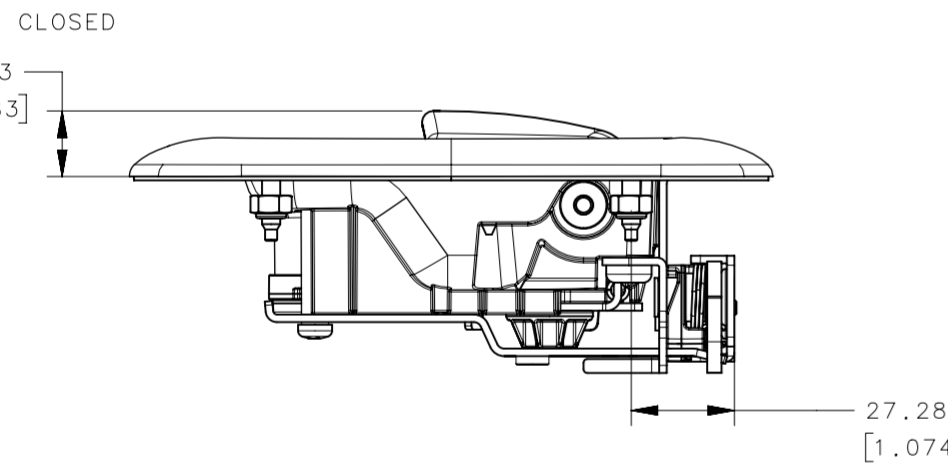
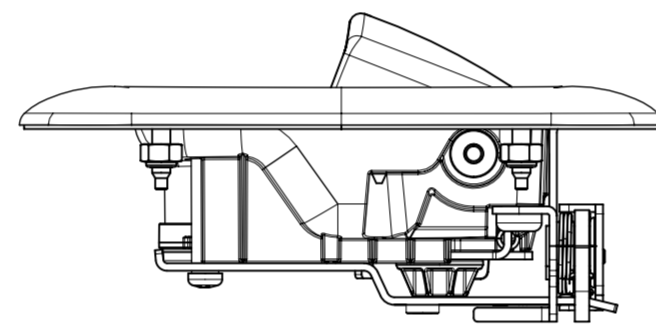

- NOTES:
 A: FOR KC=MK10, MASTER KEY PART NUMBER:PK-24-01
 B: INSTALLATION TORQUE OF MOUNTING NUTS NOT TO EXCEED 3N.m
 C: MATERIAL AND FINISH
 CUP: NYLON;BLACK
 PADDLE: ZAMAC 3; FINISH OPTIONS
 SLIDE: STEEL; ZINC PLATE; BRIGHT CHROMATE PLUS SEALER
 PIN: STEEL; ZINC PLATE
 LINK LEVER:STEEL;ZINC PLATE; BRIGHT CHROMATE PLUS SEALER
 ROCKER ARM:STEEL;ZINC PLATE; BRIGHT CHROMATE PLUS SEALER
 PADDLE ARM: ZAMAC 3 ;PASSIVATED
 PADDLE ARM CAP: ZAMAC 3 ;PASSIVATED
 O-RING: NITRILE; BLACK
 SCREWS: STEEL;ZINC PLATE; BRIGHT CHROMATE PLUS SEALER
 TORSION SPRING OF SLIDE: MUSIC SPRING ;NATURAL
 COMPRESSION SPRING: STAINLESS STEEL;PASSIVATED
 GASKET: FOAM;BLACK
 NUT: STEEL;ZINC PLATE
 BUMPER: EPDM;BLACK
 RETAINER: POM; BLACK

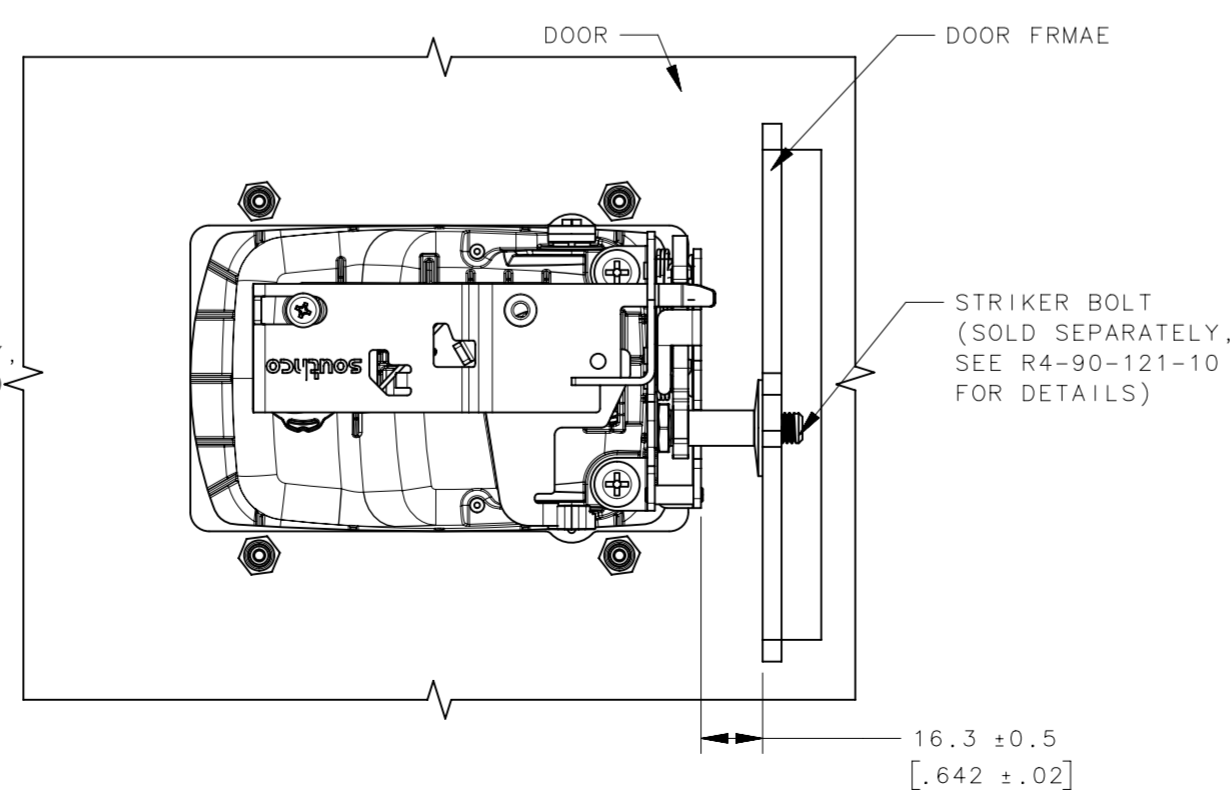
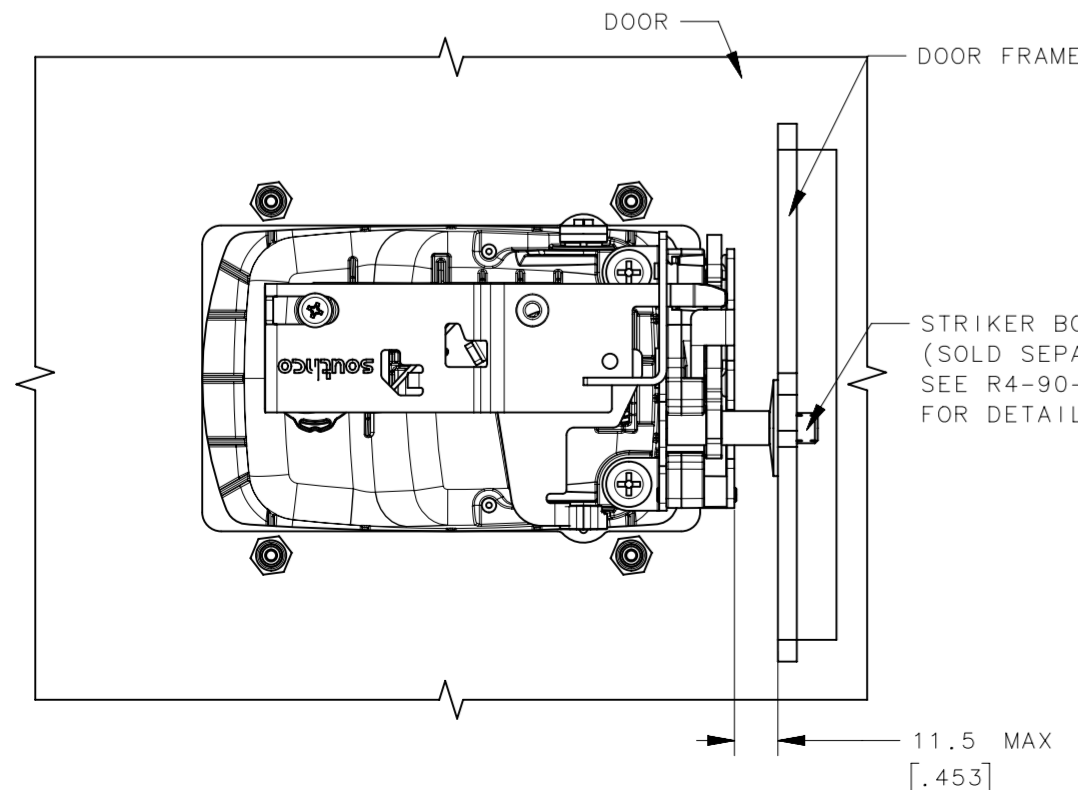

THIRD ANGLE PROJECTION		southco CONNECT · CREATE · INNOVATE
MILLIMETERS [IN]		
TOLERANCES UNLESS OTHERWISE NOTED	DESCRIPTION	ROTARY PADDLE LATCH ASSEMBLY
ALL DIMENSIONS WITHOUT TOLERANCES ARE FOR REFERENCE ONLY.	SIZE SYSTEM	DWG NO. J-R4-81
PROPRIETARY ITEM EXCEPT FOR USES EXPRESSLY GRANTED IN WRITING. INFORMATION DISCLOSED HEREON IS CONFIDENTIAL AND ALL RIGHTS, PATENT AND OTHERWISE, ARE RESERVED BY SOUTHCO, INC.	SCALE	1:1
PER ASME Y14.5M-1994	DATE	02JUL2015
	SHEET	1 OF 1