

REVISION HISTORY			
REV	DATE	BY	DESCRIPTION
G	22FEB2016	LAD/IGS	PRN: P2016-0369

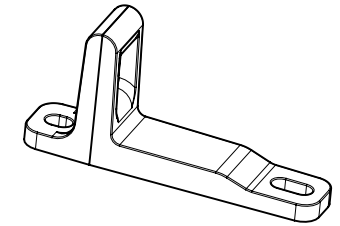

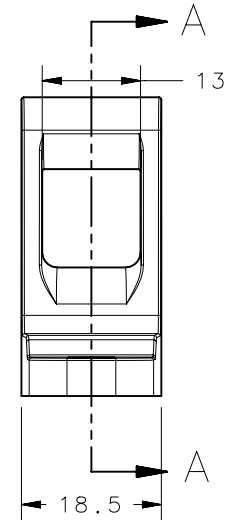

SCALE 1:2

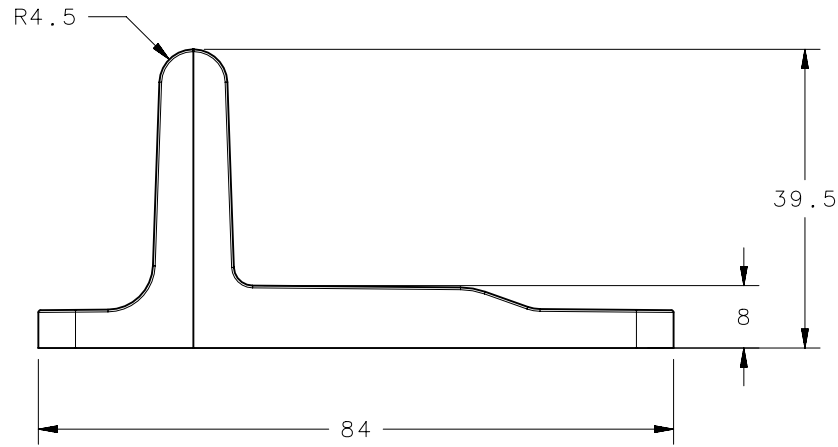
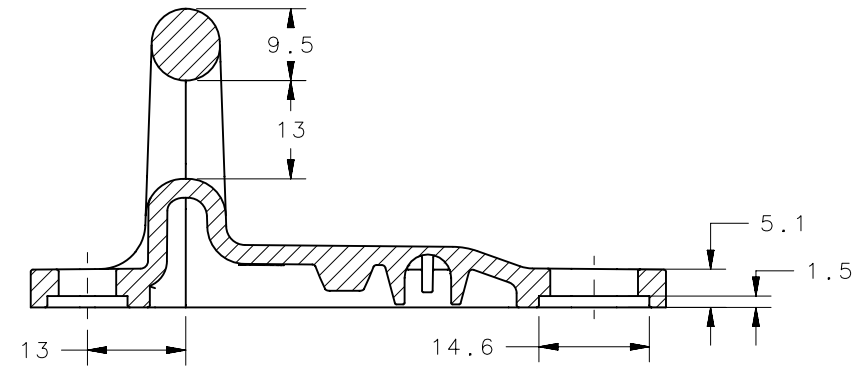
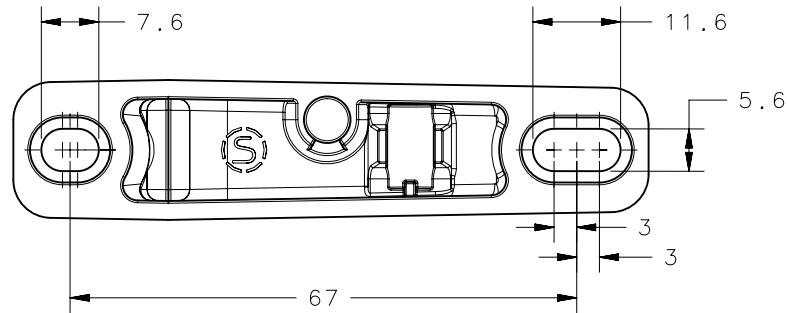

SECTION A-A

NOTES:

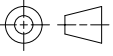
1. MOUNT STRIKER TO RIGID SURFACE AND SECURE WITH M5 OR #10 FASTENERS THROUGH PROVIDED SLOTS. FASTENERS NOT PROVIDED.

R4-91-700-20	STRIKER	STAINLESS STEEL	ELECTROPOLISHED
PART NUMBER	TYPE OF COMPONENT	MATERIAL	FINISH
	THIRD ANGLE PROJECTION 	 CONNECT • CREATE • INNOVATE	
	MILLIMETERS [IN]		
	TOLERANCES UNLESS OTHERWISE NOTED	DESCRIPTION	
	ALL DIMENSIONS WITHOUT TOLERANCES ARE FOR REFERENCE ONLY.	STRIKER WITHOUT MAGNET	
PROPRIETARY ITEM EXCEPT FOR USES EXPRESSLY GRANTED IN WRITING, INFORMATION DISCLOSED HEREON IS CONFIDENTIAL AND ALL RIGHTS, PATENT AND OTHERWISE, ARE RESERVED BY SOUTHCO, INC.	PER ASME Y14.5M-1994	SIZE A4 SYSTEM NX	DWG NO. J-R4-91-700-20
		DRAWN BY LAD	DATE 06MAY2015
		SCALE 1:1	SHEET 1 OF 1