

ASSEMBLY PART NUMBERS R4-EM - T B A - 1 S C - P M

REVISION HISTORY			
REV	DATE	BY	DESCRIPTION
H	21APR2021	HPD/VK	PRN: P2021-0765

- T TRIGGER STYLE**
 7 DELAYED RELOCK, SIDE TRIGGER
 R7 DELAYED RELOCK, REAR TRIGGER
- B BASE MOUNTING STYLE**
 1 1/4-20 THREADED MOUNTING
 2 M6 THREADED MOUNTING
 3 THRU HOLE MOUNTING
- A ALTERNATE CONFIGURATIONS**
 NONE LIGHT CAM SPRING
 2 STRONG (KICK OUT)CAM SPRING
 3 HIGH STRENGTH CAM (MATERIAL OPTION NONE OR C ONLY)
 4 STRONG (KICK OUT) CAM SPRING AND HIGH STRENGTH CAM (MATERIAL OPTION NONE OR C ONLY)
- S SWITCH OPTIONS**
 3 NO SWITCH
 6 SINGLE SWITCH (CAM ONLY)
 7 DUAL SWITCH (CAM AND TRIGGER)
- C CONNECTOR OPTIONS**
 1 STANDARD CONNECTOR
 2 NO CONNECTOR (STRIPPED AND TINNED)
 3 SEALED CONNECTOR
- P PACKAGING OPTIONS**
 NONE INDIVIDUALLY PACKAGED
 1 BULK PACKAGED
- M MATERIAL OPTIONS**
 NONE STEEL PLATED
 B STAINLESS STEEL (ALT CONFIG NONE OR 2 ONLY)
 C STEEL, PLATED, UL CLASS 1 DIV 2
 D STAINLESS STEEL, UL CLASS 1 DIV 2 (ALT CONFIG NONE OR 2 ONLY)

NOTES:

- A**=(NONE)LIGHT CAM SPRING, IS A LOW FORCE SPRING INTENDED TO PROVIDE MINIMAL KICKOUT FORCE AT THE CAM IN THE OPENING DIRECTION. APPROXIMATE FORCE WITH CAM IN CLOSED POSITION, FORCE= 1.5 N
- A**=2 STRONG (KICKOUT OUT)SPRING, IS INTENDED TO PROVIDE A KICKOUT FORCE AT THE CAM IN THE OPENING DIRECTION. APPROXIMATE FORCE WITH CAM IN CLOSED POSITION, FORCE= 6.4 N

S=6 SINGLE SWITCH (CAM ONLY)

CAM STATUS INDICATOR CIRCUIT

	CAM POSITION	
	CAM OPEN	CAM CLOSED
BLACK/GREY WIRES	CLOSED CIRCUIT	OPEN CIRCUIT
BLACK/BLUE WIRES	OPEN CIRCUIT	CLOSED CIRCUIT

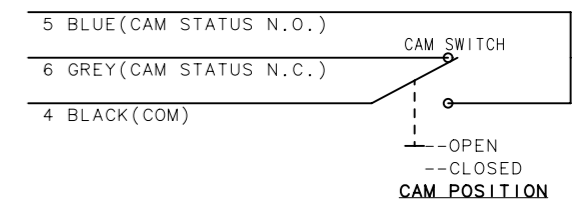

S=7 DUAL SWITCH (CAM AND TRIGGER)

LATCH STATUS INDICATOR CIRCUIT CONDITIONS FOR BLACK AND BLUE WIRES

TRIGGER POSITION		CAM POSITION	
		CAM OPEN	CAM CLOSED
LOCKED	OPEN CIRCUIT	CLOSED CIRCUIT	OPEN CIRCUIT
UNLOCKED	OPEN CIRCUIT	OPEN CIRCUIT	OPEN CIRCUIT

CAM STATUS INDICATOR CIRCUIT CONDITIONS FOR BLACK AND GREY WIRES

CAM POSITION	
CAM OPEN	CAM CLOSED
CLOSED CIRCUIT	OPEN CIRCUIT

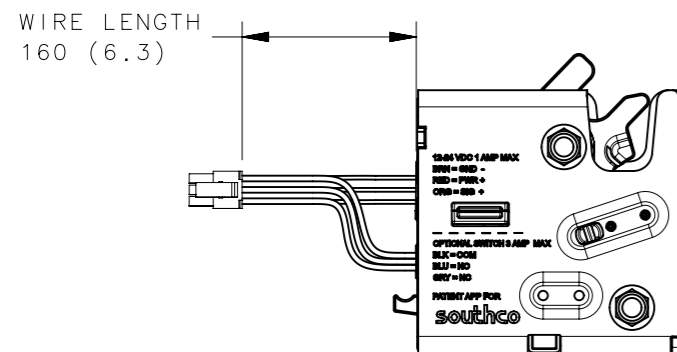
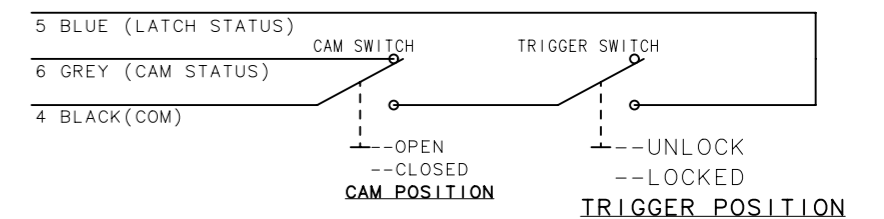

R4-EM-7BA-1S1-PM
SIDE TRIGGER WITH STANDARD CONNECTOR

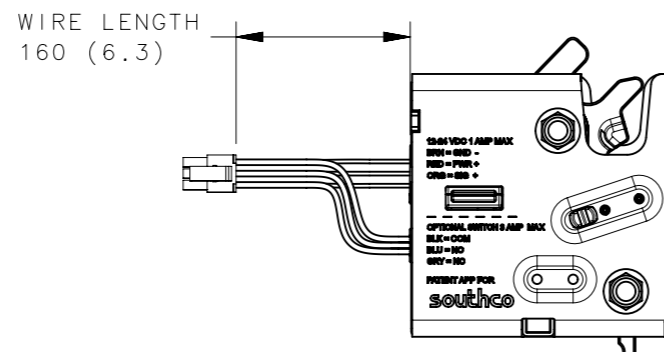

R4-EM-R7BA-1S1-PM
REAR TRIGGER WITH STANDARD CONNECTOR

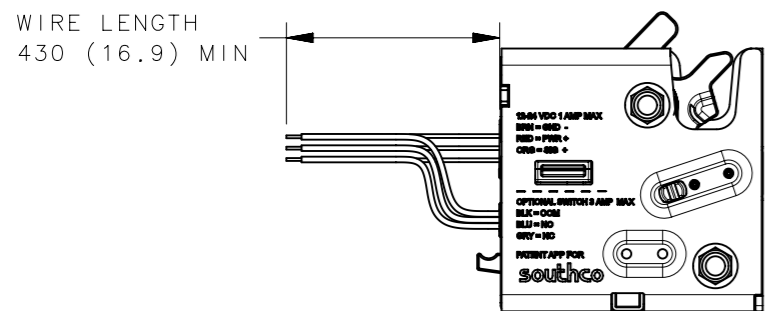

R4-EM-7BA-1S2-PM
SIDE TRIGGER WITH NO CONNECTOR

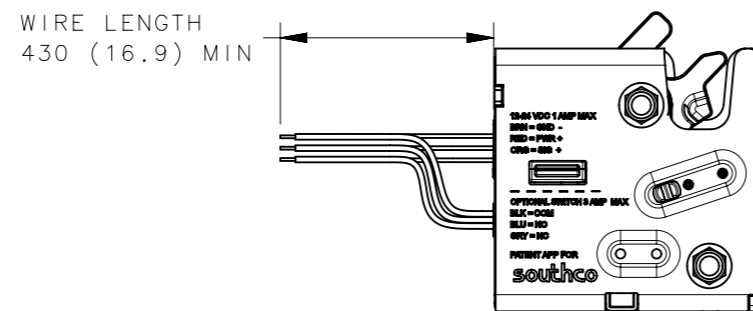

R4-EM-R7BA-1S2-PM
REAR TRIGGER WITH NO CONNECTOR

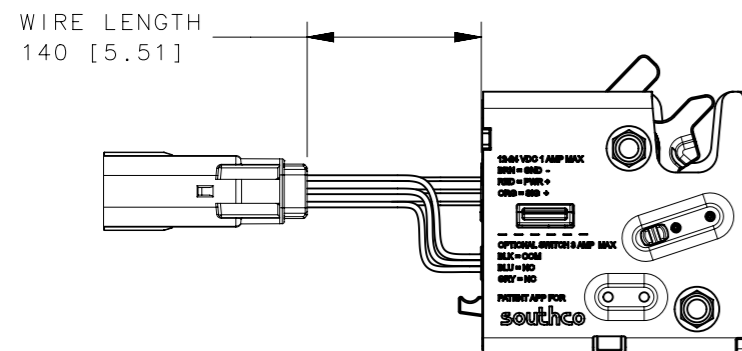

R4-EM-7BA-1S3-PM
SIDE TRIGGER WITH SEALED CONNECTOR

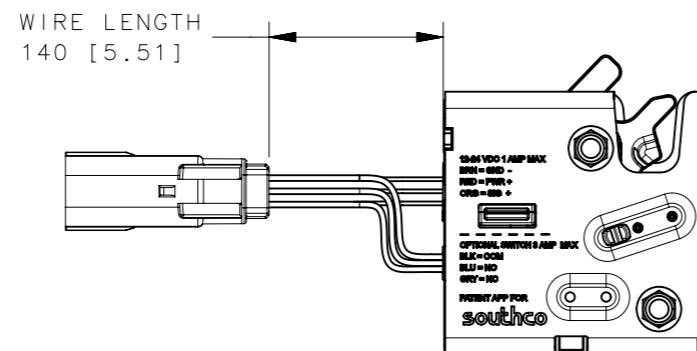

R4-EM-R7BA-1S3-PM
REAR TRIGGER WITH SEALED CONNECTOR

THIRD ANGLE PROJECTION			 CONNECT • CREATE • INNOVATE	
MILLIMETERS [IN]				
SURFACE AREA	TOLERANCES UNLESS OTHERWISE NOTED	DESCRIPTION R4-EM OUTDOOR ROTARY LATCH DELAYED RELOCK		
VOLUME	ALL DIMENSIONS WITHOUT TOLERANCES ARE FOR REFERENCE ONLY.	SIZE A3	SYSTEM NX	DWG NO. J-R4-EM-7-1
PROPRIETARY ITEM EXCEPT FOR USES EXPRESSLY GRANTED IN WRITING, INFORMATION DISCLOSED HEREON IS CONFIDENTIAL AND ALL RIGHTS, PATENT AND OTHERWISE, ARE RESERVED BY SOUTHCO, INC.	PER ASME Y14.5M-1994	DRAWN BY DJK/GGG	DATE 15OCT2013	SCALE NTS
				SHEET 1 OF 4

REVISION HISTORY			
REV	DATE	BY	DESCRIPTION
H	21APR2021	HPD/VK	PRN: P2021-0765

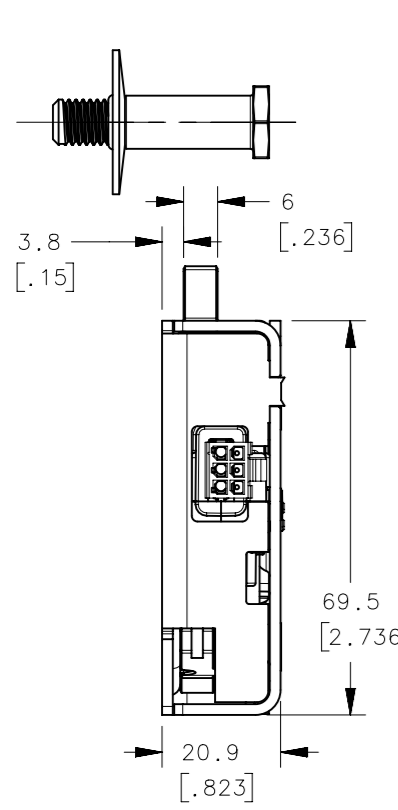

R4-EM-7BA-1S1-PM
SIDE TRIGGER (SHOWN IN THE
LOCKED POSITION, NO SWITCH,
STANDARD CONNECTOR SHOWN

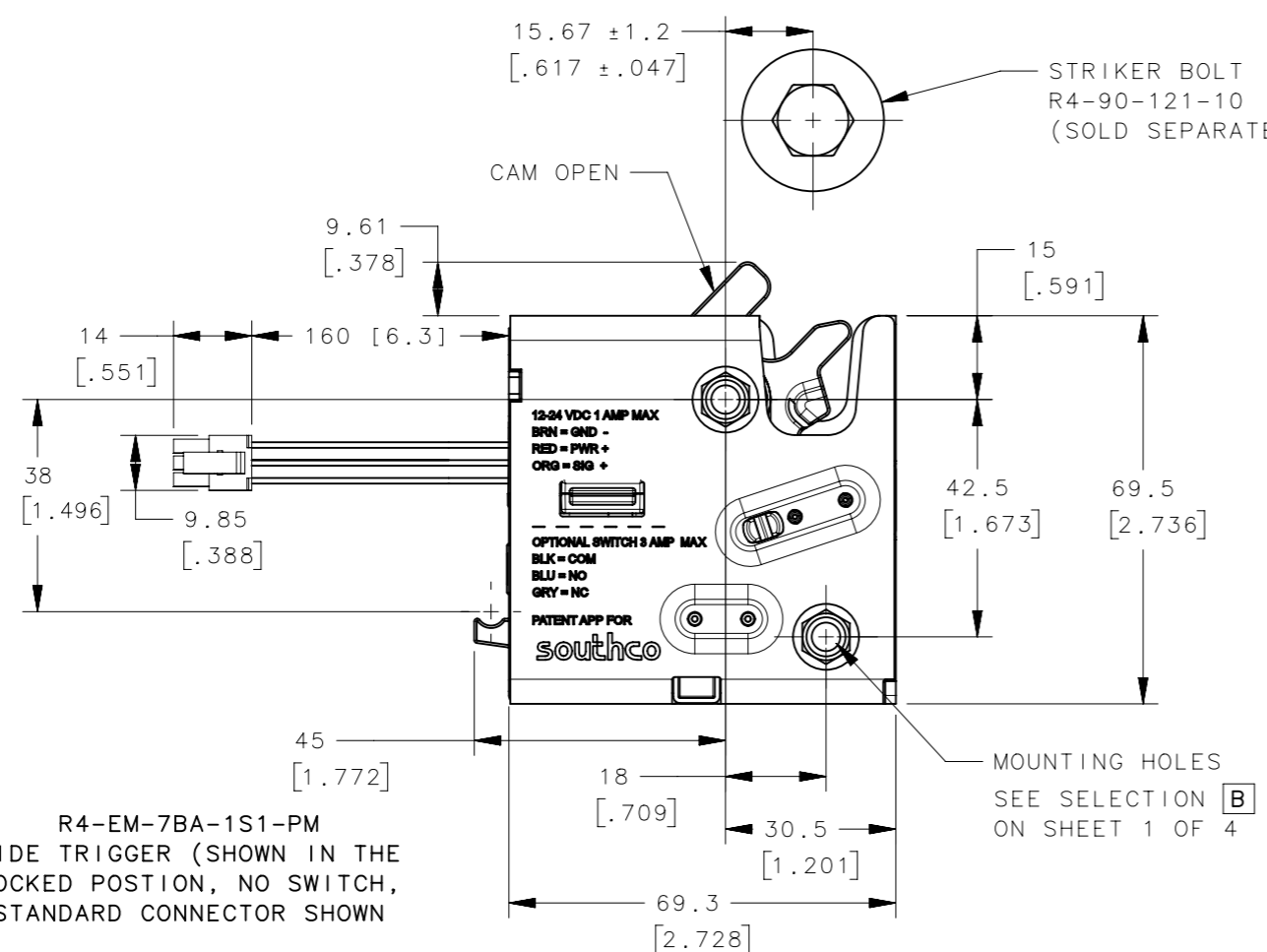

STRIKER BOLT
R4-90-121-10
(SOLD SEPARATE)

CAM OPEN

MOUNTING HOLES
SEE SELECTION **B**
ON SHEET 1 OF 4

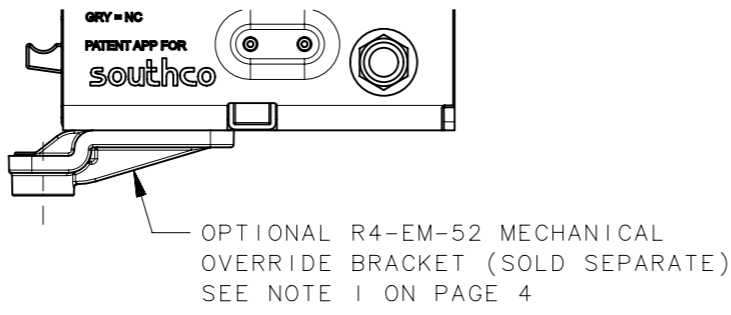
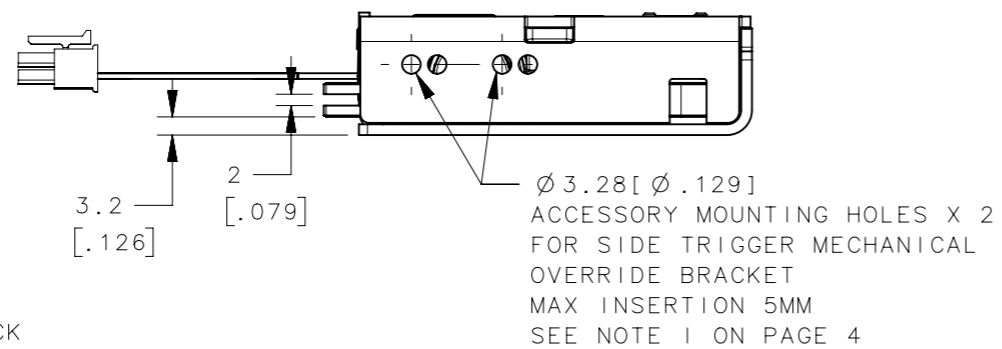

OPTIONAL R4-EM-52 MECHANICAL
OVERRIDE BRACKET (SOLD SEPARATE)
SEE NOTE 1 ON PAGE 4

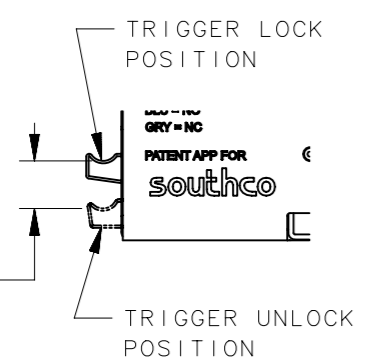

TRIGGER TRAVEL DETAIL

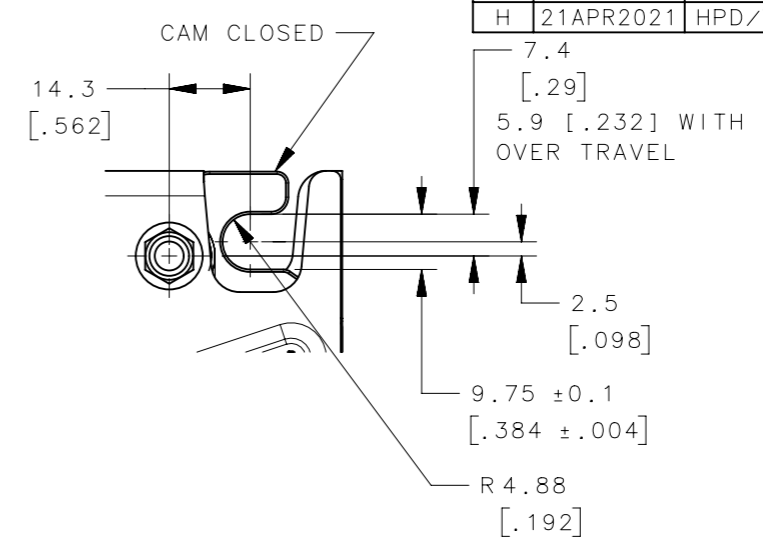

CAM CLOSED

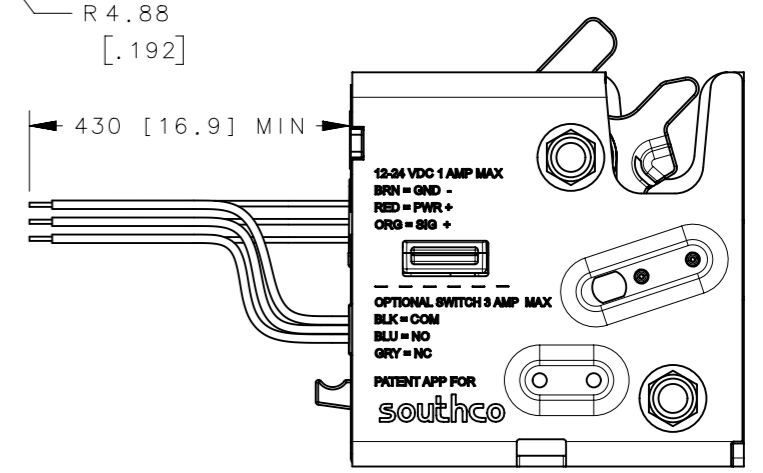

SIDE TRIGGER, NO CONNECTOR MODELS
R4-EM-7BA-1S2-PM

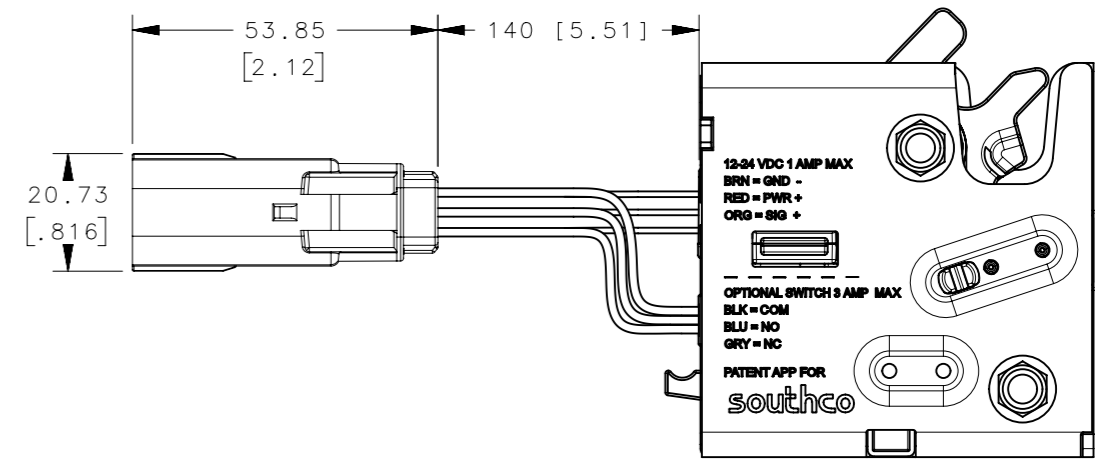

SIDE TRIGGER, SEALED CONNECTOR MODELS
R4-EM-7BA-1S3-PM

SIDE TRIGGER MODELS R4-EM-7BA-1SC-PM

THIRD ANGLE PROJECTION		 CONNECT · CREATE · INNOVATE	
MILLIMETERS [IN]			
TOLERANCES UNLESS OTHERWISE NOTED		DESCRIPTION R4-EM OUTDOOR ROTARY LATCH DELAYED RELOCK	
ALL DIMENSIONS WITHOUT TOLERANCES ARE FOR REFERENCE ONLY.		SIZE A3	SYSTEM NX
PER ASME Y14.5M-1994		DWG NO. J-R4-EM-7-1	DATE 15OCT2013
PROPRIETARY ITEM EXCEPT FOR USES EXPRESSLY GRANTED IN WRITING, INFORMATION DISCLOSED HEREON IS CONFIDENTIAL AND ALL RIGHTS, PATENT AND OTHERWISE, ARE RESERVED BY SOUTHCO, INC.		SCALE NTS	SHEET 2 OF 4

REVISION HISTORY			
REV	DATE	BY	DESCRIPTION
H	21APR2021	HPD/VK	PRN: P2021-0765

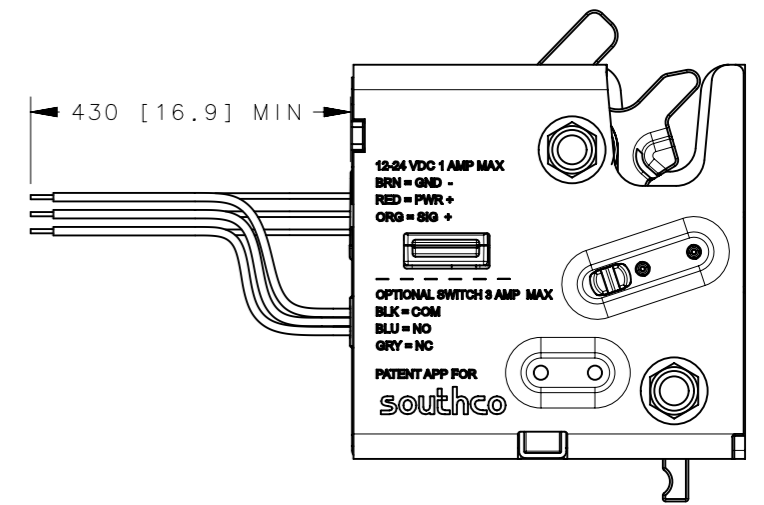
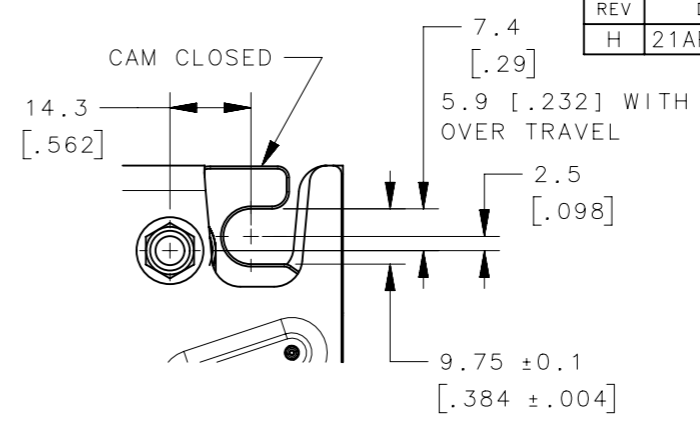
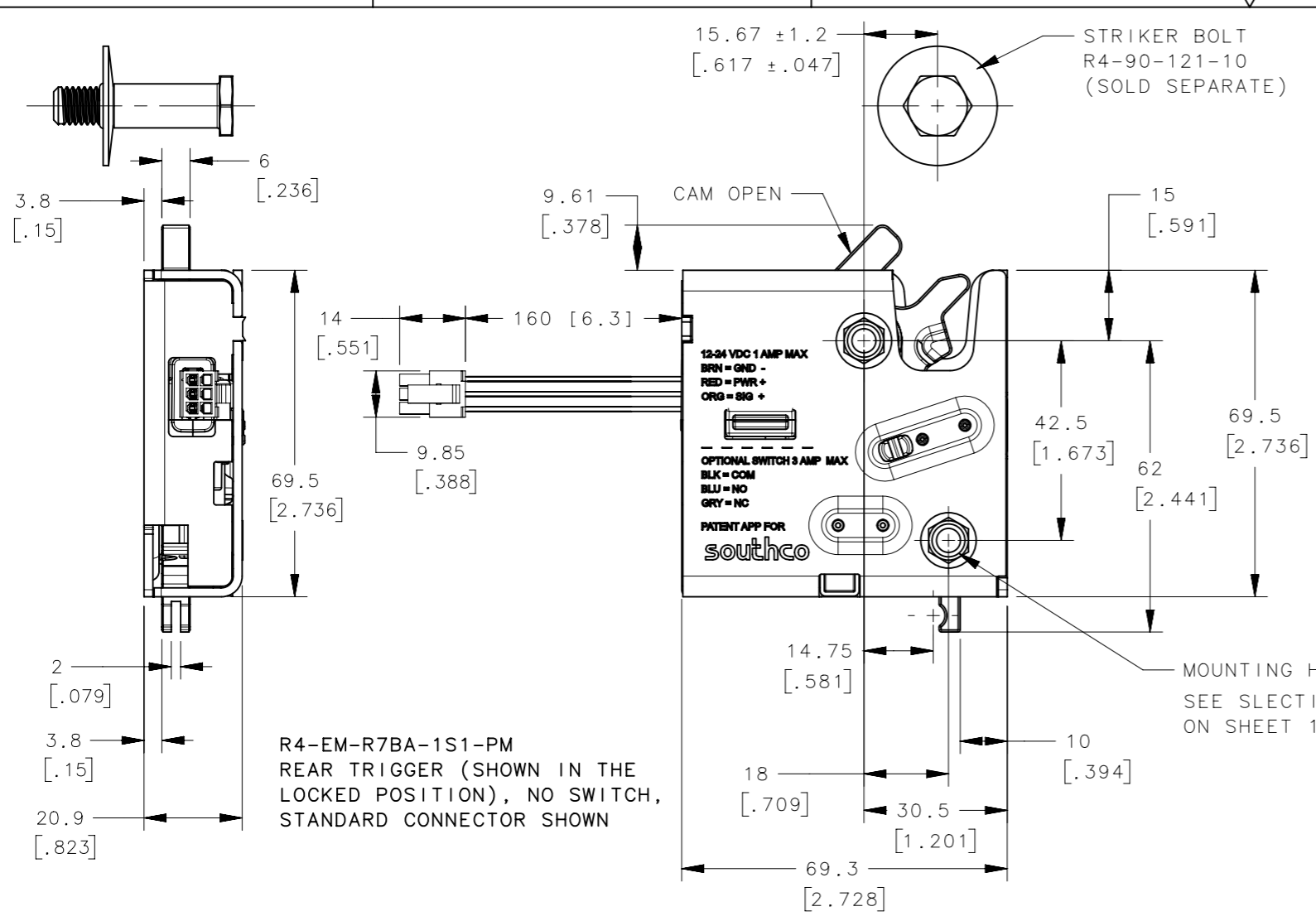

REAR TRIGGER, NO CONNECTOR MODELS
R4-EM-R7BA-1S2-PM

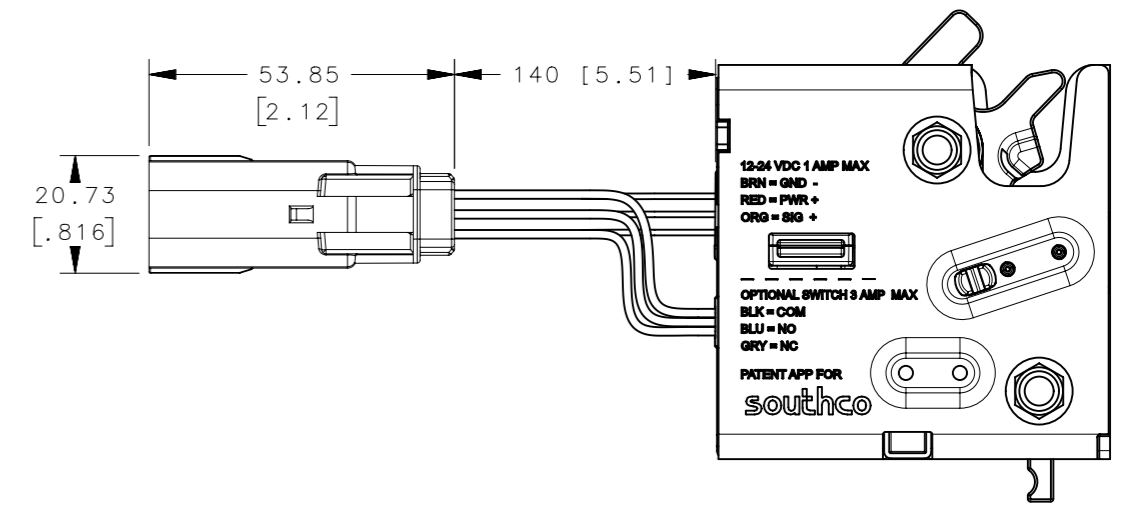
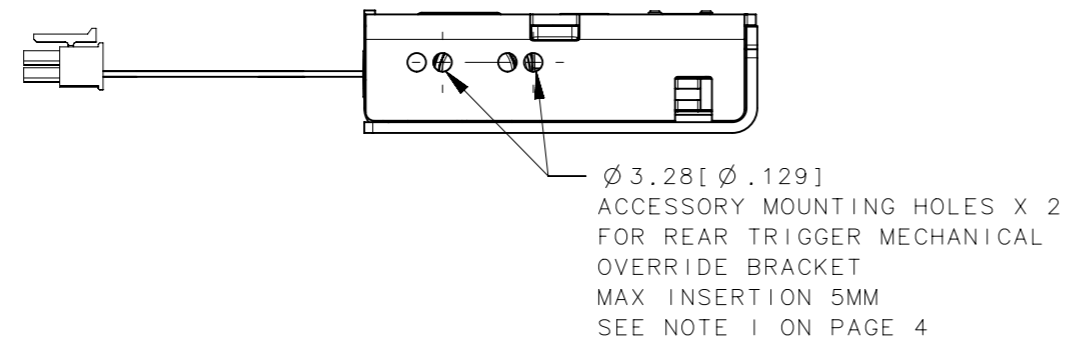

REAR TRIGGER, SEALED CONNECTOR MODELS
R4-EM-R7BA-1S3-PM

REAR TRIGGER MODELS R4-EM-R7BA-1SC-PM

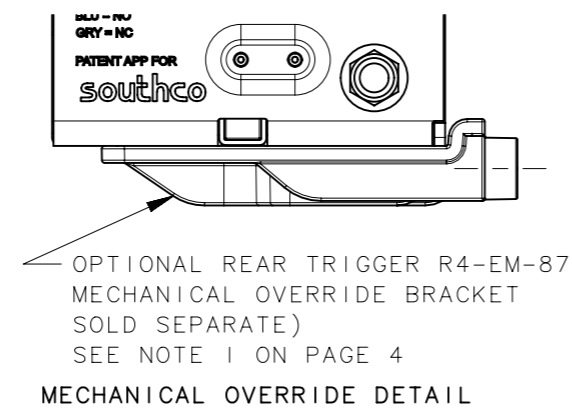
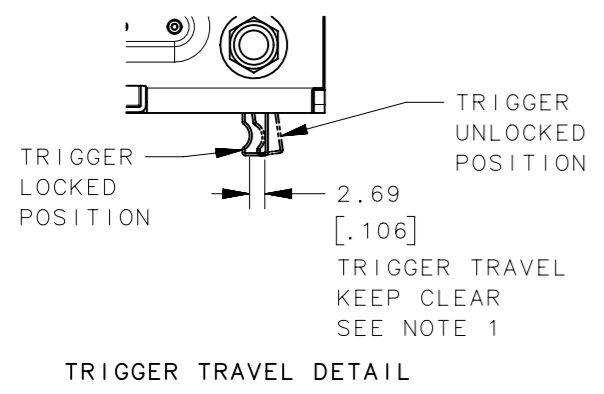

	THIRD ANGLE PROJECTION	southco CONNECT • CREATE • INNOVATE	
	MILLIMETERS [IN]		
SURFACE AREA	TOLERANCES UNLESS OTHERWISE NOTED	DESCRIPTION R4-EM OUTDOOR ROTARY LATCH DELAYED RELOCK	
VOLUME	ALL DIMENSIONS WITHOUT TOLERANCES ARE FOR REFERENCE ONLY.	SIZE A3	SYSTEM NX
PROPRIETARY ITEM EXCEPT FOR USES EXPRESSLY GRANTED IN WRITING, INFORMATION DISCLOSED HEREON IS CONFIDENTIAL AND ALL RIGHTS, PATENT AND OTHERWISE, ARE RESERVED BY SOUTHCO, INC.	PER ASME Y14.5M-1994	DWG NO. J-R4-EM-7-1	DATE 15OCT2013
		DRAWN BY DJK/GGG	SCALE NTS
			SHEET 3 OF 4

REVISION HISTORY			
REV	DATE	BY	DESCRIPTION
H	21APR2021	HPD/VK	PRN: P2021-0765

- NOTES:
- A. MATERIAL AND FINISH
HOUSINGS: STEEL ZINC-NICKEL PLATED. (OPTIONAL 304 STAINLESS STEEL)
CAM AND TRIGGERS: STEEL PLATED. (OPTIONAL STAINLESS STEEL POWDER METAL 19.72% CHROMIUM / 17.82% NICKEL)
PINS: STEEL ZINC-NICKEL PLATED. (OPTIONAL 304 STAINLESS STEEL)
SPRINGS: 304 STAINLESS STEEL
ELECTRONIC ACTUATOR: PLASTIC (PC/ABS AND ACETAL), SILICONE AND BUNA SEALS, AND METAL COMPONENTS
- B. ELECTRICAL SPECIFICATIONS:
ACTUATOR AND SWITCH SEALED TO IP56.
OPERATING VOLTAGE: 12 TO 24 VDC NOMINAL
TYPICAL OPERATING CURRENT: LESS THAN 500 MILLIAMPS AT 12 VDC
PEAK / STALL OPERATING CURRENT: 1A MAX (STALL LIMITED TO 1.4 SECONDS)
TOTAL STANDBY CURRENT: LOCKED: LESS THAN 100 MICROAMPS
UNLOCKED: LESS THAN 10 MILLIAMPS AT 12 TO 24 VDC
CONTROL SIGNAL HIGH (UNLOCK COMMAND): 6 VDC TO OPERATING VOLTAGE, 5.5 MILLIAMPS MAX
CONTROL SIGNAL LOW (LATCHED COMMAND): 0 TO 1 VDC (OPEN)
LATCH TRANSIT TIME TO RELEASE: 600 MILLISECONDS NO LOAD, 1.4 SECOND MAX
OPERATING TEMPERATURE RANGE: -40C TO +80C
- C. ELECTRICAL CONNECTIONS AND HOOKUP:
A BASIC SWITCH CONTROL ELECTRICAL HOOKUP DIAGRAM IS PROVIDED FOR REFERENCE.
CONSULT WITH A SOUTHCO REPRESENTATIVE FOR ADDITIONAL ELECTRICAL HOOKUP INFORMATION.
- CONNECT POWER, GROUND AND CONTROL SIGNAL WIRES TO AN APPROPRIATE DC POWER SUPPLY
- A DC POWER SUPPLY CAPABLE OF SUPPLYING 12 TO 24 VDC AT 1 AMP MINIMUM PER LATCH IS RECOMMENDED
- POWER MUST BE AVAILABLE TO OPERATE THE LATCH AND MUST REMAIN AVAILABLE DURING THE FULL TRANSIT TIME OF THE LATCH DURING LOCKING OR UNLOCKING
CAUTION! LATCH CAN BE DAMAGED IF WIRED INCORRECTLY, OR IF IMPROPER VOLTAGE IS APPLIED!
WIRE COLOR CODE / CONNECTOR PIN ASSIGNMENT: SEE CONNECTOR PINOUT TABLE AND PIN LOCATION DETAILS

- F. OPTIONAL NON-SEALED LATCH CONNECTOR:
MANUFACTURER: MOLEX, SERIES: MICROFIT 3.0
- CONNECTOR RECEPTICAL 6 POSITION 3mm VERTICAL DUAL, MOLEX P/N: 43025-0600
- CONTACTS: FEMALE CRIMP TERMINAL (SOCKET) MOLEX P/N: 43030-0007
WIRE: 22 AWG STYLE AWM 1569
WIRE LENGTH: SEE TABLE FOR AVAILABLE LENGTHS
MATE FOR NON-SEALED CONNECTOR (NOT SUPPLIED)
MANUFACTURER: MOLEX, SERIES: MICROFIT 3.0
- CONNECTOR PLUG 6 POSITION 3 mm VERTICAL DUAL, MOLEX P/N: 43020-0601
- RECOMMENDED CONTACTS (6 MAX REQUIRED): MOLEX, MALE CRIMP TERMINAL (PIN), MOLEX P/N: 43031-XXXX
- RECOMMENDED WIRE GAGE: 22 AWG
- G. OPTIONAL SEALED LATCH CONNECTOR:
MANUFACTURER: MOLEX, SERIES: MX150
- CONNECTOR SEALED MALE, 6 POSITION DUAL ROW, 3.50mm PITCH MX150, POLARIZATION A, MOLEX P/N: 33482-0601
- CONTACTS: MOLEX, MALE CRIMP TERMINAL, TIN, MOLEX P/N: 33000-0003
WIRE: 22 AWG STYLE AWM 1569
WIRE LENGTH: SEE TABLE FOR AVAILABLE LENGTHS
MATE FOR SEALED LATCH CONNECTOR (NOT SUPPLIED)
MANUFACTURER: MOLEX, SERIES: MX150
- CONNECTOR SEALED FEMALE, 6 POS DUAL ROW, 3.50 mm PITCH MX150, POLARIZATION A, MOLEX P/N: 33472-0601
- RECOMMENDED CONTACTS (6 MAX REQUIRED): MOLEX, FEMALE CRIMP TERMINAL, TIN 18-22 AWG, MOLEX P/N: 33012-2003
- RECOMMENDED WIRE GAGE: 22 AWG
- H. MOUNTING
- MOUNT THE LATCH SECURELY USING TWO (2) SCREWS IN MOUNTING HOLES PROVIDED (SCREWS NOT PROVIDED)
- MOUNTING HOLES ARE AVAILABLE WITH 1/4 - 20 UNC THREAD, M6 X 1 THREAD OR THRU HOLE
- MAXIMUM ALLOWABLE TORQUE ON THREADED MOUNTING SCREWS IS 650 N.cm (57.5 in.lb)
- I. MECHANICAL OPERATION:
THE LATCH IS PROVIDED WITH A MECHANICAL TRIGGER TO RELEASE THE LATCH.
SEE TRIGGER DETAIL VIEWS FOR SIDE AND REAR TRIGGER MODELS ON PAGE 3 AND 4 FOR TRIGGER TRAVELS.
THE TRIGGER MOVES THROUGH ITS FULL TRAVEL DURING ELECTRICAL OPERATION OF THE LATCH.
CAUTION! IT IS IMPORTANT TO NOT OBSTRUCT THE MOTION OF THE TRIGGER DURING ELECTRICAL OPERATION TO PREVENT LONG TERM DAMAGE TO THE ELECTRICAL COMPONENTS IN THE LATCH. TWO HOLES PROVIDED CAN BE USED TO MOUNT MECHANICAL OVERRIDE LINKAGE RETAINING BRACKETS. STANDARD 1/8" BLIND RIVETS CAN BE USED FOR FASTENING. FOLLOW MAX INSERTION DEPTH INDICATED AND ENSURE THAT NO PARTICLES ENTER THE LATCH. CONTACT SOUTHCO FOR MECHANICAL RELEASE CABLES AND ACTUATORS. AN OPTIONAL KIT WITH ONE CABLE MOUNTING BRACKET AND TWO RIVETS IS AVAILABLE AS P/N: R4-EM-52 FOR SIDE TRIGGER CONFIGURATION OR P/N: R4-EM-87 FOR REAR TRIGGER CONFIGURATION. SEE CUSTOMER DRAWING J-R4-EM-52 OR J-R4-EM-87 FOR MORE INFORMATION.
- J. STRIKER BOLT ASSEMBLY SOLD SEPARATELY
STRIKER BOLT PART NUMBER R4-90-121-10. REFER TO CUSTOMER DRAWING J-R4-90-121 FOR ADDITIONAL INFORMATION.
- K. PACKAGED IN INDIVIDUAL BOXES OR ADD -1 TO PART NUMBER FOR BULK PACKAGING
EXAMPLE: R4-EM-X7X-1XX: PACKAGED ONE UNIT PER BOX
R4-EM-X7X-1XX-1: PACKAGED IN BULK, 30 PER BOX.

CONNECTOR PINOUT		
PIN	WIRE COLOR	FUNCTION
1	BROWN	GROUND (-)
2	RED	POWER (+)
3	ORANGE	CONTROL SIGNAL
4	BLACK	SWITCH COMMON
5	BLUE	SWITCH N.O.
6	GREY	SWITCH N.C.

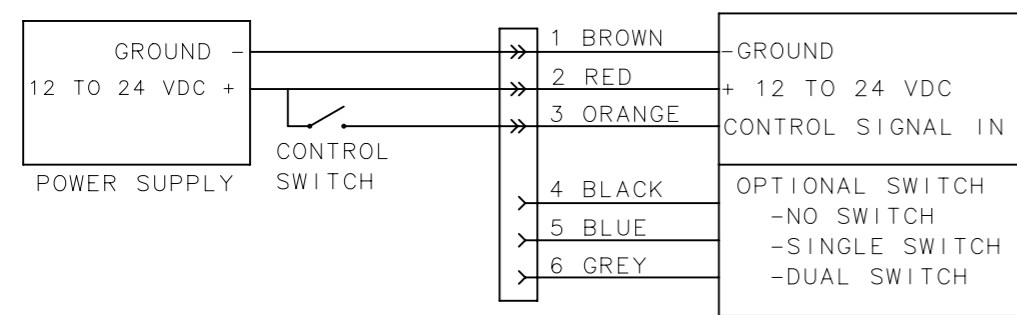
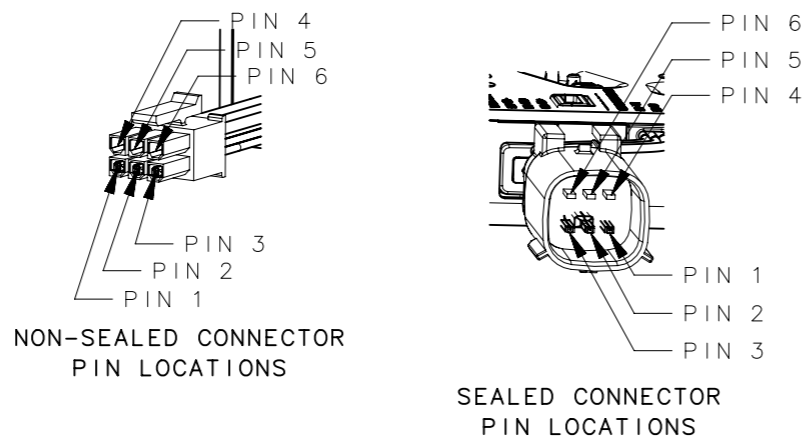

ELECTRICAL HOOKUP (SWITCH CONTROL)

- D. ELECTRICAL OPERATION:
- TO UNLOCK OR RELEASE THE LATCH:
PROVIDE THE FOLLOWING CONTROL SIGNAL TO THE ORANGE WIRE OR CONNECTOR PIN 3
- PROVIDE 12 TO 24 VDC (CONTROL SIGNAL HIGH) FOR A MINIMUM OF 50 MILLISECONDS
- THE CONTROL SIGNAL CAN REMAIN HIGH INDEFINITELY
- THE LATCH WILL STAY UNLOCKED FOR A MINIMUM OF 20 MILLISECONDS OR AS LONG AS THE SIGNAL IS HIGH
- TO LOCK THE LATCH:
PROVIDE THE FOLLOWING CONTROL SIGNAL TO THE ORANGE WIRE OR CONNECTOR PIN 3
- PROVIDE CONTROL SIGNAL LOW FOR 50 MILLISECONDS. POWER MUST BE AVAILABLE DURING TRANSIT TO LOCKED POSITION.

- NOTE:
- THE DOOR IS NOT LATCHED WHEN IN THE UNLOCKED POSITION. ENSURE THAT YOUR DOOR IS BIASED CLOSED OR DETENTED IN THE CLOSED POSITION. THE CAM MUST REMAIN IN THE CLOSED POSITION TO RE-LOCK.
- FROM THE LOCKED POSITION WITH THE CAM IN THE OPEN POSITION, THE DOOR CAN BE PUSHED TO CLOSED AND WILL LOCK.
- E. OPTIONAL POSITION FEEDBACK SWITCHES:
- NO SWITCH: MODELS WITHOUT SWITCH WILL NOT HAVE BLACK, BLUE OR GREY WIRES
- SINGLE SWITCH: CAM ONLY STATUS INDICATOR CIRCUIT. SEE PAGE 1 OF 4 FOR OUTPUT AND SCHEMATIC.
- DUAL SWITCH: CAM AND TRIGGER LATCH STATUS INDICATOR CIRCUIT, AND CAM STATUS INDICATOR CIRCUIT.
- SEE PAGE 1 OF 4 FOR OUTPUT AND SCHEMATIC.
SWITCH RATINGS: 3 AMP MAX AT 12 VDC
WARNING! SWITCH CIRCUIT IS NOT FUSED OR ELECTRICALLY PROTECTED! USE APPROPRIATE EXTERNAL CIRCUIT PROTECTION.
WIRE SWITCH CORRECTLY PER ELECTRICAL HOOKUP DIAGRAM AND DO NOT SHORT CIRCUIT.
A SHORT CIRCUIT CAN DAMAGE LATCH AND MAY POSE AN ELECTRICAL FIRE HAZARD!

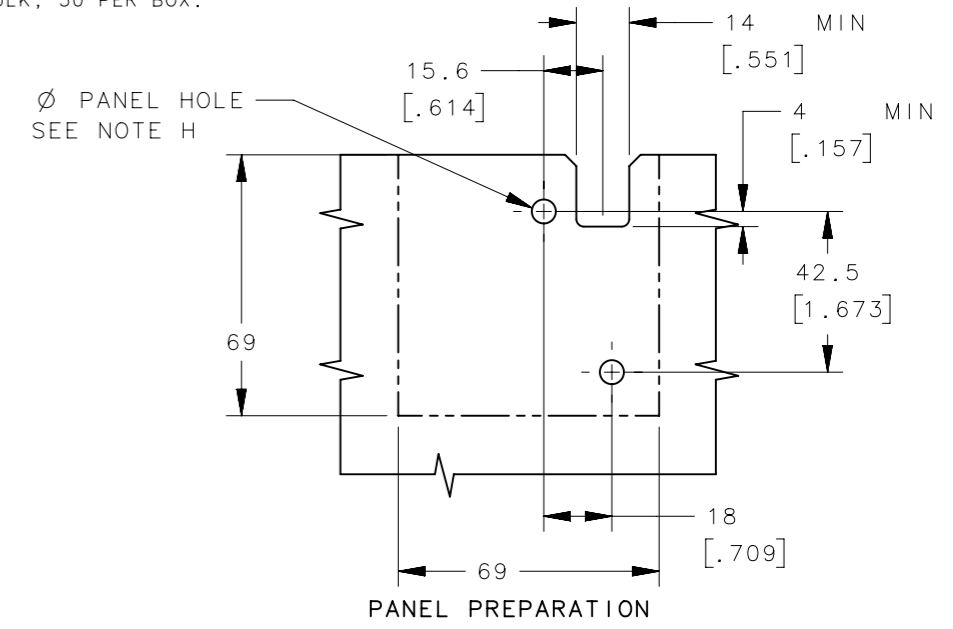

THIRD ANGLE PROJECTION		 CONNECT • CREATE • INNOVATE	
MILLIMETERS [IN]			
TOLERANCES UNLESS OTHERWISE NOTED		DESCRIPTION	
ALL DIMENSIONS WITHOUT TOLERANCES ARE FOR REFERENCE ONLY.		R4-EM OUTDOOR ROTARY LATCH DELAYED RELOCK	
SIZE	SYSTEM	DWG NO.	
A3	NX	J-R4-EM-7-1	
PER ASME Y14.5M-1994		DRAWN BY	DATE
		DJK/GGG	15OCT2013
		SCALE	SHEET
		NTS	4 OF 4