

REVISION HISTORY			
REV	DATE	BY	DESCRIPTION
B	25SEP2013	DJK/WJB	PRN: P2013-1922

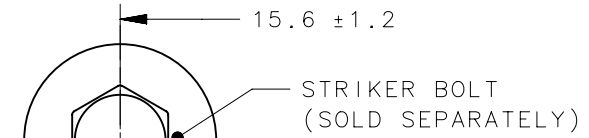

STRIKER BOLT
(SOLD SEPARATELY)

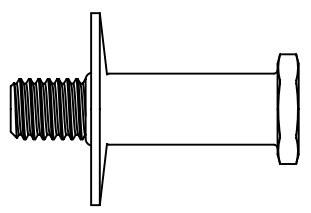
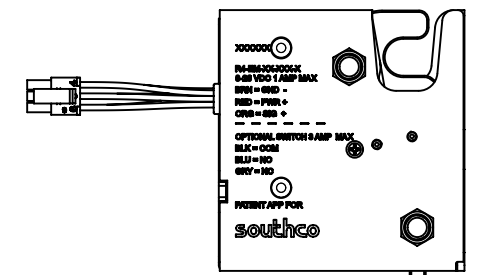
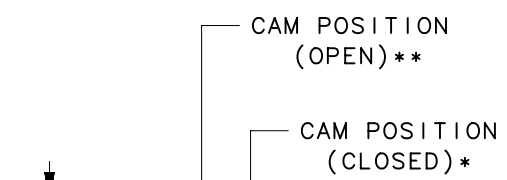

WITH SWITCH AND CONNECTOR
R4-EM-R11-161
R4-EM-R12-161
R4-EM-R13-161

TRIGGER TRAVEL (3 REF)
KEEP CLEAR
SEE NOTE 1

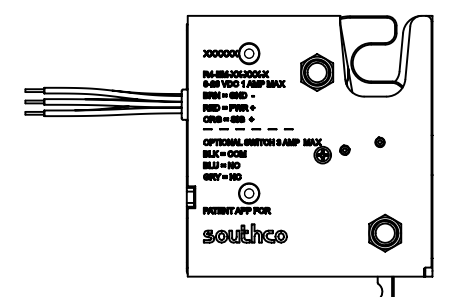
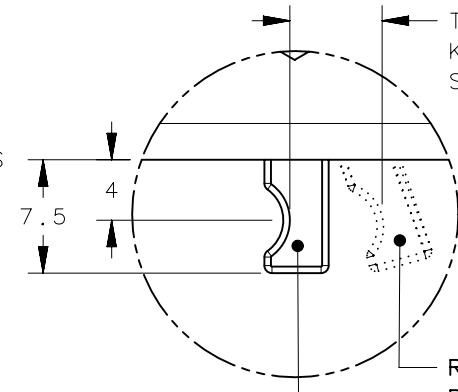

WITH SWITCH, NO CONNECTOR
R4-EM-R11-162
R4-EM-R12-162
R4-EM-R13-162

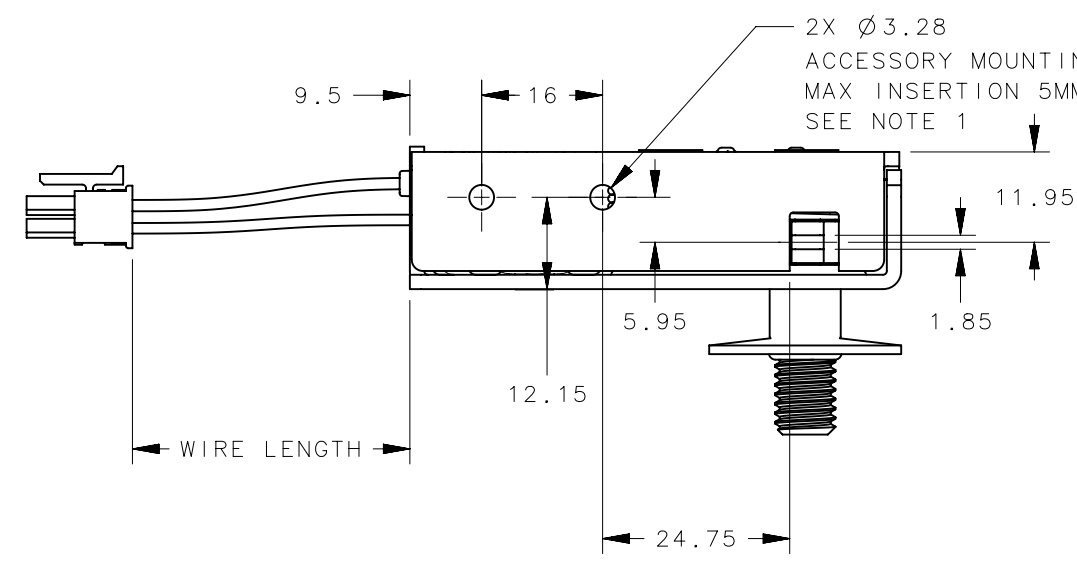
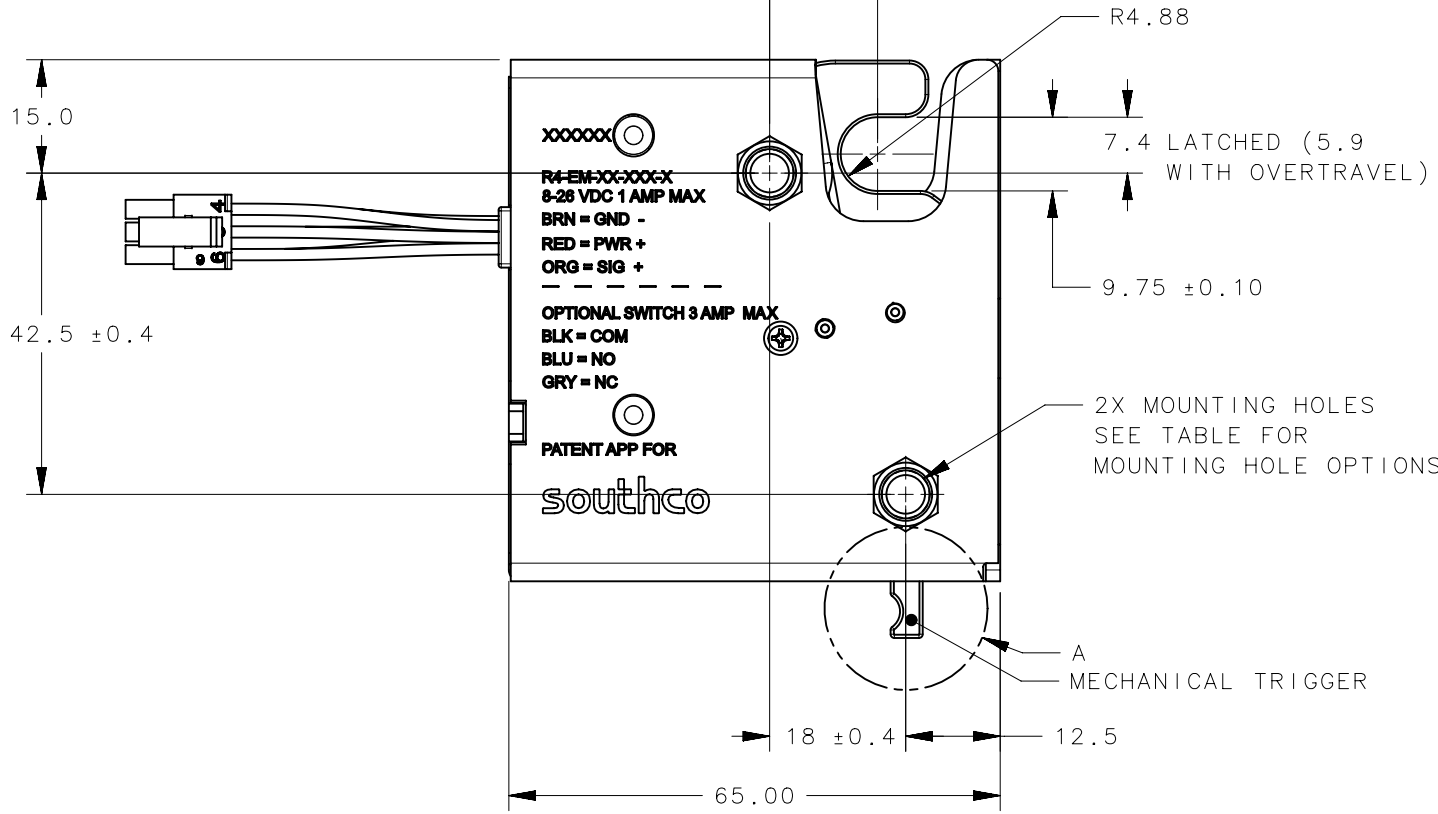

LATCH PART NUMBERS				
ASSEMBLY PART NUMBER	MOUNTING HOLE OPTION	WIRE LENGTH	CONNECTOR	SWITCH
R4-EM-R11-161	1/4-20 UNC THREAD	150MM	YES	YES
R4-EM-R12-161	M6 x 1 THREAD			
R4-EM-R13-161	Ø 7.0 THRU HOLE			
R4-EM-R11-162	1/4-20 UNC THREAD	425MM	NO	
R4-EM-R12-162	M6 x 1 THREAD			
R4-EM-R13-162	Ø 7.0 THRU HOLE			

THIRD ANGLE PROJECTION				
			MILLIMETERS [IN]	
			TOLERANCES UNLESS OTHERWISE NOTED	
ALL DIMENSIONS WITHOUT TOLERANCES ARE FOR REFERENCE ONLY.		DESCRIPTION R4-EM ROTARY, REAR TRIGGER WITH MICROSWITCH		
PROPRIETARY ITEM EXCEPT FOR USES EXPRESSLY GRANTED IN WRITING, INFORMATION DISCLOSED HEREON IS CONFIDENTIAL AND ALL RIGHTS, PATENT AND OTHERWISE, ARE RESERVED BY SOUTHCO, INC.	SIZE B	SYSTEM NX	DWG NO. J-R4-EM-R11-161	
PER ASME Y14.5M-1994	DRAWN BY BGL/CLB	DATE 11NOV2012	SCALE 1:1 SHEET 1 OF 2	

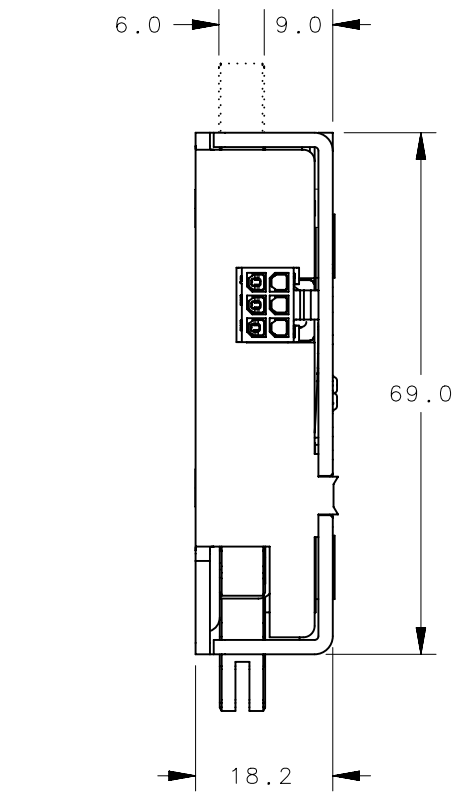

PER ASME Y14.5M-1994

NOTE:

A. MATERIAL AND FINISH:

HOUSING, CAM, TRIGGER AND PINS: STEEL ZINC PLATED
ELECTRONIC ACTUATOR: PLASTIC AND ACETALS AND METAL COMPONENTS.

B. ELECTRICAL SPECIFICATION:

OPERATING VOLTAGE: 8 TO 26 VDC
TYPICAL OPERATING CURRENT: LESS THAN 500 mA AT 12VDC
PEAK/STALL OPERATING CURRENT: 1A MAX AT 12VDC STALL LIMITED TO 1.4 SECONDS
STANDBY CURRENT LESS THAN 185 MICROAMP
CONTROL SIGNAL HIGH (UNLOCK COMMAND): 6 TO 26VDC, 25 mA MAX
CONTROL SIGNAL LOW (LOCK COMMAND): 0 TO 1VDC (OPEN)
LATCH TRANSIT TIME TO RELEASE: 600 MILLISECONDS NO LOAD, 1 SECOND MAX.
OPERATING TEMPERATURE RANGE -20C TO 60C

C. ELECTRICAL CONNECTIONS AND HOOKUP:

A BASIC SWITCH CONTROL ELECTRICAL HOOKUP DIAGRAM IS PROVIDED FOR REFERENCE.
CONSULT WITH A SOUTHCO REPRESENTATIVE FOR ADDITIONAL ELECTRICAL HOOKUP INFORMATION.
-CONNECT POWER, GROUND AND CONTROL SIGNAL WIRES TO AN APPROPRIATE DC POWER SUPPLY.
-A DC POWER SUPPLY CAPABLE OF SUPPLYING 1 AMP MINIMUM IS RECOMMENDED.
-POWER MUST BE AVAILABLE TO OPERATE THE LATCH AND MUST REMAIN AVAILABLE DURING THE FULL TRANSIT TIME OF THE LATCH DURING LOCKING OR UNLOCKING.



CAUTION! LATCH CAN BE DAMAGED IF WIRED INCORRECTLY, OR IF IMPROPER VOLTAGE IS APPLIED!

WIRE COLOR CODE/CONNECTOR PIN ASSIGNMENT

PIN1: BROWN: GROUND (-) PIN4: BLACK: SWITCH COMMON
PIN2: RED: POWER (+12V TYPICAL) PIN5: BLUE: SWITCH N.O. CONTACT
PIN3: ORANGE: CONTROL SIGNAL (+12V TYPICAL) PIN6: GREY: SWITCH N.C. CONTACT

D. ELECTRICAL OPERATION:

TO RELEASE OR TRIGGER THE LATCH : PROVIDE THE FOLLOWING CONTROL SIGNAL TO THE ORANGE WIRE OR CONNECTOR PIN 3
-PROVIDE 6 TO 26VDC (CONTROL SIGNAL HIGH) FOR A MINIMUM OF 50 MILLISECONDS
-THE CONTROL SIGNAL CAN REMAIN HIGH INDEFINITELY BUT MUST BE LOW TO RE-TRIGGER LATCH
ALTERNATE OPERATING MODE: TRIGGER ON POWER UP
-CONNECT CONTROL WIRE (ORANGE) TO POWER WIRE(RED).
-CONNECT POWER AND GROUND, LATCH WILL TRIGGER UPON POWER UP.
-POWER MUST BE AVAILABLE FOR A MINIMUM OF 1 SECOND.
-POWER CAN REMAIN ON INDEFINITELY WITHOUT RE-TRIGGERING.
-POWER MUST BE REMOVED TO RE-TRIGGER LATCH.

E. LATCH CLOSED POSITION FEEDBACK SWITCH:

-NORMALLY OPEN CONTACT (BLUE WIRE) PROVIDES SWITCH CLOSURE WHEN LATCH CAM IS CLOSED
-NORMALLY CLOSED CONTACT (GREY WIRE) PROVIDES SWITCH OPEN WHEN LATCH CAM IS CLOSED
-SWITCH COMMON (BLACK WIRE)
SWITCH RATING: 3A AT 12 VDC MAX



WARNING SWITCH CIRCUIT IS NOT FUSED OR ELECTRICALLY PROTECTED! USE APPROPRIATE EXTERNAL PROTECTION.

WIRE SWITCH CORRECTLY PER ELECTRICAL HOOKUP DIAGRAM AND DO NOT SHORT CIRCUIT. A SHORT CIRCUIT CAN DAMAGE LATCH AND MAY POSE AN ELECTRICAL FIRE HAZARD!

F. OPTIONAL LATCH CONNECTOR:

MANUFACTURER: MOLEX, SERIES MICROFIT 3.0
-CONNECTOR RECEPTICAL 6 POSITION 3MM VERTICAL DUAL: MOLEX P/N: 43025-0600
-CONTACTS: FEMALE CRIMP TERMINAL (SOCKET) MOLEX P/N: 43030-0007
WIRE: 24 AWG STYLE 1007
WIRE LENGTH: SEE TABLE FOR AVAILABLE LENGTHS

G. MATE CONNECTOR (NOT SUPPLIED)

MANUFACTURER: MOLEX, SERIES: MICROFIT 3.0
-CONNECTOR PLUG 6 POSITION 3MM VERTICAL DUAL MOLEX P/N: 43020-0601
-RECOMMENDED CONTACTS (6 REQUIRED): MOLEX, MALE CRIMP TERMINAL (PIN) MOLEX P/N 43031-0007
-RECOMMENDED WIRE GAGE: 24 AWG

H. MOUNTING:

-MOUNT THE LATCH SECURELY USING TWO (2) SCREWS IN THE MOUNTING HOLES PROVIDED (SCREWS NOT PROVIDED)
-MOUNTING HOLES ARE AVAILABLE WITH 1/4-20 UNC THREAD, M6 x 1 THREAD OR Ø7.0 THRU HOLE
-MAXIMUM ALLOWABLE TORQUE ON THREADED MOUNTING SCREWS IS 650 N.cm (57.5 in. lbs)

I. MECHANICAL OPERATION

THE LATCH IS PROVIDED WITH A MECHANICAL TRIGGER TO RELEASE THE LATCH.
THE MAXIMUM TRAVEL OF THE TRIGGER IS SHOWN IN DETAIL A. THE TRIGGER MOVES THROUGH ITS FULL TRAVEL DURING ELECTRICAL OPERATION OF THE LATCH.



CAUTION IT IS IMPORTANT TO NOT OBSTRUCT THE MOTION OF THE TRIGGER DURING ELECTRICAL OPERATION TO PREVENT LONGTERM DAMAGE TO THE ELECTRICAL COMPONENTS IN THE LATCH.

TWO HOLES PROVIDED CAN BE USED TO MOUNT MECHANICAL OVERRIDE LINKAGE RETAINING BRACKETS. STANDARD 1/8" BLIND RIVETS CAN BE USED FOR FASTENING. FOLLOW MAX INSERTION DEPTH INDICATED AND ENSURE THAT NO PARTICLES ENTER THE LATCH. CONTACT SOUTHCO FOR MECHANICAL RELEASE CABLES AND ACTUATORS.
AN OPTIONAL KIT WITH ONE CABLE MOUNTING BRACKET AND TWO RIVETS IS AVAILABLE AS PART NUMBER R4-EM-87 SEE CUSTOMER DRAWING J-R4-EM-87 FOR MORE INFORMATION

J. STRIKER BOLT ASSEMBLY SOLD SEPARATELY

STRIKER BOLT PART NUMBER: R4-90-121-10, REFER TO CUSTOMER DRAWING J-R4-90-121 FOR ADDITIONAL INFORMATION

K. PACKAGED IN INDIVIDUAL BOXES OR ADD -1 TO PART NUMBER FOR BULK PACKAGING

EXAMPLE: R4-EM-R11-161
R4-EM-R11-161-1

REVISION HISTORY			
REV	DATE	BY	DESCRIPTION
B	25SEP2013	DJK/WJB	PRN: P2013-1922

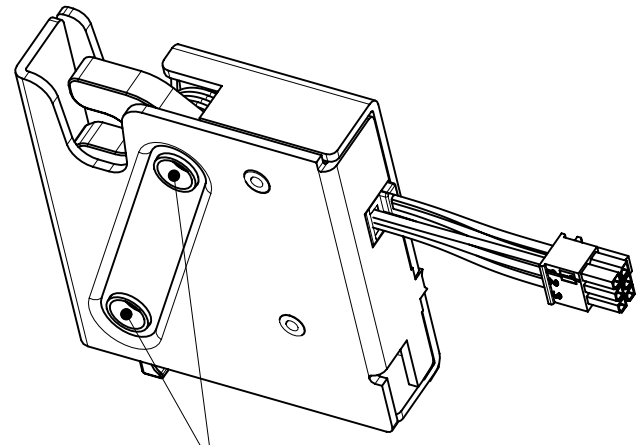

NOTE: MOUNTING HOLES ARE RECESSED 1.3 MM ON THIS SIDE

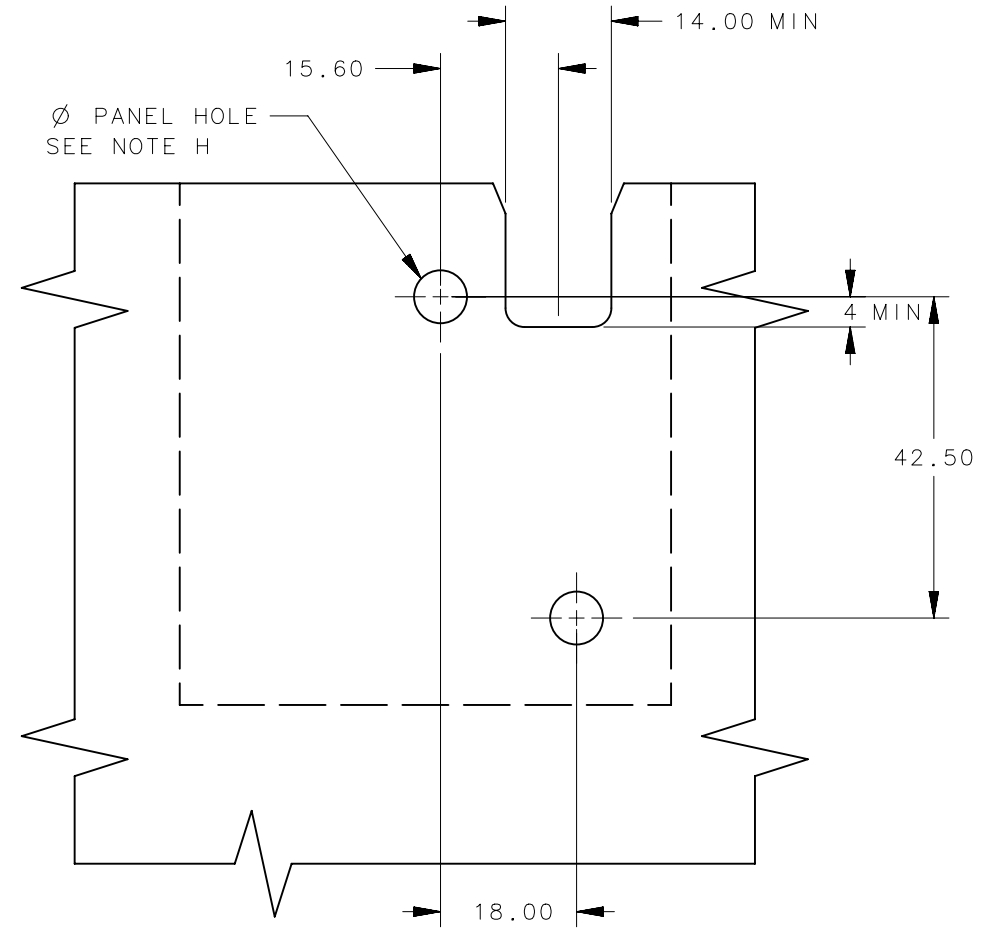
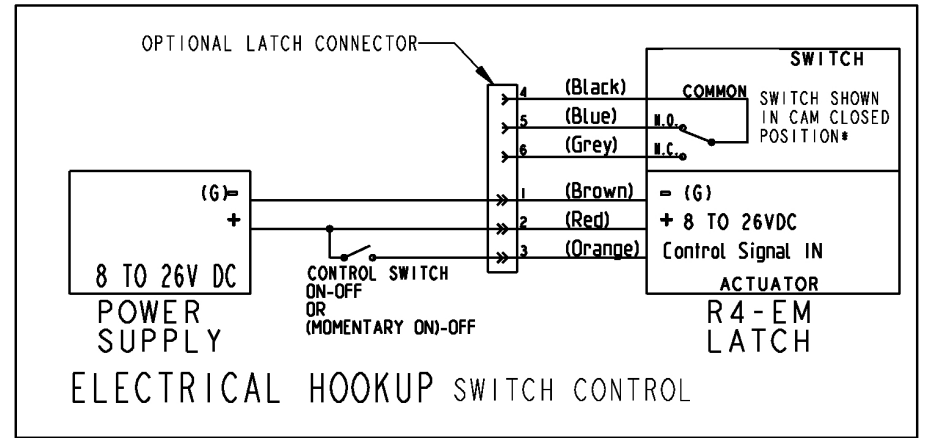

THIRD ANGLE PROJECTION		southco CONNECT • CREATE • INNOVATE	
MILLIMETERS [IN]			
TOLERANCES UNLESS OTHERWISE NOTED		DESCRIPTION R4-EM ROTARY, REAR TRIGGER, WITH MICROSWITCH	
ALL DIMENSIONS WITHOUT TOLERANCES ARE FOR REFERENCE ONLY.		SIZE B	SYSTEM NX
PER ASME Y14.5M-1994		DWG NO. J-R4-EM-R11-161	SCALE 1:1
PROPRIETARY ITEM <small>EXCEPT FOR USES EXPRESSLY GRANTED IN WRITING, INFORMATION DISCLOSED HEREON IS CONFIDENTIAL AND ALL RIGHTS, PATENT AND OTHERWISE, ARE RESERVED BY SOUTHCO, INC.</small>		DATE 11NOV2012	SHEET 2 OF 2